



**Speed Queen<sup>®</sup>**

**Parts and  
Service Manual  
for  
Commercial  
Automatic Washers  
(SA Models)  
(Metered and Nonmetered)**

## WARNING

**FAILURE TO INSTALL, MAINTAIN AND/OR OPERATE THIS MACHINE ACCORDING TO THE MANUFACTURER'S INSTRUCTIONS MAY RESULT IN CONDITIONS WHICH CAN PRODUCE BODILY INJURY AND/OR PROPERTY DAMAGE.**

**NOTE:** The WARNING and IMPORTANT instructions appearing in this manual are not meant to cover all possible conditions and situations that may occur. It must be understood that common sense, caution and carefulness are factors which CANNOT be built into these washers. These factors MUST BE supplied by the person(s) installing, maintaining or operating the washer.

Always contact the dealer, distributor, service agent or the manufacturer about any problems or conditions you do not understand.

### INFORMATION CONTAINED IN THIS MANUAL IS APPLICABLE TO THESE WASHERS

Model Numbers	Metered Models	Non-Metered Models	One Speed Motor	Two Speed Motor	Porcelain Washtub	Stainless Steel Washtub
SA4710 and SA4714		X	X		X	
SA4711 and SA4715		X	X			X
SA4720 and SA4724		X		X	X	
SA4721 and SA4725		X		X		X
SA4950, SA4954, SA4960 SA4962 and SA4964	X		X		X	
SA4951, SA4955, SA4961 SA4963 and SA4965	X		X			X
SA4970, SA4974, SA4980 SA4982 and SA4984	X			X	X	
SA4971, SA4975, SA4981 SA4983 and SA4985	X			X		X

## Nameplate Location

### IMPORTANT

When writing for information on any washer, be sure to mention model and serial numbers. The model and serial numbers will be found on the nameplate as shown.

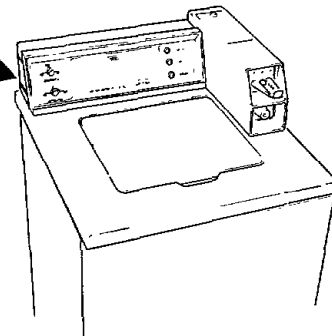

Any reuse or reproduction of the artwork and copy appearing in this manual is strictly prohibited without the written consent of the Speed Queen Company, Ripon, WI 54971-0070.

# Table of Contents

## SECTION I PARTS

Control Panel, Control Hood and Controls .....	3
Kingston Timer, Case and Plate .....	4
Mallory Timer, Case and Plate .....	5
Kingston Timer, Meter Case and Service Door ..	6
Mallory Timer, Meter Case and Service Door ..	7
Cabinet Top and Loading Door .....	8
Switch and Bracket Assembly .....	9
Inlet Hose, Filler Hose, Backflow Preventer and Mixing Valve Mounting Bracket .....	10,11
Mixing Valve Assembly .....	12
Agitator and Post .....	13
Clothes Guard, Washtub and Hub .....	14
Lint Filter, Washtub and Hub .....	15
Outer Tub, Cover and Pressure Hose .....	16,17
Motor, Mounting Bracket, Belts and Idler Assembly .....	18,19
Transmission Assembly and Balance Ring .....	20
Bearing Housing, Brake, Pulley and Pivot Dome Pump Assembly, Bracket, Hoses and Siphon Break Kit .....	22
Front Panel, Cabinet and Base .....	23
Power Cord, Wire and Terminals .....	25
	26

## SECTION II SERVICE PROCEDURES

1. Control Panel .....	27
2. Speed or Wash Temperature Switch .....	27
3. Indicator Lights (Wash, Rinse, Spin or Unbalanced Load) .....	27
4. Timer Assembly - Metered Models .....	28
5. Timer Assembly - Nonmetered Models .....	28
6. Meter Case .....	29
7. Timer Case .....	29
8. Pressure Switch .....	30
9. Drain Hose Elbow .....	30
10. Loading Door .....	30
11. Agitator Post Assembly .....	30
12. Agitator Drive Shaft .....	31
13. Front Panel .....	32
14. Pump Belt .....	32
15. Drive Belt .....	32
16. Motor and Mounting Bracket .....	34
17. Idler Lever and Pulley .....	37
18. Motor Drive Pulley or Pump Pulley .....	37
19. Motor Switch .....	37
20. Pump Assembly .....	38
21. Cabinet Top Assembly .....	38

22. Door and Out-of-Balance Switch and Bracket Assembly .....	40
23. Mixing Valve Assembly .....	41
24. Washtub and Clothes Guard or Lint Filter ..	42
25. Water Seal Assembly .....	42
26. Outer Tub .....	45
27. Drive Pulley and Helix .....	47
28. Brake Assembly .....	47
29. Lower Bearing Housing .....	47
30. Transmission Assembly .....	49
31. Balance Ring .....	51
32. Upper Bearing Assembly .....	51

## SECTION III ADJUSTMENTS

33. Leveling Legs .....	52
34. Pressure Switch .....	52
35. Belt - Agitate and Spin .....	53
36. Belt - Pump .....	53
37. Out-of-Balance Switch Trigger .....	53

## SECTION IV SERVICE HELPS

38. No Hot Water .....	54
39. No Cold Water .....	54
40. No Warm Water .....	55
41. Water Fill Does Not Stop at Proper Level ..	55
42. Timer Does Not Advance .....	55
43. No Agitation .....	56
44. Constant Agitation .....	56
45. Low Spin or No Spin .....	56
46. Constant Spin .....	57
47. Drive Motor Overload Protector Cycles Repeatedly .....	57
48. Outer Tub Does Not Empty .....	57
49. Excessive Vibration .....	57
50. Water Leaking From Outer Tub .....	58
Special Tools .....	59

## SECTION V TEST PROCEDURES

Motor Start Windings .....	60
Motor High and Low Windings .....	61

## SECTION VI CYCLE SEQUENCE CHARTS .. 62-65

## SECTION VII CIRCUITRY SCHEMATICS ... 66-76

## SECTION VIII WIRING DIAGRAMS ..... 77-80

# SECTION I

## Parts

\*ADD SUFFIX LETTER TO PART NUMBER TO DESIGNATE COLOR.  
**D** Apple Green      **H** Harvest Gold  
**L** Almond            **W** White

**CONTROL PANEL**  
 Models SA4710, SA4711, SA4714, SA4715, SA4950, SA4951, SA4954, SA4955, SA4960, SA4961, SA4962, SA4963, SA4964 and SA4965..... 27645  
 Models SA4720, SA4721, SA4924, SA4925, SA4970, SA4971, SA4974, SA4975, SA4980, SA4981, SA4982, SA4983, SA4984 and SA4985..... 27646

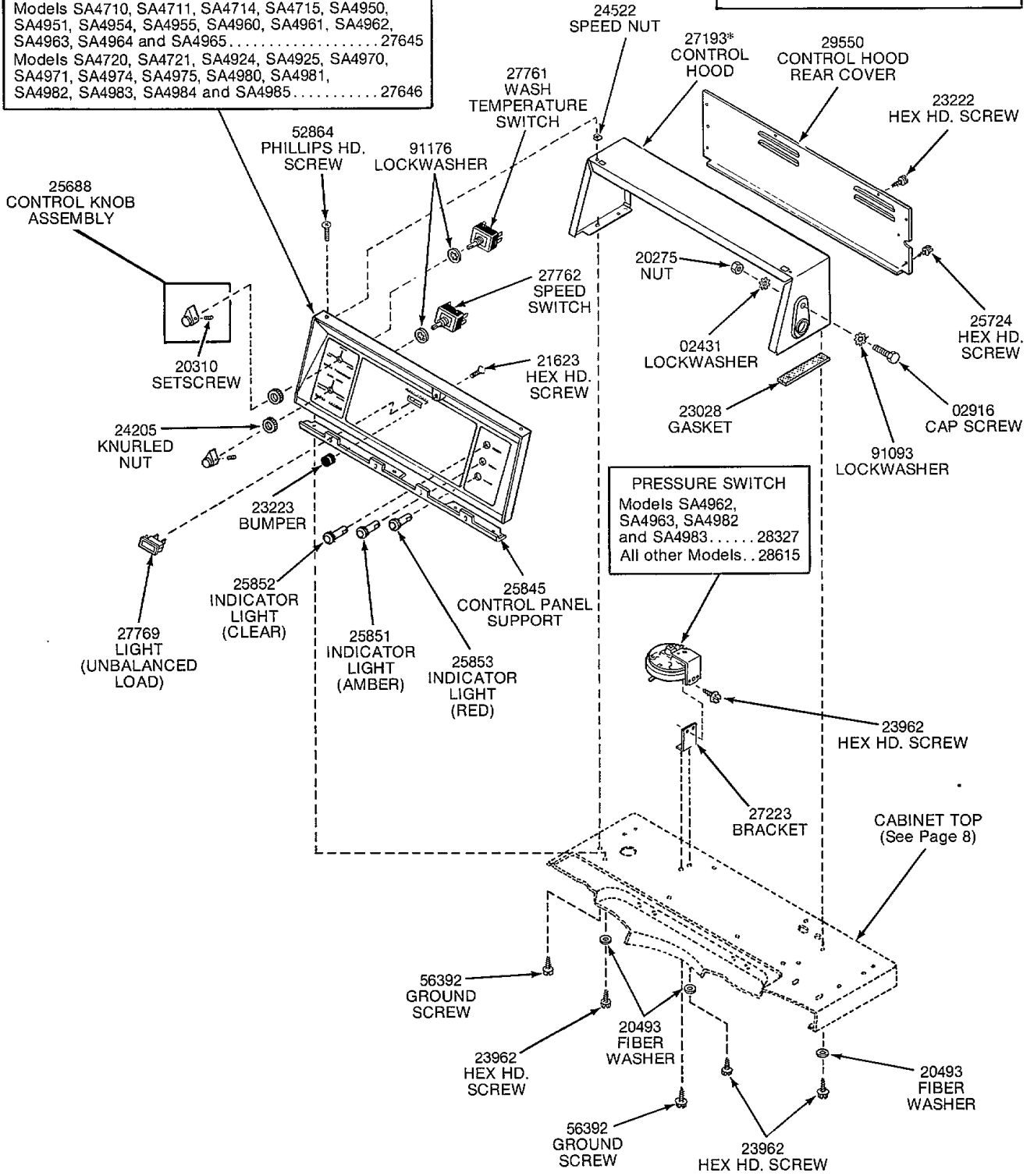

**CONTROL PANEL, CONTROL HOOD AND CONTROLS**

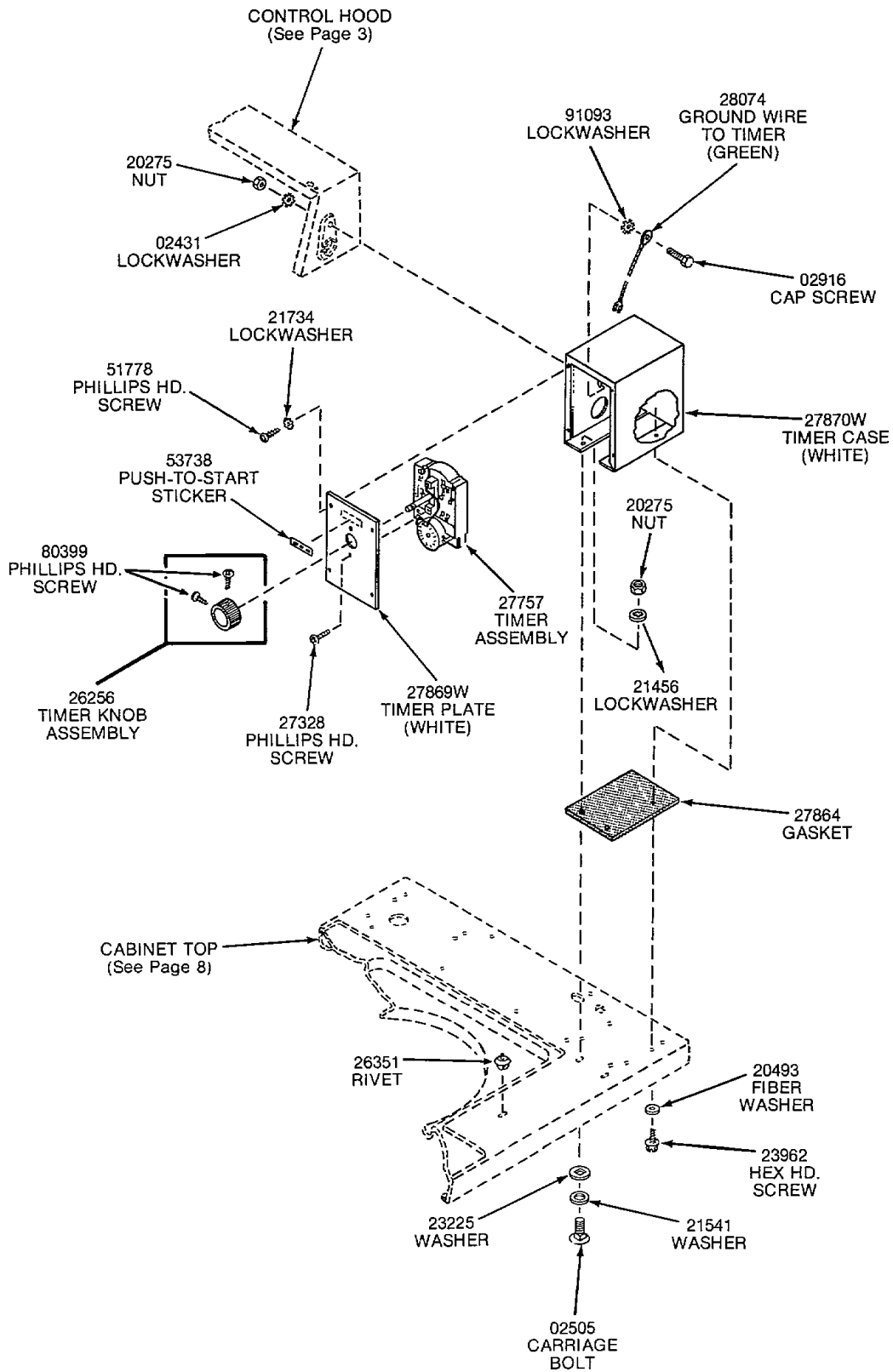

**KINGSTON TIMER, CASE AND PLATE**  
 (Models SA4710, SA4711, SA4714, SA4715, SA4720, SA4721, SA4724 and SA4725)

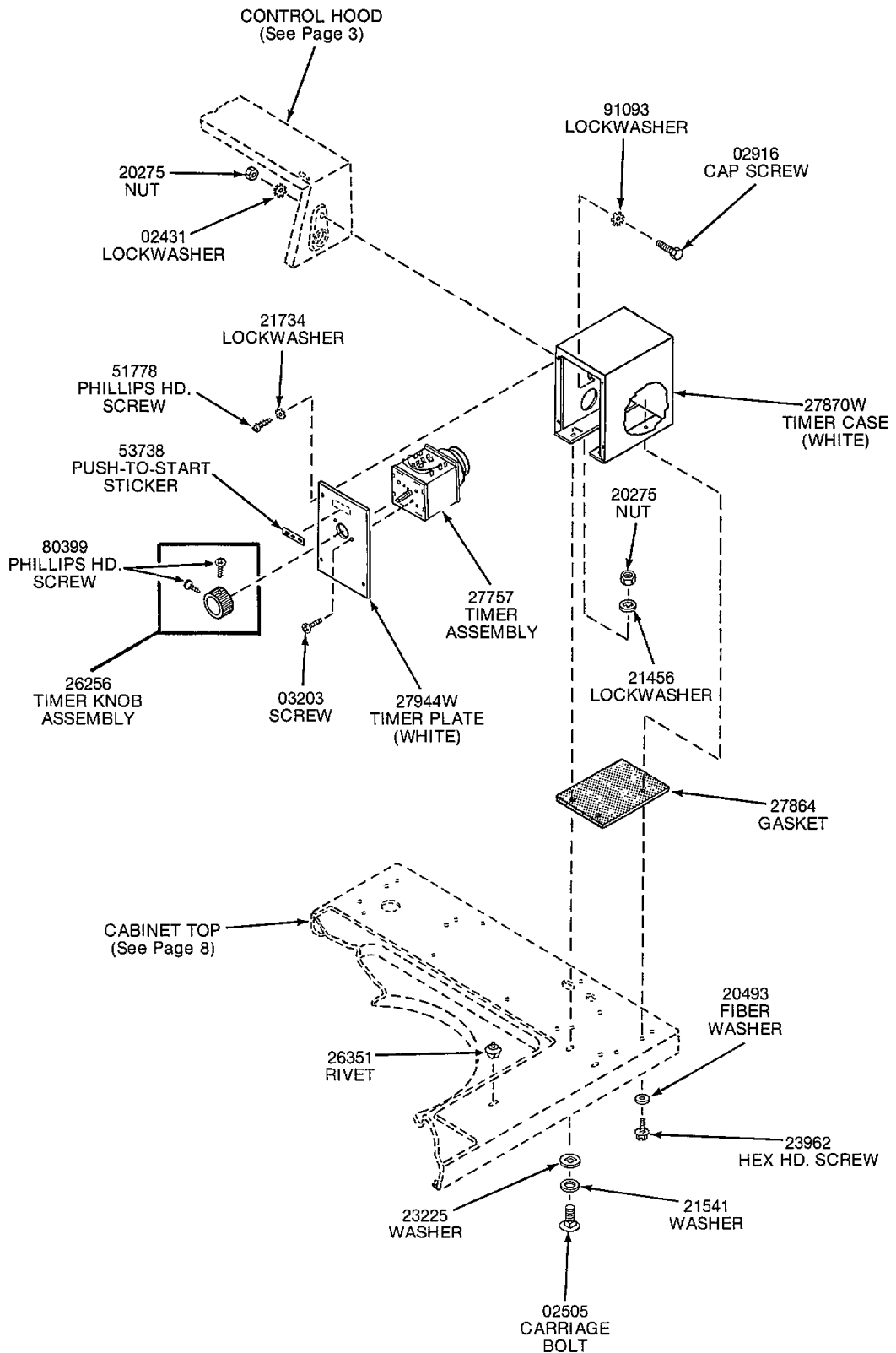

**MALLERY TIMER, CASE AND PLATE**  
 (Models SA4710, SA4711, SA4714, SA4715, SA4720, SA4721, SA4724 and SA4725)

\*ADD SUFFIX LETTER TO PART NUMBER TO DESIGNATE COLOR.  
**D** Apple Green    **H** Harvest Gold  
**L** Almond        **W** White

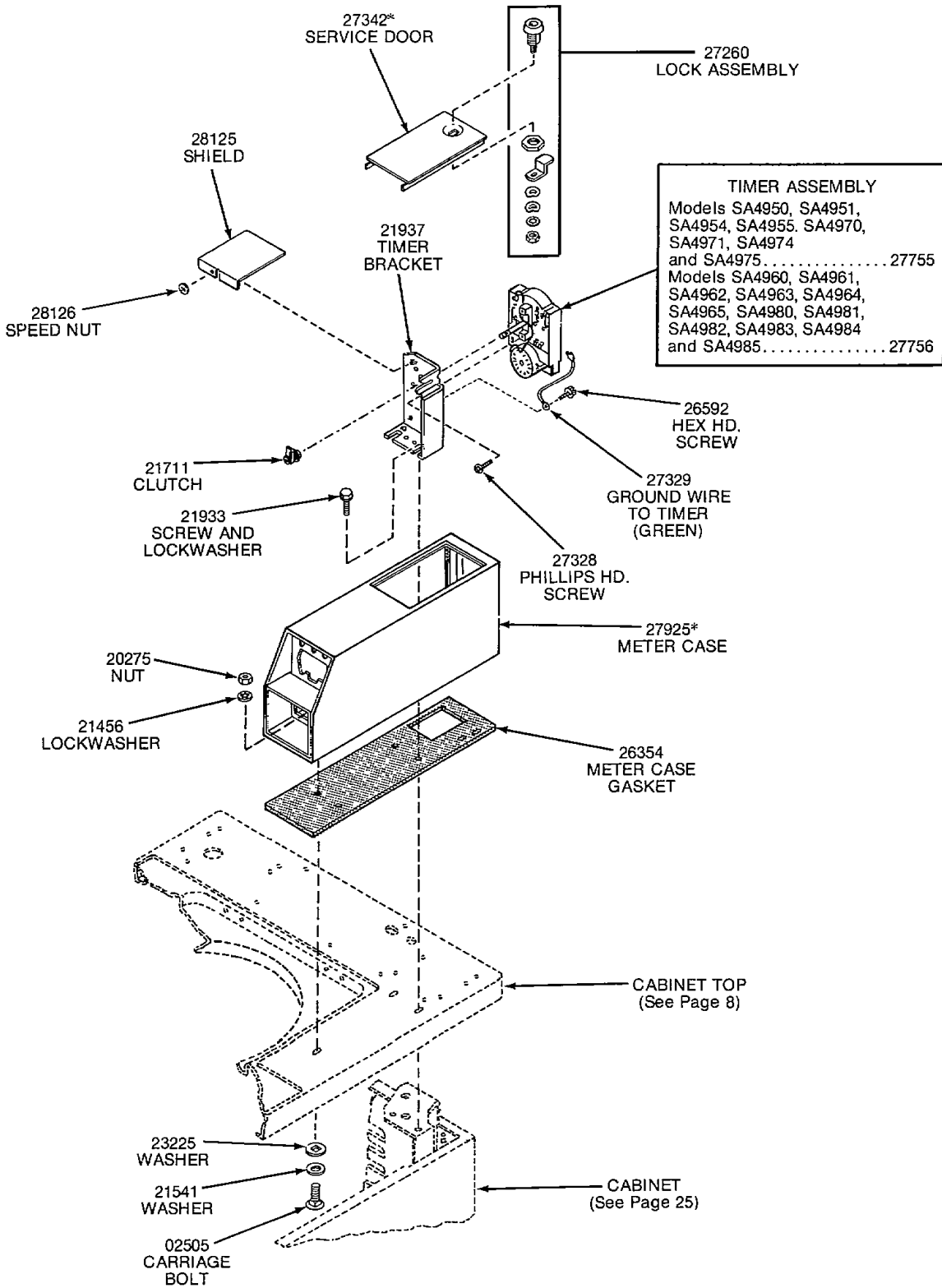

**KINGSTON TIMER, METER CASE AND SERVICE DOOR**

\*ADD SUFFIX LETTER TO PART NUMBER TO DESIGNATE COLOR.  
**D** Apple Green      **H** Harvest Gold  
**L** Almond              **W** White

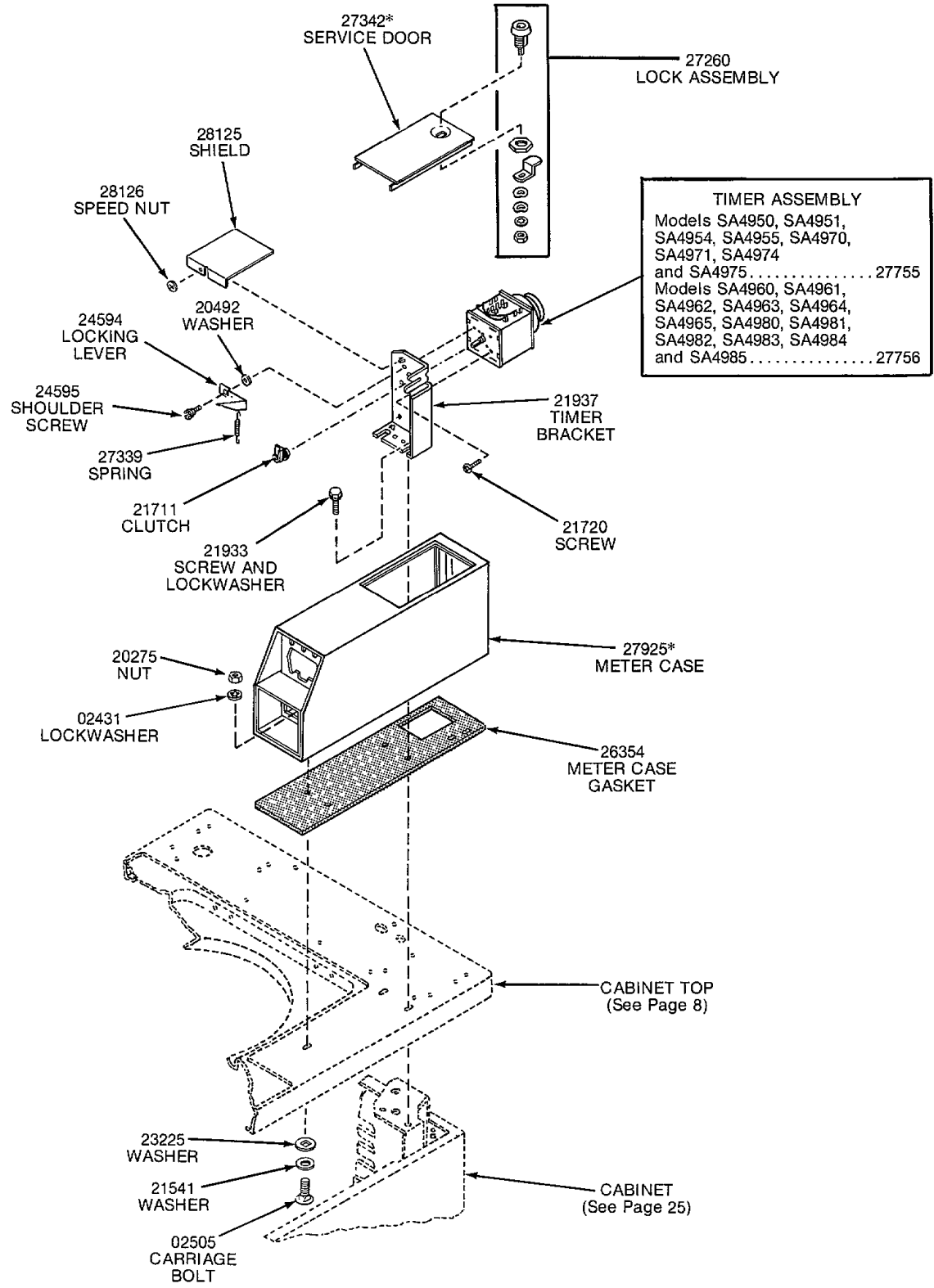

**MALLORY TIMER, METER CASE AND SERVICE DOOR**



\*ADD SUFFIX LETTER TO PART NUMBER TO DESIGNATE COLOR.

**D** Apple Green      **H** Harvest Gold  
**L** Almond            **W** White

**LOADING DOOR**

Models SA4950, SA4951, SA4954,  
 SA4955, SA4960, SA4961, SA4962,  
 SA4963, SA4964 and SA4965 .....27737\*  
 Models SA4970, SA4971, SA4974,  
 SA4975, SA4980, SA4981, SA4982,  
 SA4983, SA4984 and SA4985 .....27738\*  
 Models SA4710, SA4711,  
 SA4714 and SA4715 .....27739\*  
 Models SA4720, SA4721,  
 SA4724 and SA4725 .....27740\*

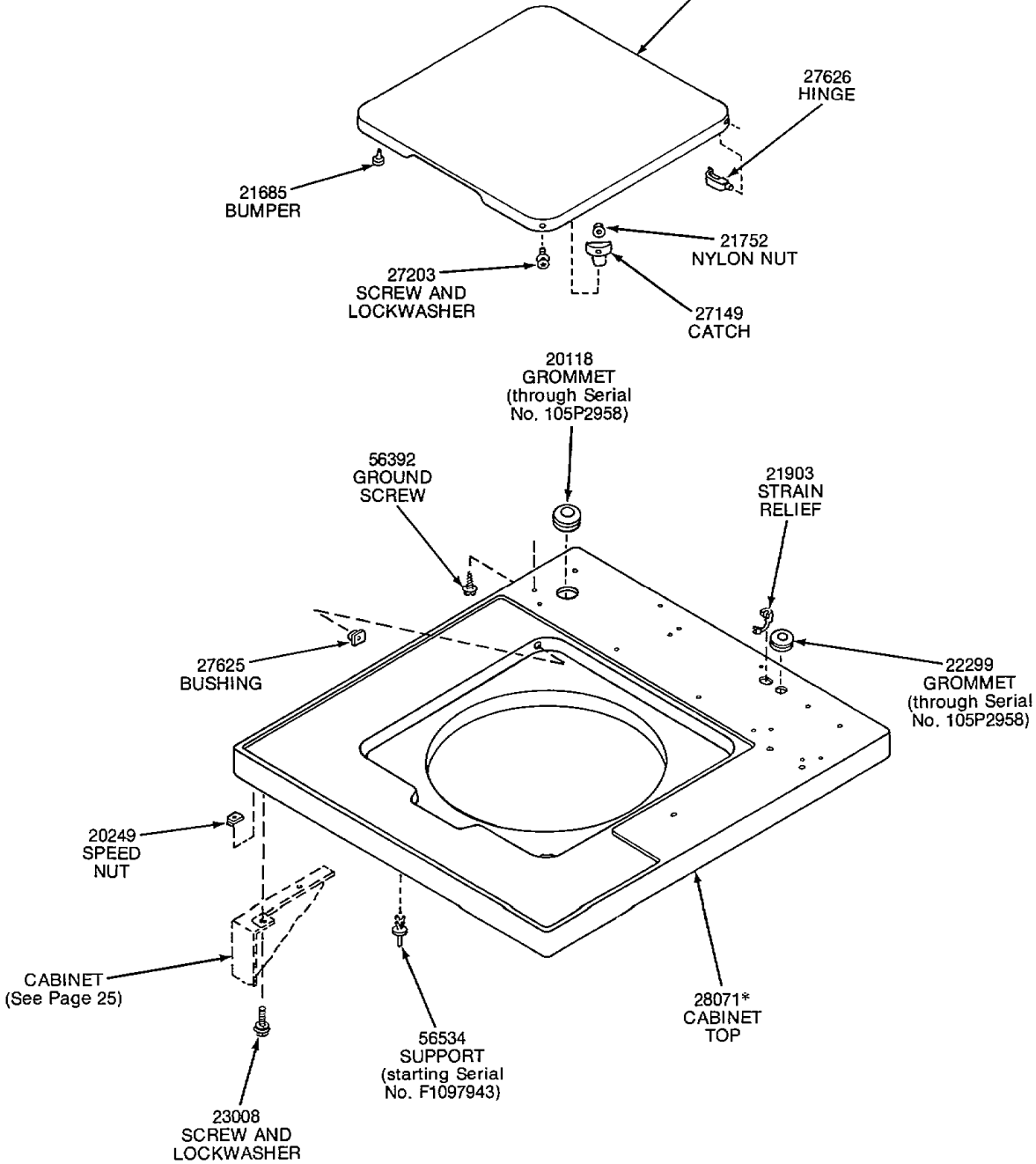

**CABINET TOP AND LOADING DOOR**

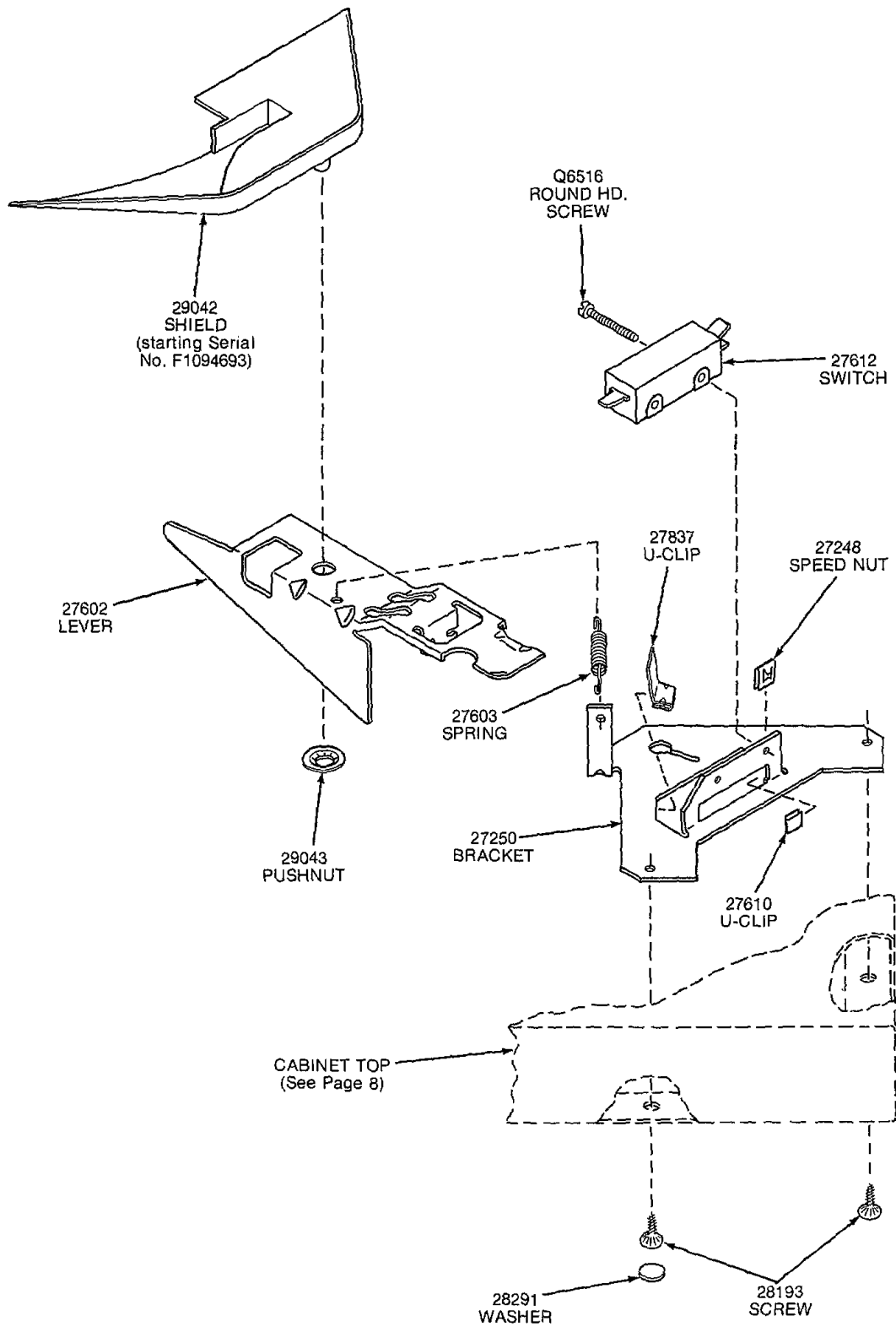

**SWITCH AND BRACKET ASSEMBLY**

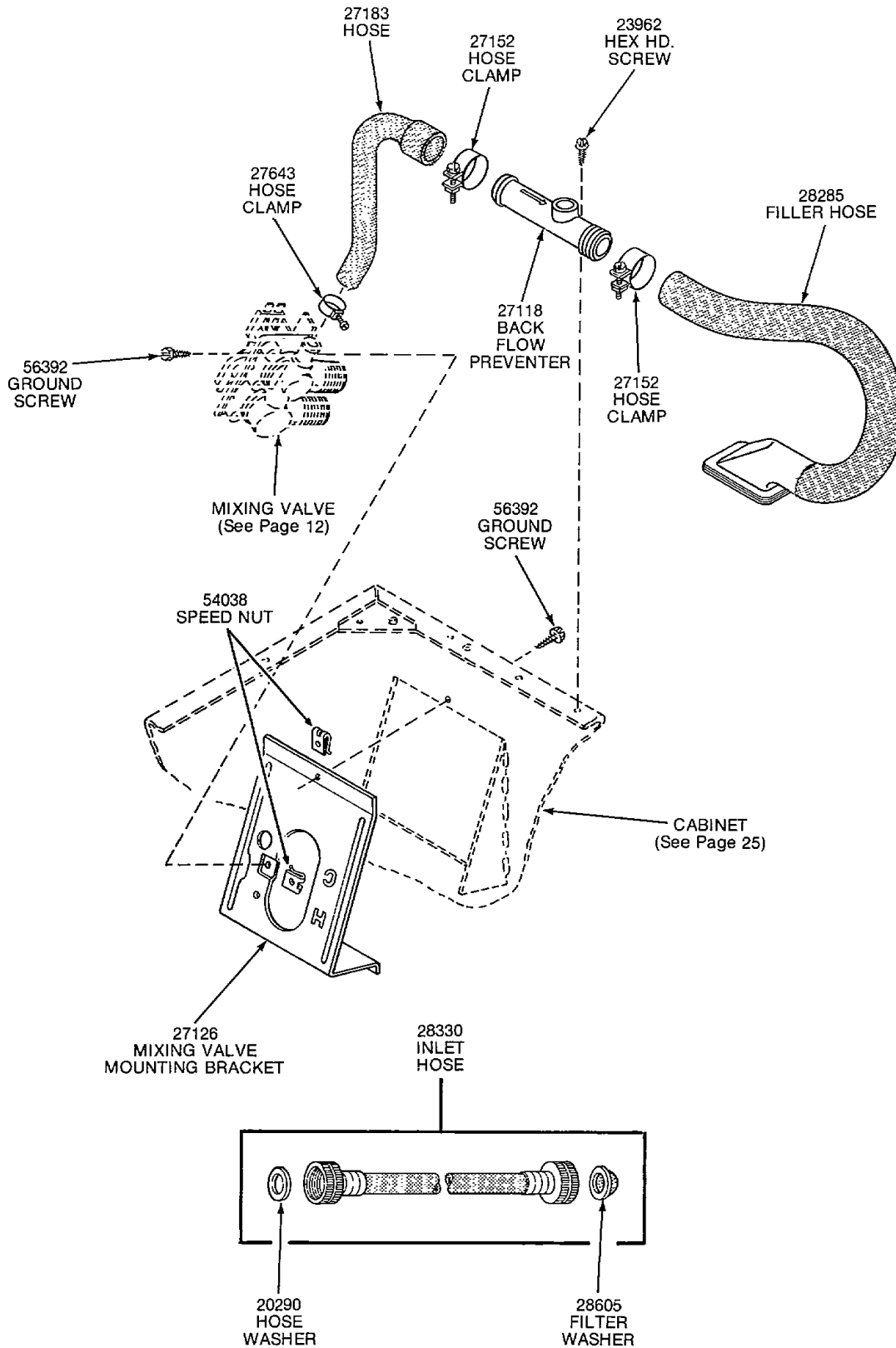

**INLET HOSE, FILLER HOSE, BACK FLOW PREVENTER  
 AND MIXING VALVE MOUNTING BRACKET  
 (through Serial No. N1157099)**

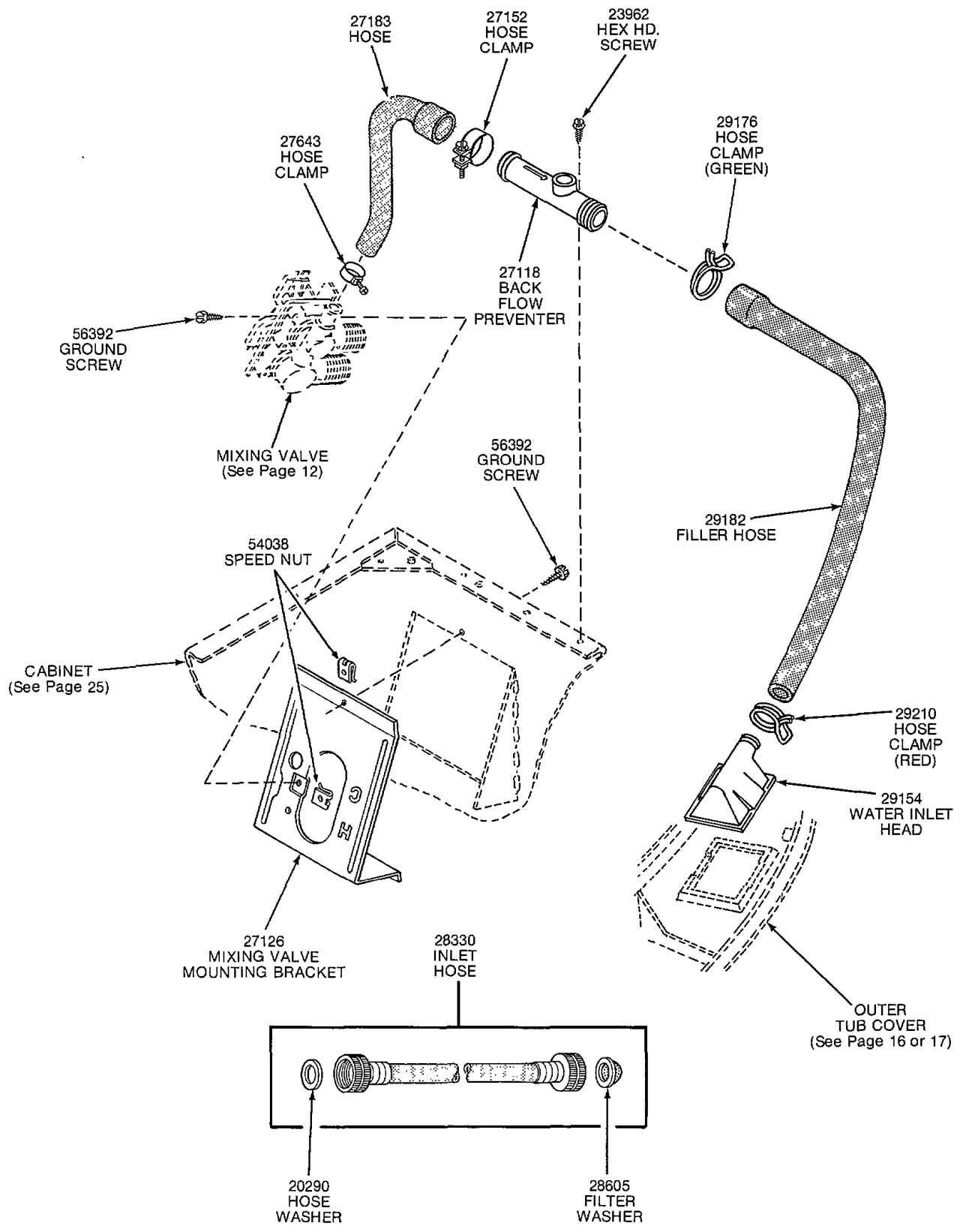

**INLET HOSE, FILLER HOSE, BACK FLOW PREVENTER  
AND MIXING VALVE MOUNTING BRACKET  
(starting Serial No. N1157100)**

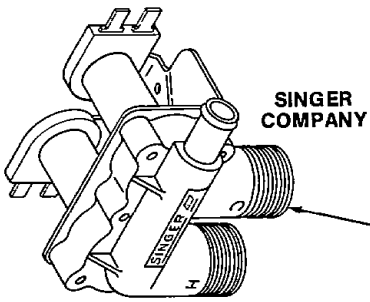

27156  
MIXING VALVE  
ASSEMBLY

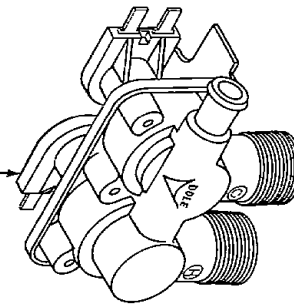

NOTE: Component parts  
for the Singer Company valve  
are no longer available.

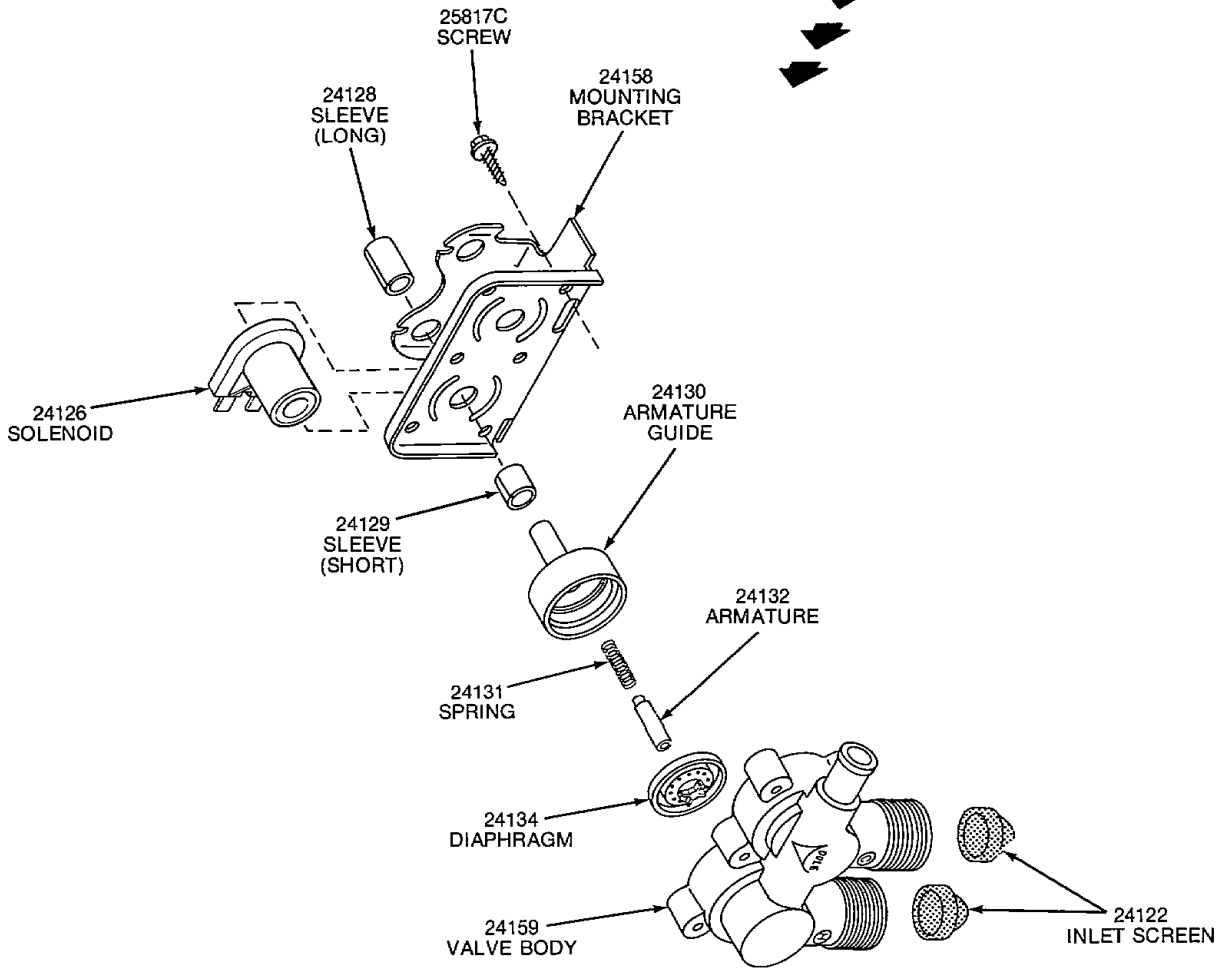
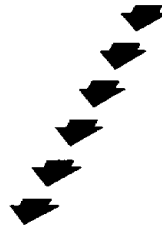

**MIXING VALVE ASSEMBLY**

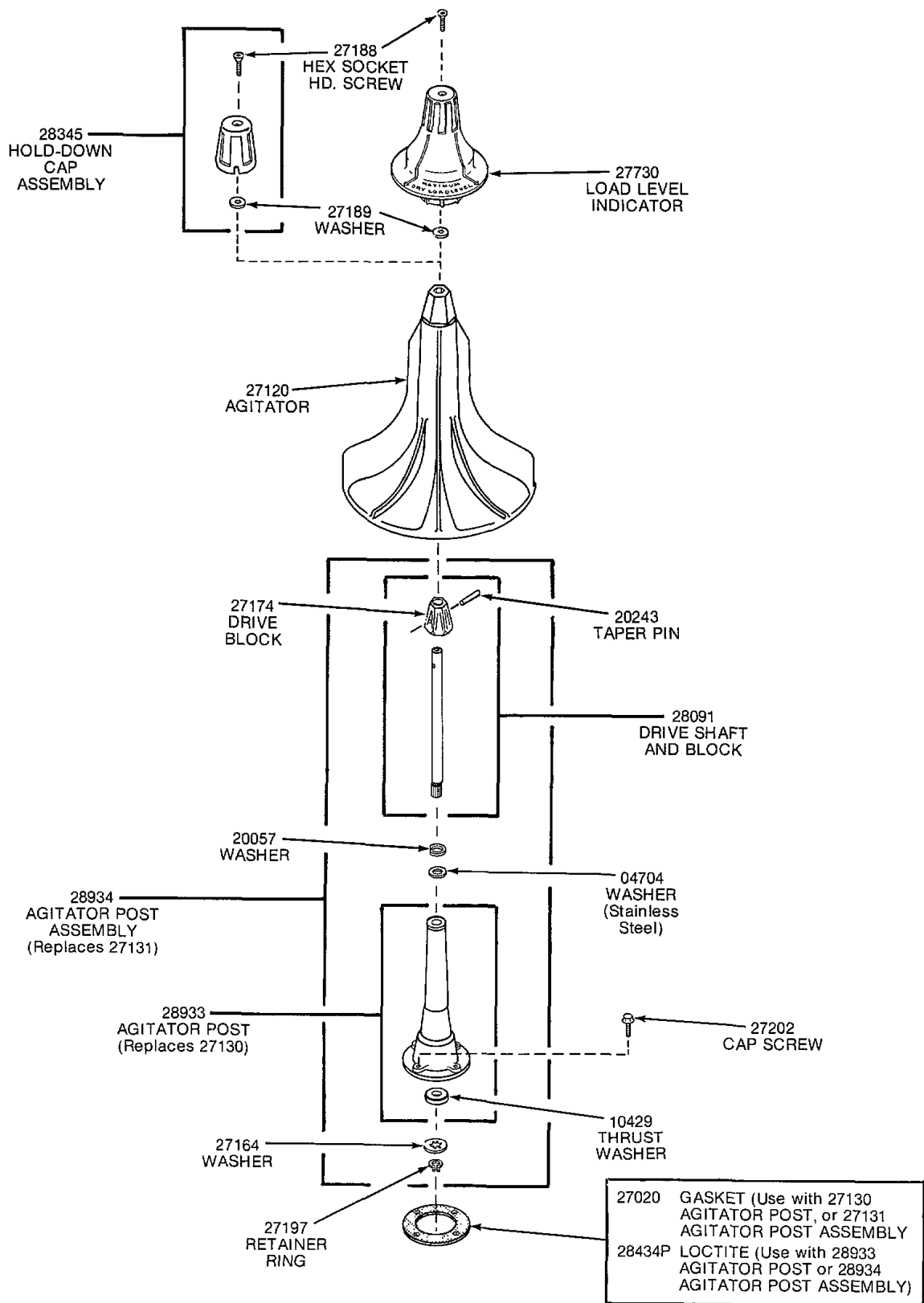

**AGITATOR AND POST**

**381P3 COLLAR KIT**

Includes:

- 1 - 27184 Gasket
- 1 - 28345 Hold-Down Cap
- 1 - 29071 Load Level Collar (starting Serial No. F1099507)
- 8 - 29474 Fasteners

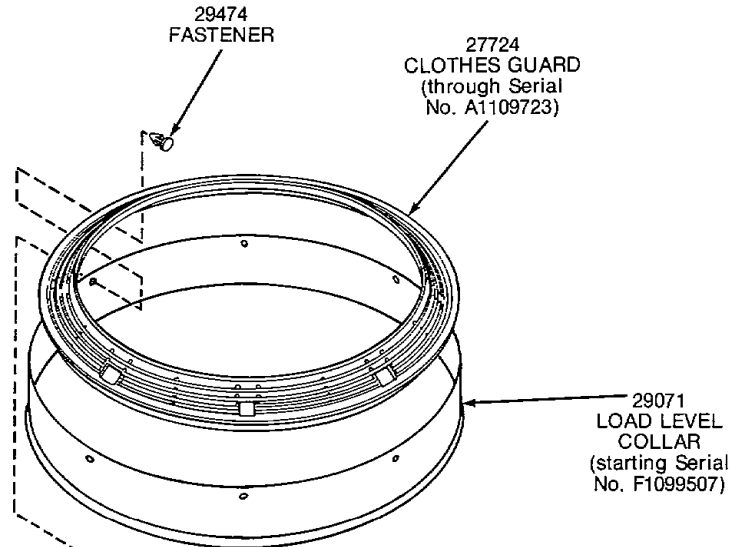

**WASHTUB**  
(through Serial No. F1094692)

- Porcelain ..... 28286
- Stainless Steel ..... 27074

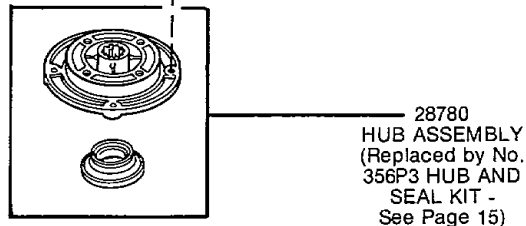
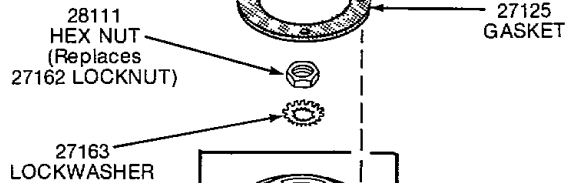
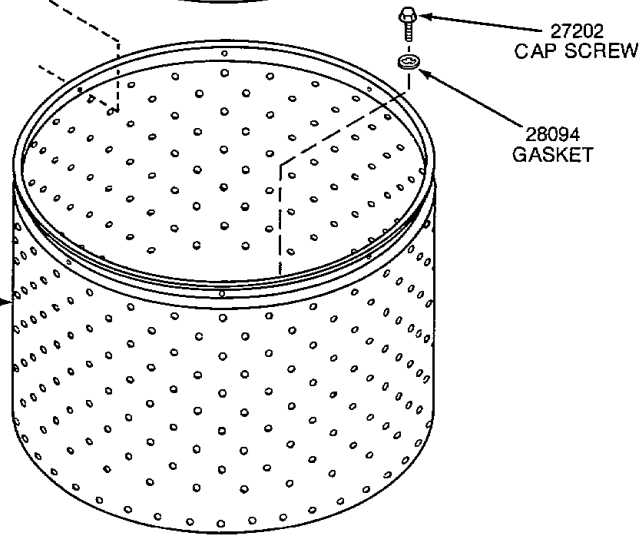

**CLOTHES GUARD, WASHTUB AND HUB**

**381P3 COLLAR KIT**  
 Includes:  
 1 - 27184 Gasket  
 1 - 28345 Hold-Down Cap  
 1 - 29071 Load Level Collar  
 8 - 29474 Fasteners

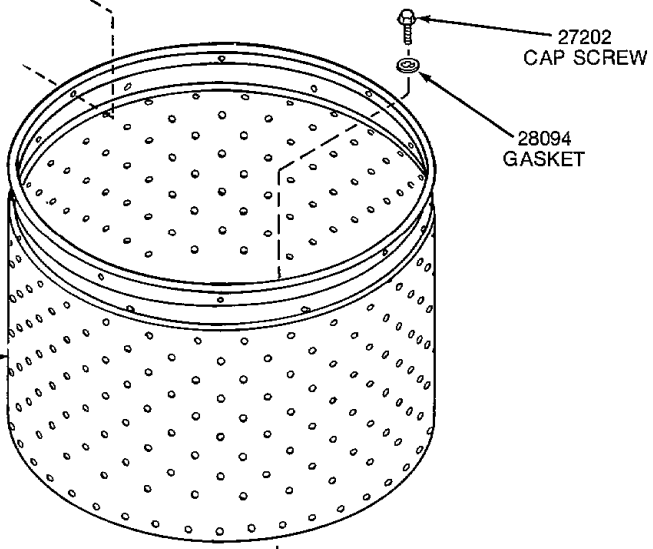
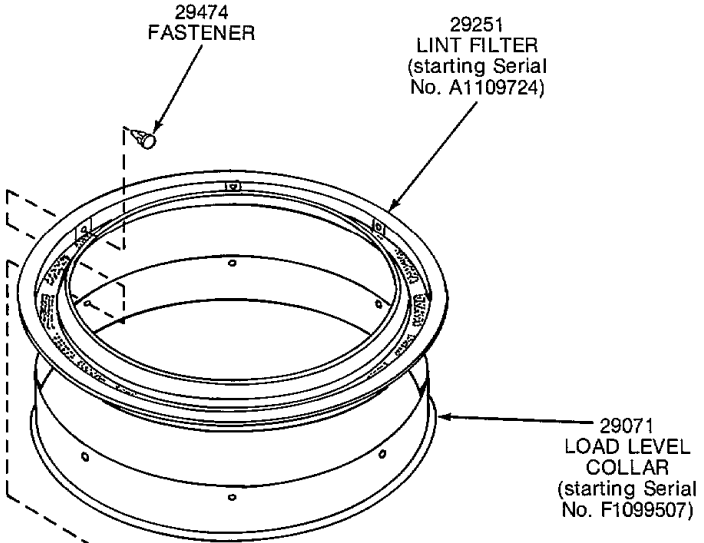

**WASHTUB**  
 (starting Serial No. F1094693)  
 Porcelain..... 29074  
 Stainless Steel..... 28138

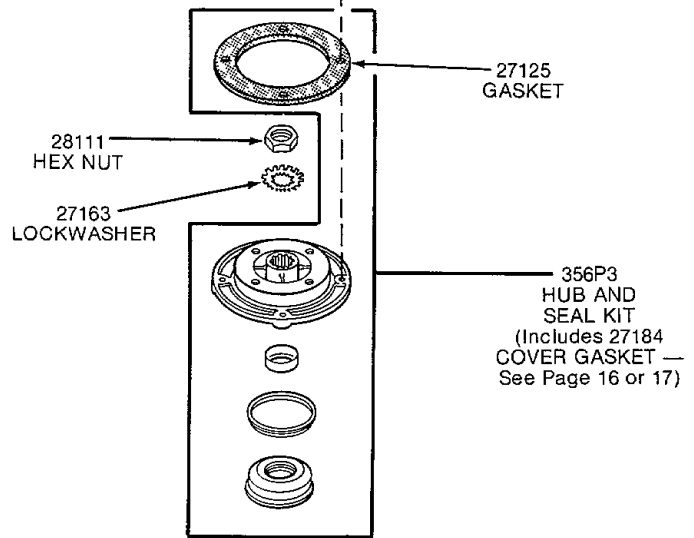

**LINT FILTER, WASHTUB AND HUB**



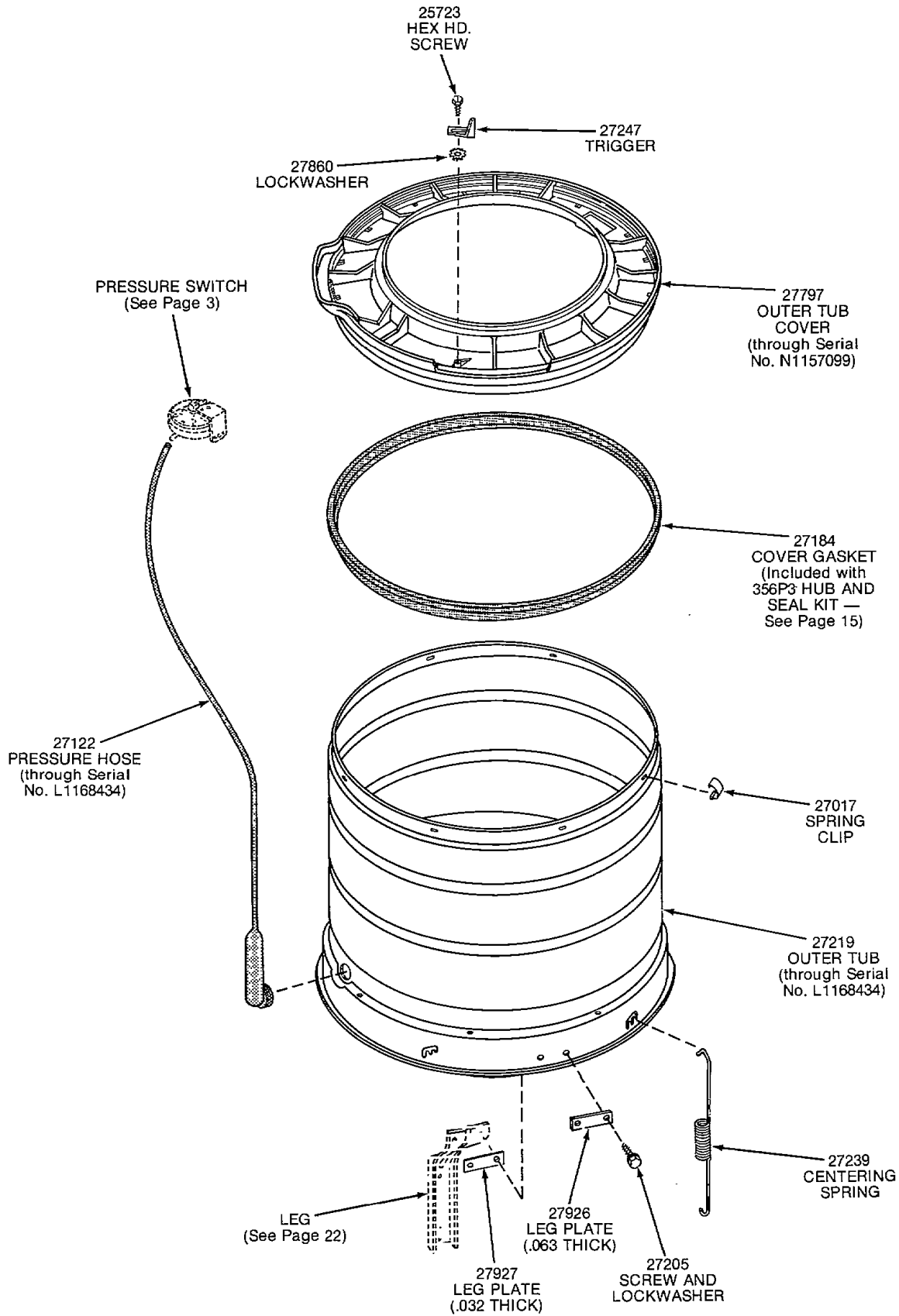

**OUTER TUB, COVER AND PRESSURE HOSE**

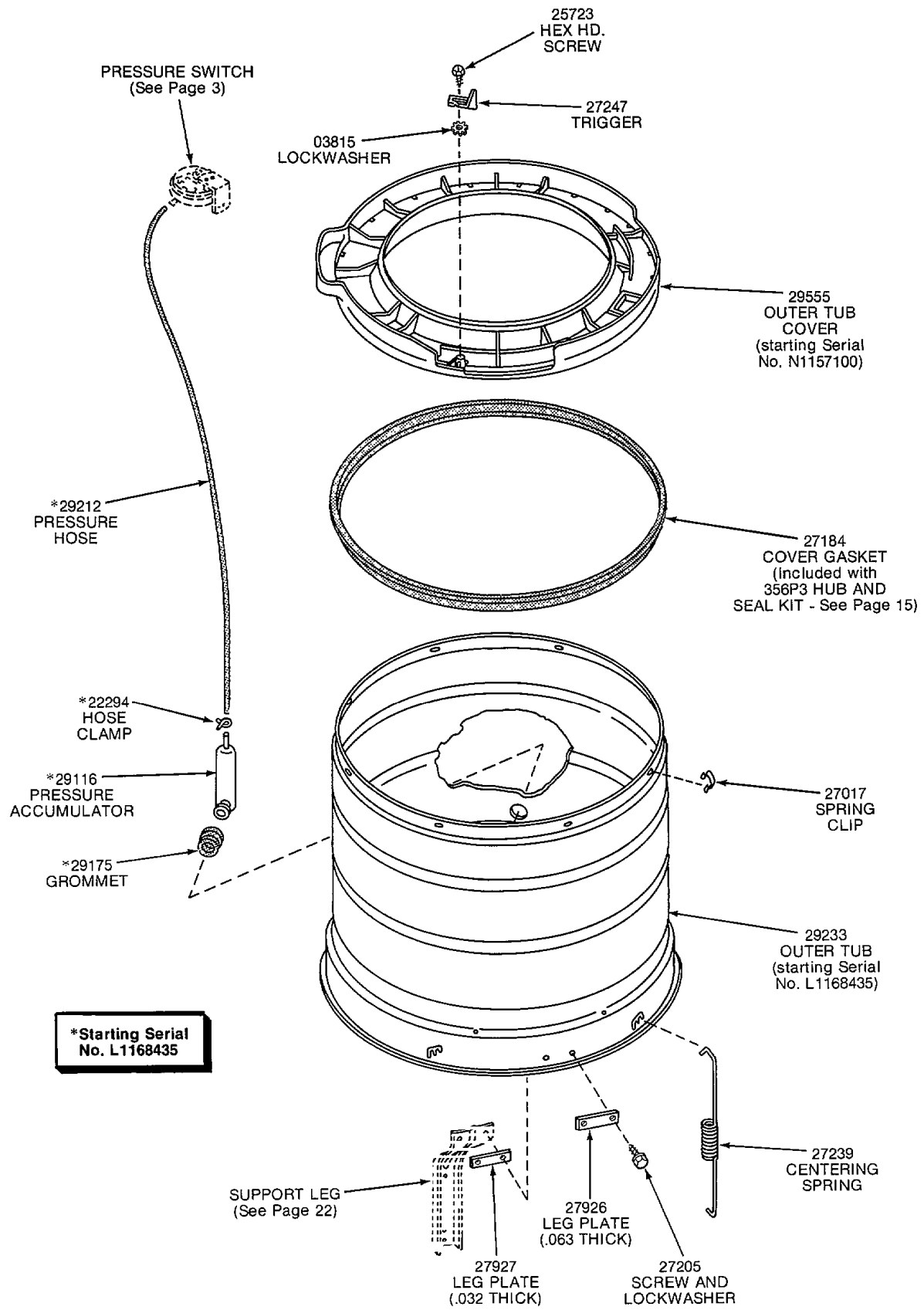

**\*Starting Serial  
No. L1168435**

**OUTER TUB, COVER AND PRESSURE HOSE**



**258P3 CAPACITOR KIT**  
(For use in areas where low voltage exists.)

**MOTOR SWITCH**  
24139 (for Emerson Motor No. 27179)  
24140 (for Emerson Motor No. 27658)  
24142 (for General Electric Motor No. 27179)  
24149 (for General Electric Motor No. 27658)

**MOTOR**  
(120 Volt, 60 Hertz, 1 Phase)  
Models SA4710, SA4711, SA4714, SA4715, SA4950, SA4951, SA4954, SA4955, SA4960, SA4961, SA4962, SA4963, SA4964 and SA4965 ..... 27658 (1 Speed)  
Models SA4720, SA4721, SA4724, SA4725, SA4970, SA4971, SA4974, SA4975, SA4980, SA4981, SA4982, SA4983, SA4984 and SA4985 ..... 27179 (2 Speed)

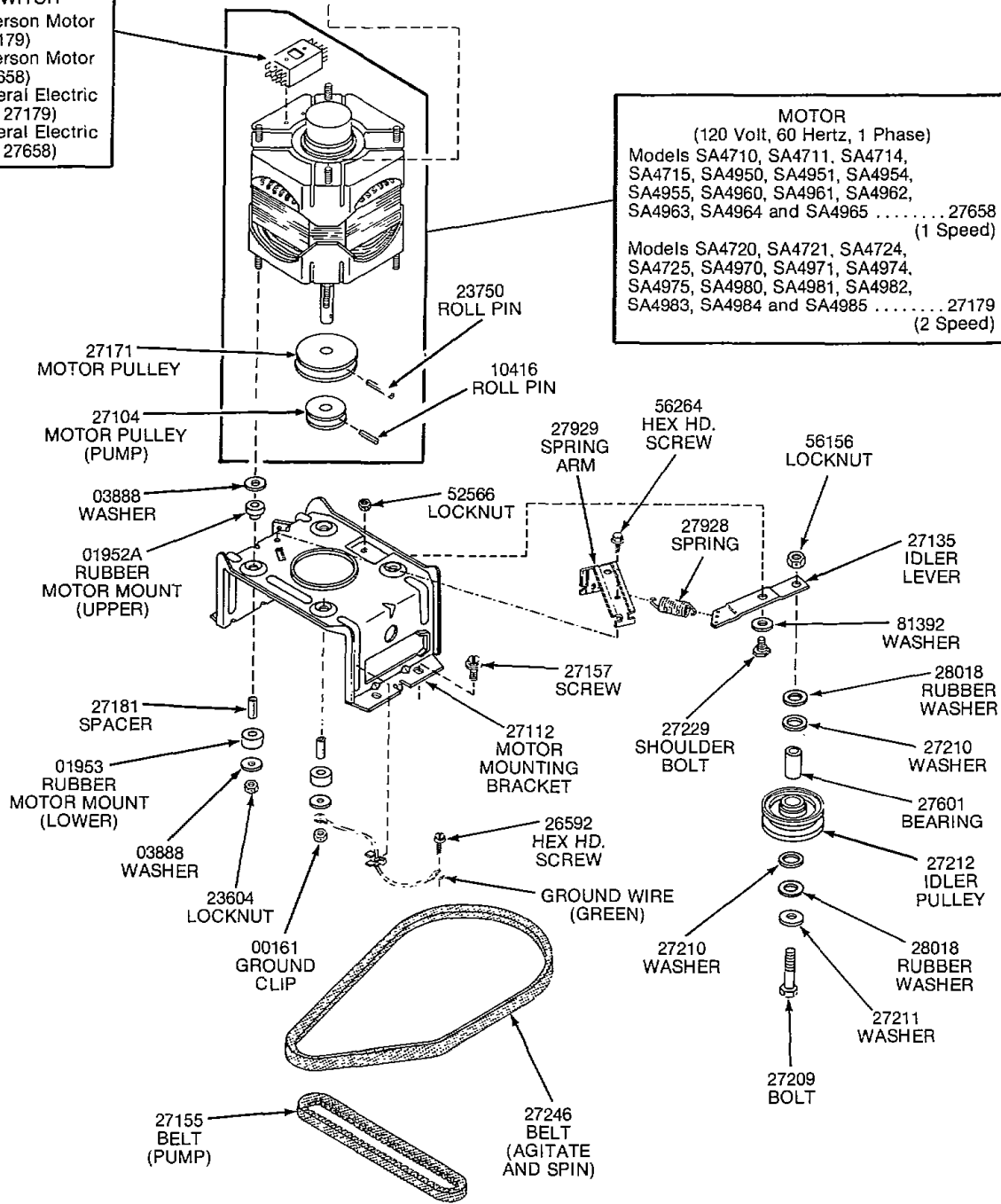

**MOTOR, MOUNTING BRACKET, BELTS AND IDLER ASSEMBLY**  
(through Serial No. F1094692)

**MOTOR SWITCH**  
 24139 (for Emerson Motor No. 27179)  
 24140 (for Emerson Motor No. 27658)  
 24142 (for General Electric Motor No. 27179)  
 24149 (for General Electric Motor No. 27658)

**258P3 CAPACITOR KIT**  
 (For use in areas where low voltage exists.)

**MOTOR**  
 (120 Volt, 60 Hertz, 1 Phase)  
 Models SA4710, SA4711, SA4714, SA4715, SA4950, SA4951, SA4954, SA4955, SA4960, SA4961, SA4962, SA4963, SA4964 and SA4965 ..... 27658 (1 Speed)  
 Models SA4720, SA4721, SA4724, SA4725, SA4970, SA4971, SA4974, SA4975, SA4980, SA4981, SA4982, SA4983, SA4984 and SA4985 ..... 27179 (2 Speed)

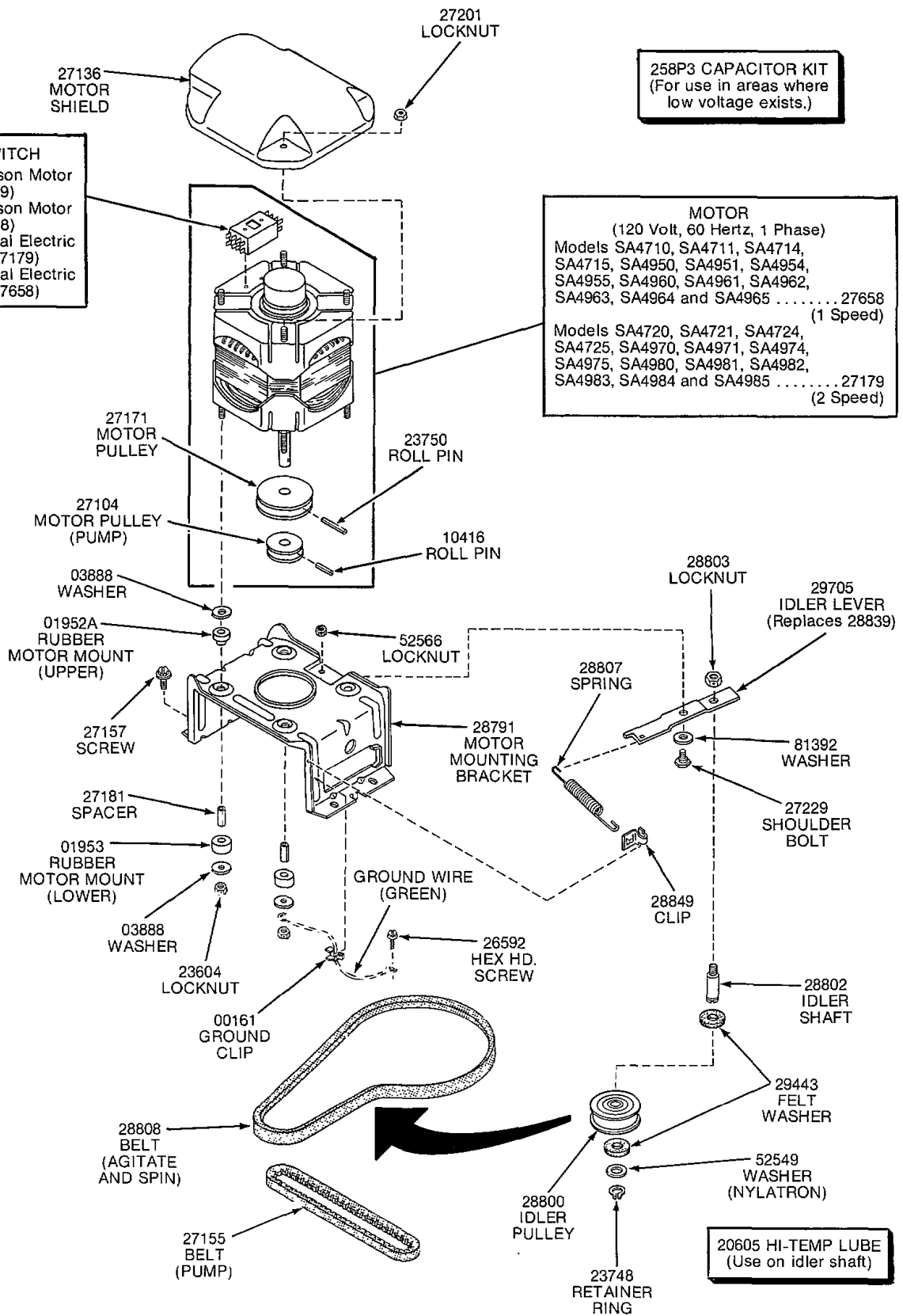

**MOTOR, MOUNTING BRACKET, BELTS AND IDLER ASSEMBLY**  
 (starting Serial No. F1094693)

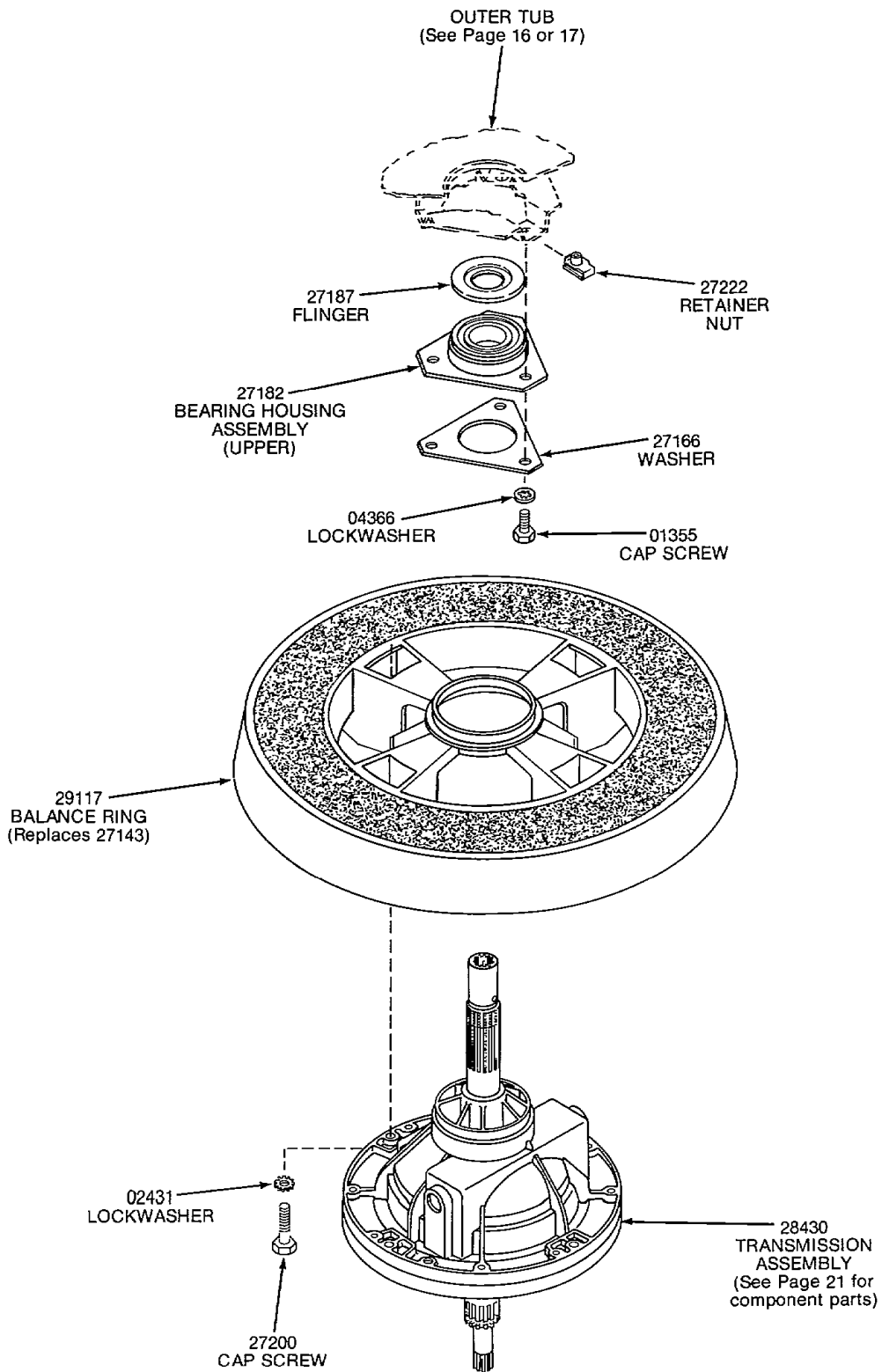

**TRANSMISSION ASSEMBLY AND BALANCE RING**

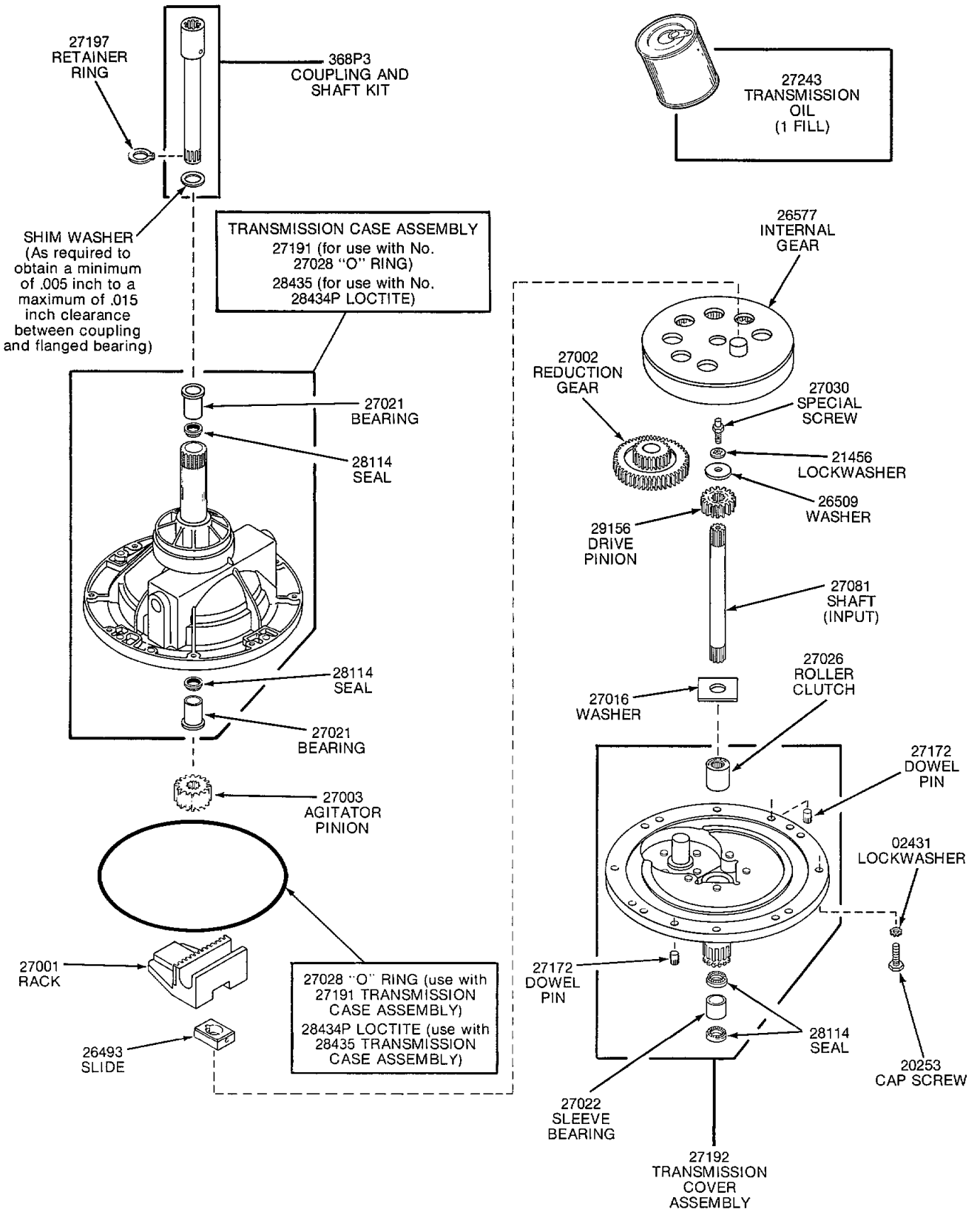

**TRANSMISSION ASSEMBLY**

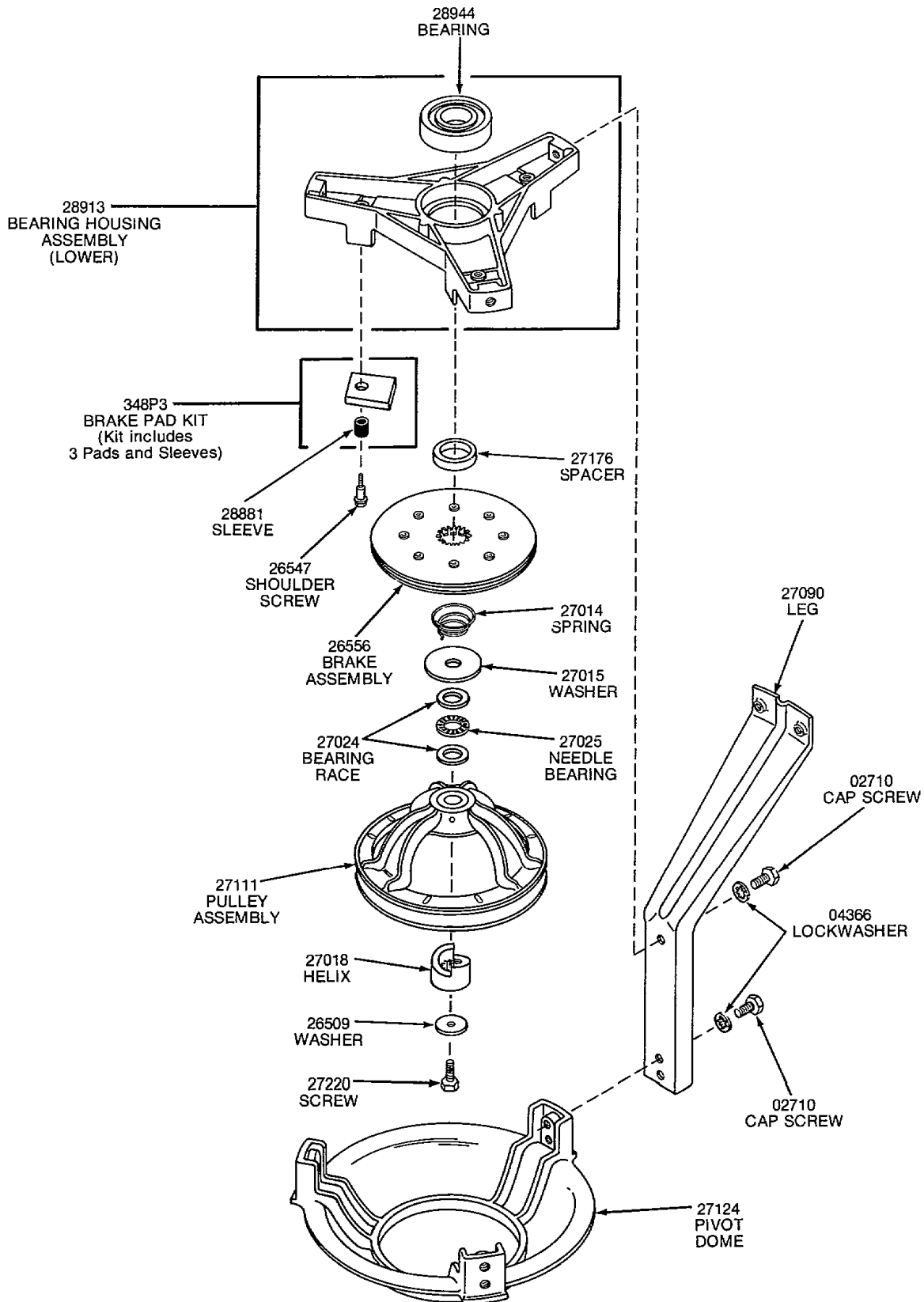

**BEARING HOUSING, BRAKE, PULLEY AND PIVOT DOME**

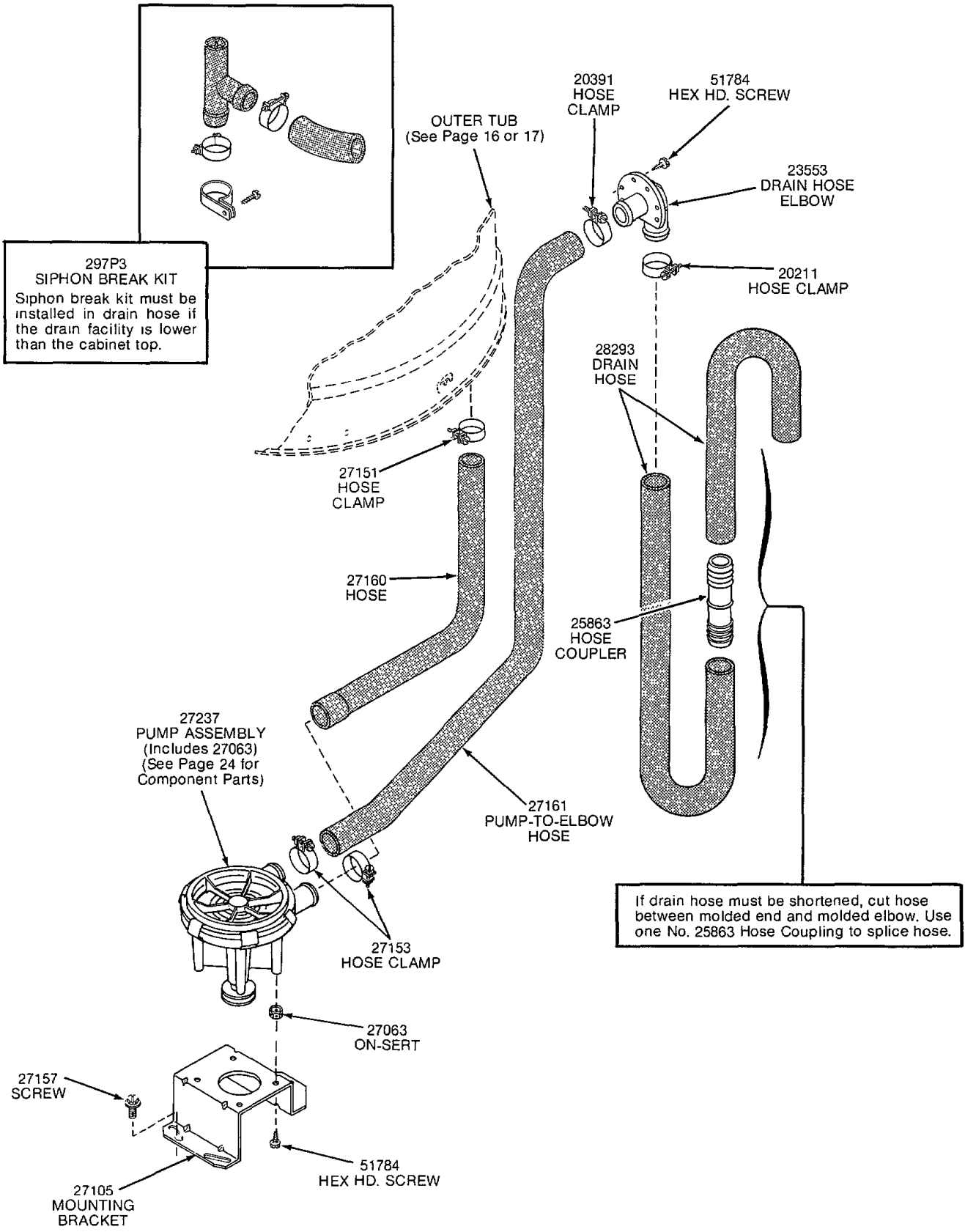

**PUMP ASSEMBLY, BRACKET, HOSES AND SIPHON BREAK KIT**



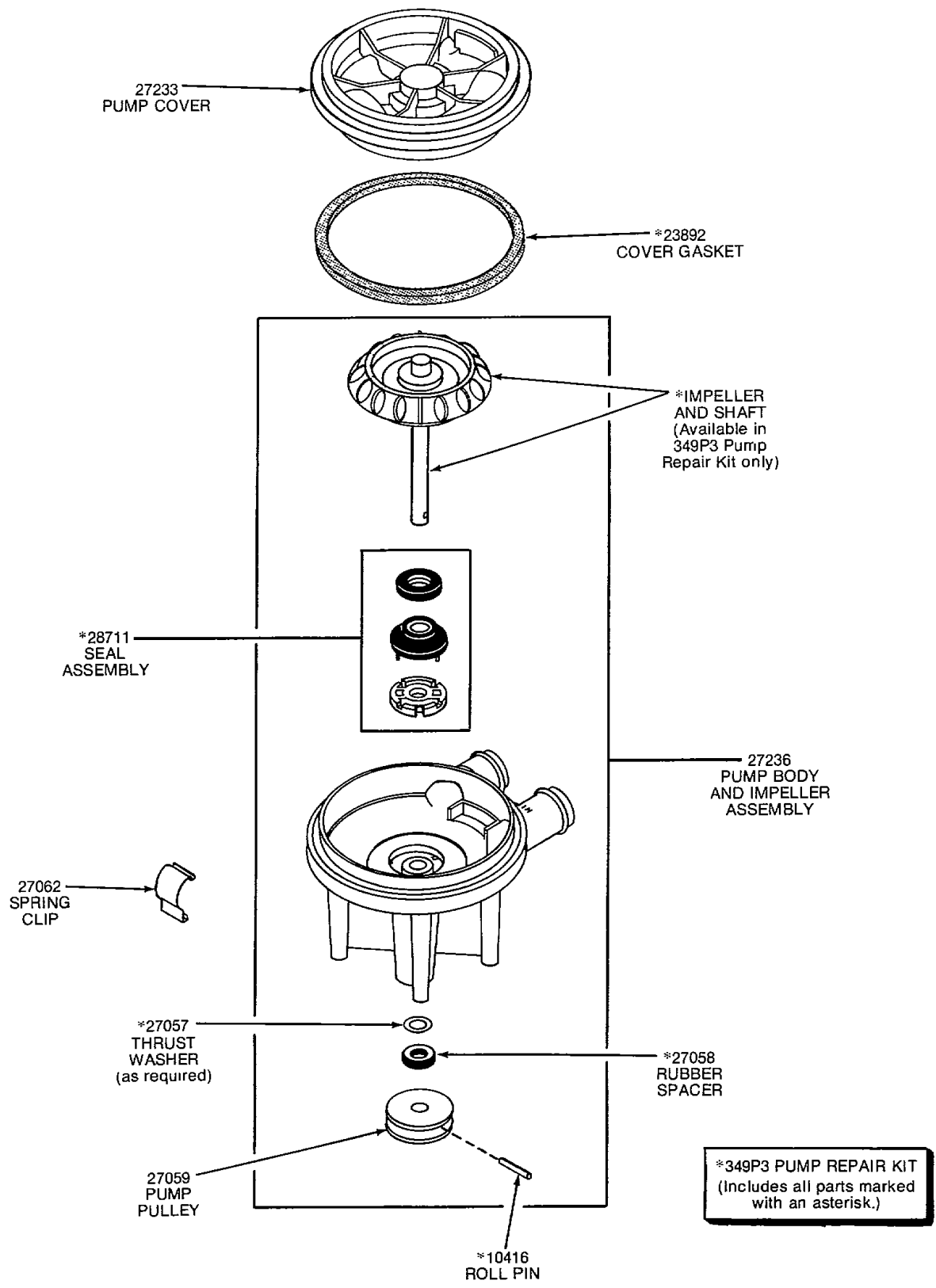

**PUMP ASSEMBLY**

ADD SUFFIX LETTER TO PART NUMBER TO DESIGNATE COLOR.  
**D** Apple Green      **H** Harvest Gold  
**L** Almond              **W** White

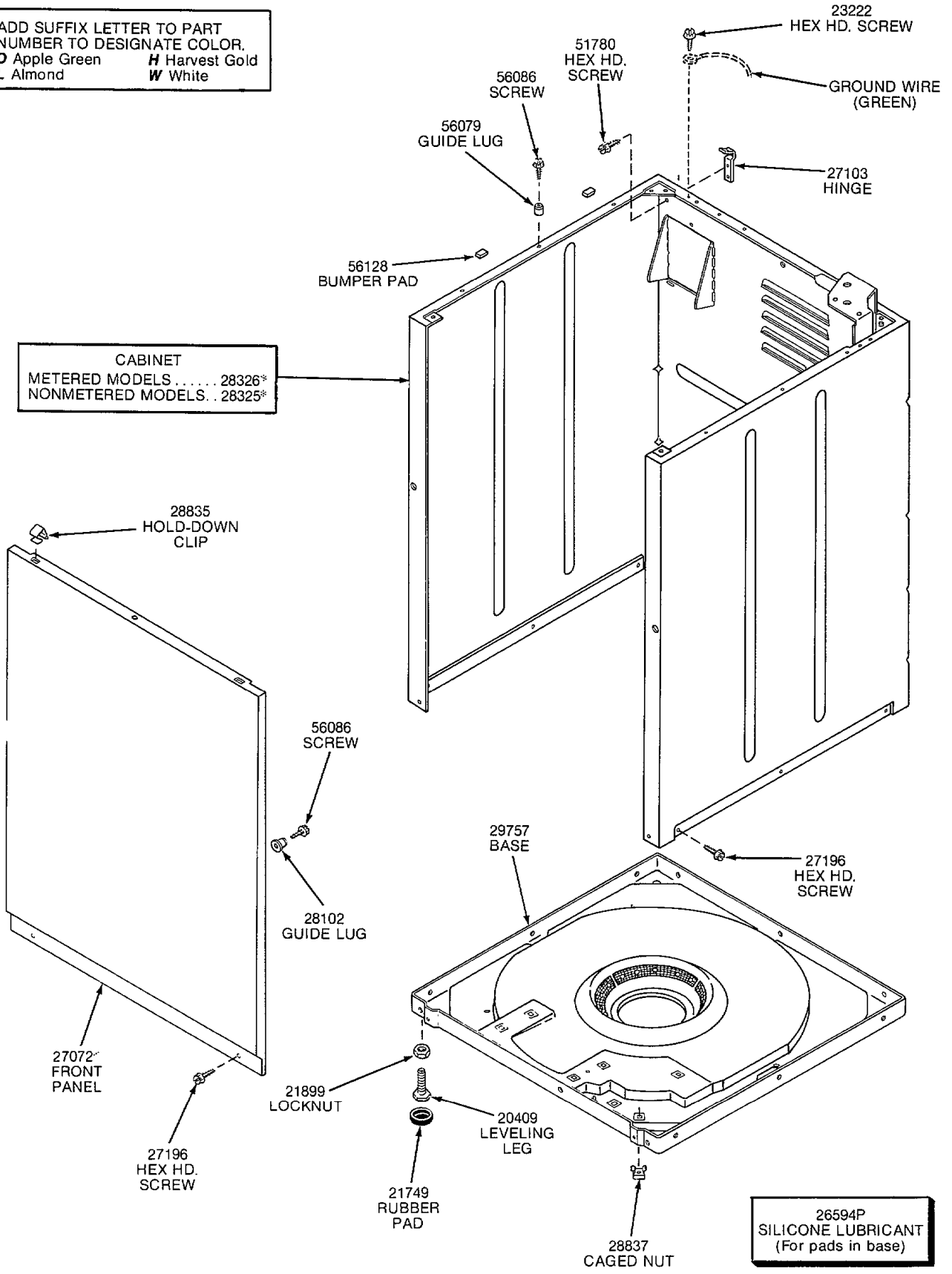

**FRONT PANEL, CABINET AND BASE**

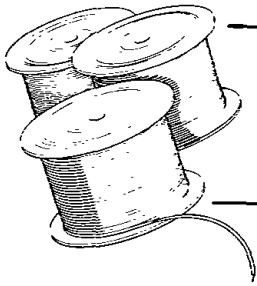

20680 18 GAUGE WIRE PER FOOT (SPECIFY COLOR)

ORDER BY THE FOOT. ALWAYS SPECIFY COLOR CODE REQUIRED.  
SEE WIRING DIAGRAM FOR CORRECT COLOR CODE.

INDIVIDUAL WIRES NOT SERVICED SEPARATELY. ORDER COMPLETE HARNESS OR  
ORDER BY THE FOOT AND NECESSARY TERMINALS AND CONNECTORS AS REQUIRED.

MODEL NUMBERS	SERIAL NUMBER	BASE HARNESS	TIMER HARNESS	HOOD HARNESS	LID SWITCH HARNESS	MOTOR WIRE HARNESS
SA4710, SA4711, SA4714, SA4715, SA4950, SA4951, SA4954, SA4955, SA4960, SA4961, SA4962, SA4963, SA4964 and SA4965	through serial number 100H5996	27749	27758	27923	27873	26144
	starting serial number 100H5997	28146	28217	28215	27873	28132
SA4720, SA4721, SA4724, SA4725, SA4970, SA4971, SA4974, SA4975, SA4980, SA4981, SA4982, SA4983, SA4984 and SA4985	through serial number 100H6136	27750	27759	27922	27873	26062
	starting serial number 100H6137	28143	28216	28214	27873	28131

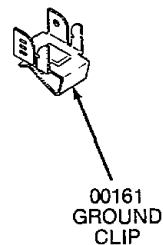
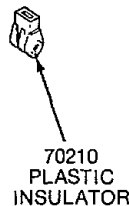
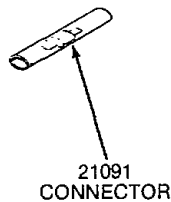
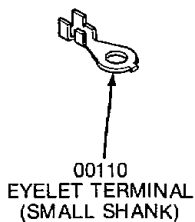
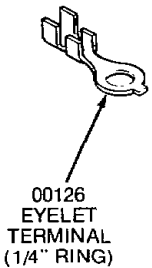
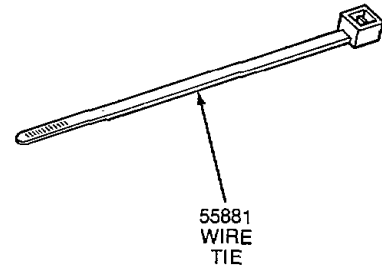
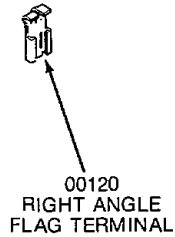
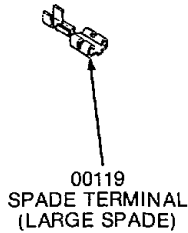
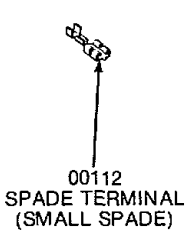
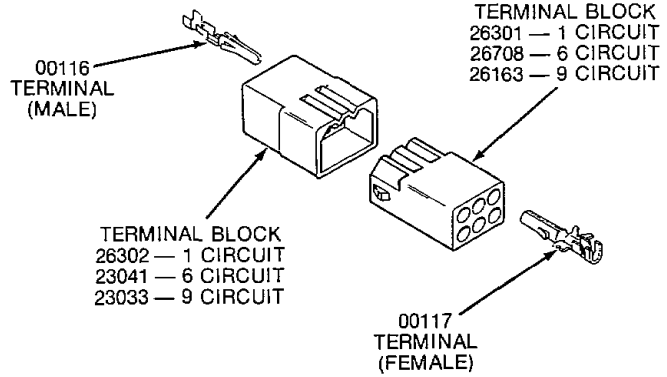
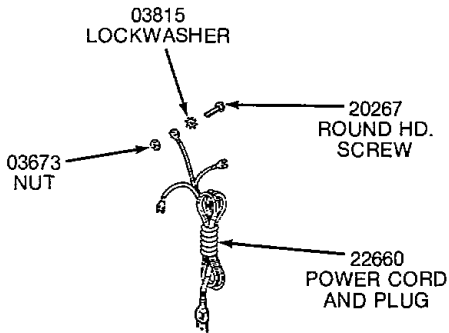

**POWER CORD, WIRE AND TERMINALS**

# SECTION II

## Service Procedures

### WARNING

Disconnect power cord and close water supply valves before servicing washer.

**IMPORTANT:** When reference is made to directions (right or left) in this manual, it is from the operator's position facing the front of the washer.

### 1. CONTROL PANEL (Refer to Figure 1)

- a. Remove two control panel attaching screws and lift assembly off panel support.

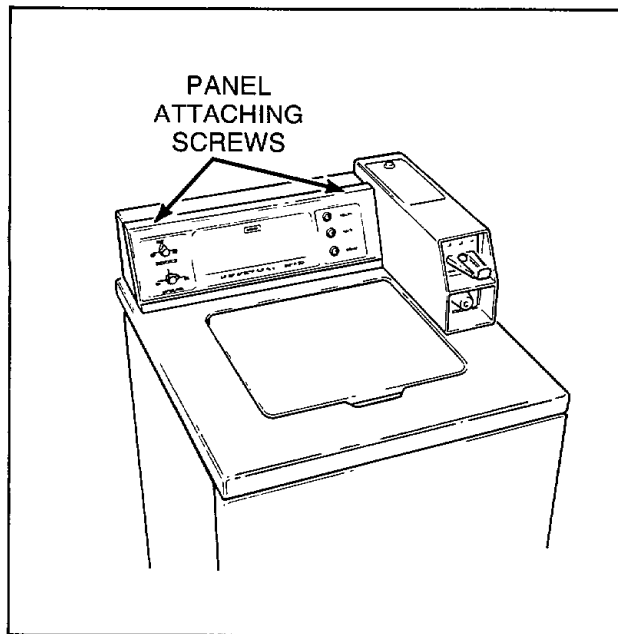

Figure 1

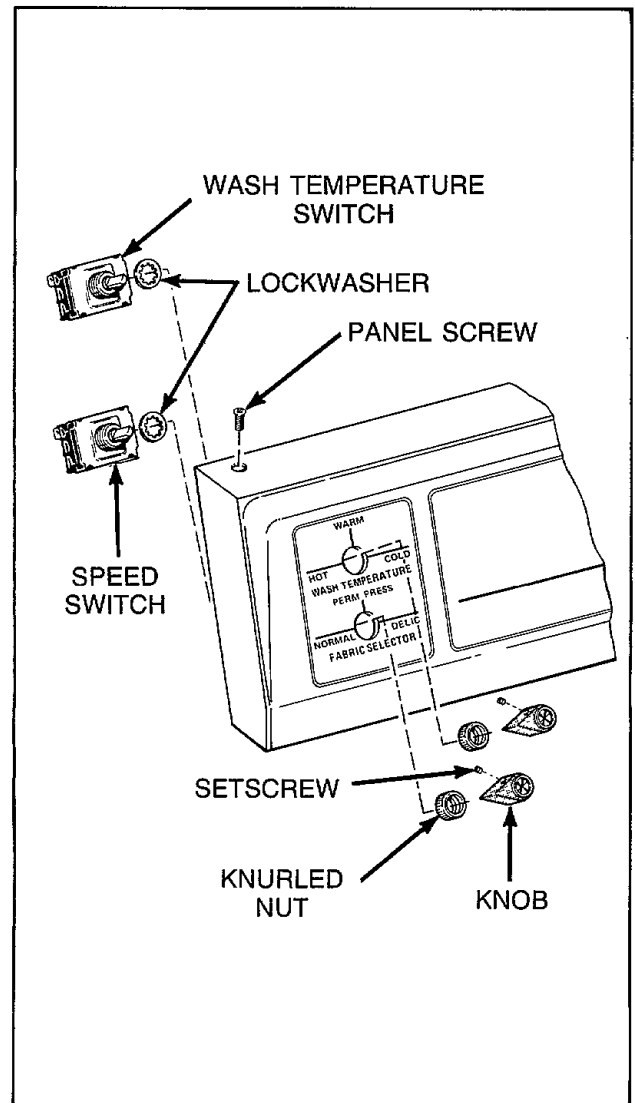

Figure 2

### 2. SPEED OR WASH TEMPERATURE SWITCH (Refer to Figure 2)

- a. Remove two control panel attaching screws and lift assembly off panel support.
- b. Loosen setscrew holding switch knob to switch shaft.
- c. Remove knurled nut holding switch to control panel.

**NOTE:** Lockwasher must be between switch and control panel when installing switch.

- d. Disconnect wires from switch.

**NOTE:** Refer to appropriate wiring diagram when rewiring switch.

### 3. INDICATOR LIGHTS (WASH, RINSE, SPIN, OR UNBALANCED LOAD)

- a. Remove two control panel attaching screws and lift assembly off panel support.
- b. Disconnect wires from light.
- c. Squeeze locking tabs together and push light out toward front of panel.

**NOTE:** Refer to appropriate wiring diagram when rewiring light.

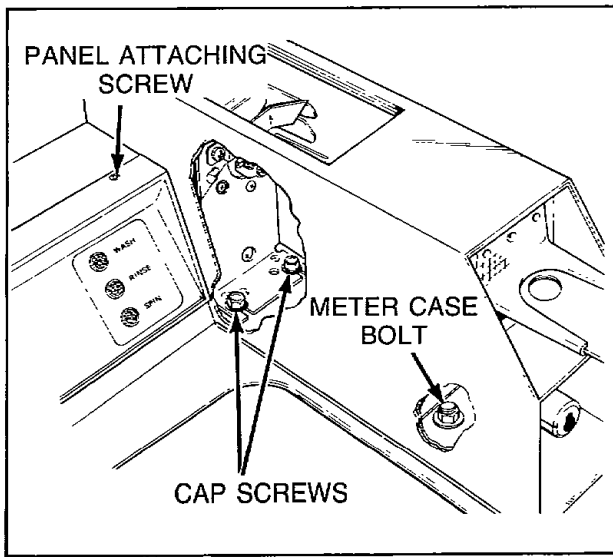

Figure 3

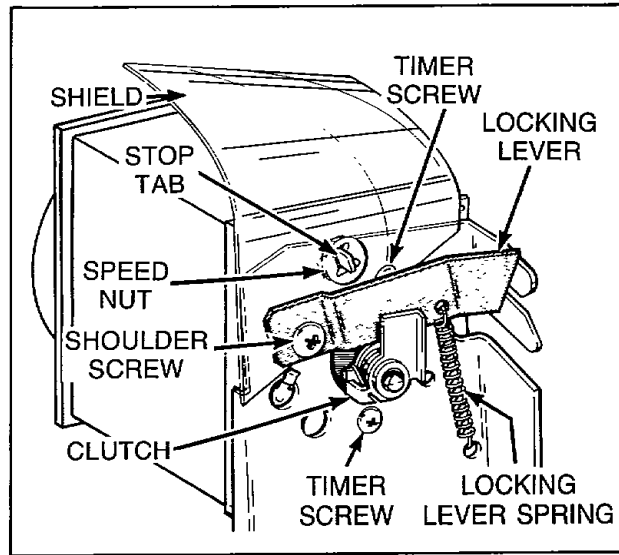

Figure 4

#### 4. TIMER ASSEMBLY - Metered Models

- a. Unlock and remove service door.
- b. Remove two timer bracket cap screws, *Figure 3* and pull timer bracket and timer up and out of meter case through service door opening as far as wires will permit.
- c. Pull wire harness and blocks through into meter case, then disconnect timer harness from control hood harness at quick disconnect block.
- d. (Models equipped with Mallory Timer) - Remove shoulder screw, locking lever and spring, *Figure 4*.

**NOTE:** When locking lever and spring are installed, they must be positioned as shown in *Figure 4*, and must pivot freely on shoulder screw.

- e. Loosen Bristol setscrew holding clutch to timer shaft.
- f. Remove remaining screw(s) holding shield (if present) and timer to bracket.
- g. Disconnect wires from timer.

**NOTE:** Refer to appropriate wiring diagram when rewiring timer.

**IMPORTANT:** Timer bracket must be installed with bosses on bottom of timer bracket fitting into holes in meter case, and clutch must be positioned as shown in *Figure 5*. Locking lever (models equipped with Mallory Timer) must drop behind clutch when timer shaft is pulled out, and must be lifted by inner end of coin slide (allowing timer shaft to move in) when slide is actuated.

#### 5. TIMER ASSEMBLY - Non-Metered Models (Refer to *Figure 6*)

- a. Loosen two setscrews holding timer knob to timer shaft.

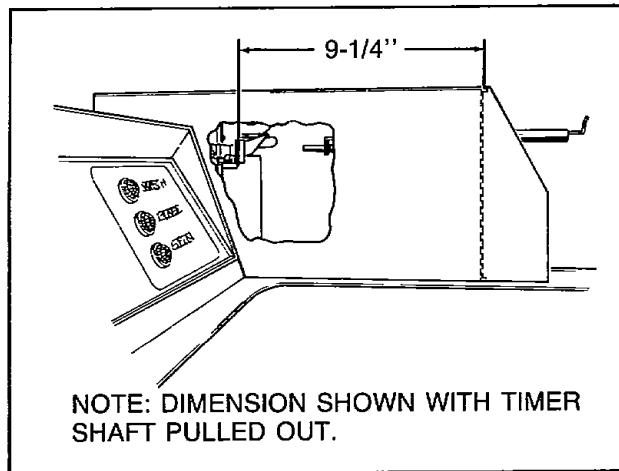

Figure 5

- b. Remove four screws and lockwashers holding timer and plate to timer case.

**NOTE:** When installing, lockwashers must be between heads of screws and timer plate.

- c. Pull timer and plate out as far as wires will permit.

**NOTE:** Kingston Timer - Disconnect ground wire from rear of timer.

- d. Pull wire harness and blocks through into timer housing, then disconnect timer harness from control hood harness at quick disconnect block.
- e. Remove two screws holding timer to timer plate.
- f. Disconnect wires from timer.

**NOTE:** Refer to appropriate wiring diagram when rewiring timer.

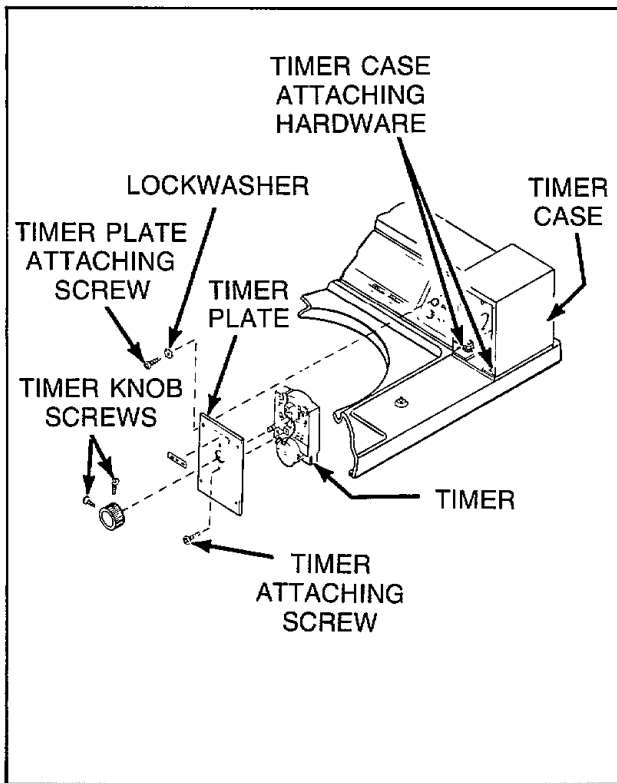

Figure 6

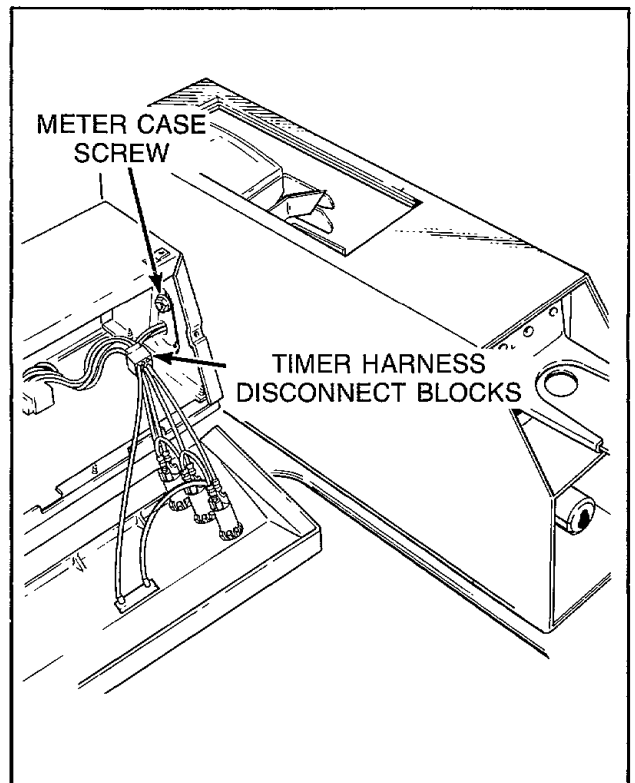

Figure 7

## 6. METER CASE

- a. Unlock and remove service door.
- b. Remove two cap screws holding timer bracket to cabinet top, *Figure 3*.
- c. Remove two control panel attaching screws, *Figure 1*, and lift assembly off panel support.
- d. Disconnect timer harness from control hood harness at disconnect blocks, *Figure 7*.
- e. Remove timer, bracket and harness out through service door opening.
- f. Remove cap screw, lockwashers and nut holding meter case to end of control hood, *Figure 7*.
- g. Remove coin drawer.
- h. With loading door open, hold hand under front meter case bolt. Remove nut and lockwasher, *Figure 3*, and catch bolt and washers in hand.
- i. Carefully lift meter case off cabinet top.

## 7. TIMER CASE

- a. Remove timer assembly, paragraph 5.
- b. Remove two control panel attaching screws and lift assembly off panel support.
- c. Remove cap screw, lockwashers and nut holding timer case to control hood.
- d. Remove two screws from bottom edge of front panel, *Figure 8*.
- e. Pull bottom of panel away from washer until hold-down clips (located on top flange of panel) disengage from slots in cabinet top, *Figure 8*.

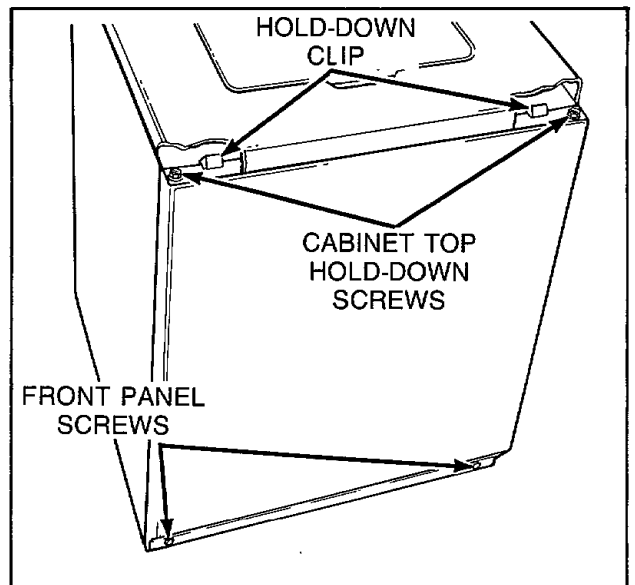

Figure 8

- f. Remove two cabinet top hold-down screws, *Figure 8*.
- g. Tape loading door closed and lift cabinet top to a vertical position.
- h. Remove carriage bolt, washer, lockwashers, and nuts holding timer case to cabinet top, *Figure 6*.
- i. Support timer case and remove screw and fiber washer holding rear of case to cabinet top.

## 8. PRESSURE SWITCH

- Remove control panel assembly screws and lift off panel support.
- Remove two screws holding switch to mounting bracket.
- Pull switch out of control hood far enough to disconnect pressure hose and wires from switch.

**NOTE:** Refer to appropriate wiring diagram when rewiring switch.

**IMPORTANT:** When installing pressure switch, blow air into hose before connecting hose to switch to remove any moisture that may have accumulated in the hose.

## 9. DRAIN HOSE ELBOW (Refer to Figure 9)

- Loosen hose clamp and remove drain hose from elbow.
- Remove screws holding elbow to rear of washer cabinet.
- Pull elbow out through opening in cabinet far enough to permit loosening inner clamp, then remove elbow from inner hose.

**NOTE:** When installing elbow on inner hose, DO

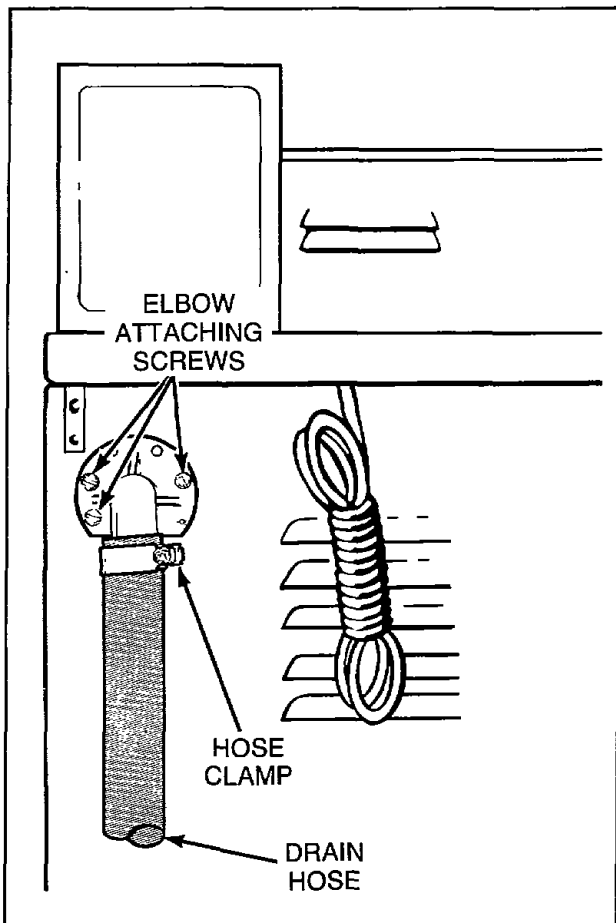

Figure 9

NOT allow hose inside washer to twist! Direct elbow toward drain receptacle before tightening the inner hose clamp. If this is not done, the inner hose will twist in the direction of the outer tub resulting in the hose rubbing against the bottom edge of the outer tub.

- Secure elbow to washer cabinet using the screws removed in step "b".

## 10. LOADING DOOR (Refer to Figure 10)

- Depress tab on either hinge, then slide hinge out of loading door and bushing in cabinet top.
- Tilt loading door slightly and slide door and hinge out of opposite bushing.

## 11. AGITATOR POST ASSEMBLY

### WARNING

If water is present in washtub, spin and pump out before removing agitator post assembly.

- Remove agitator hold-down cap, or load level indicator, and lift agitator out of washtub, Figure 10.

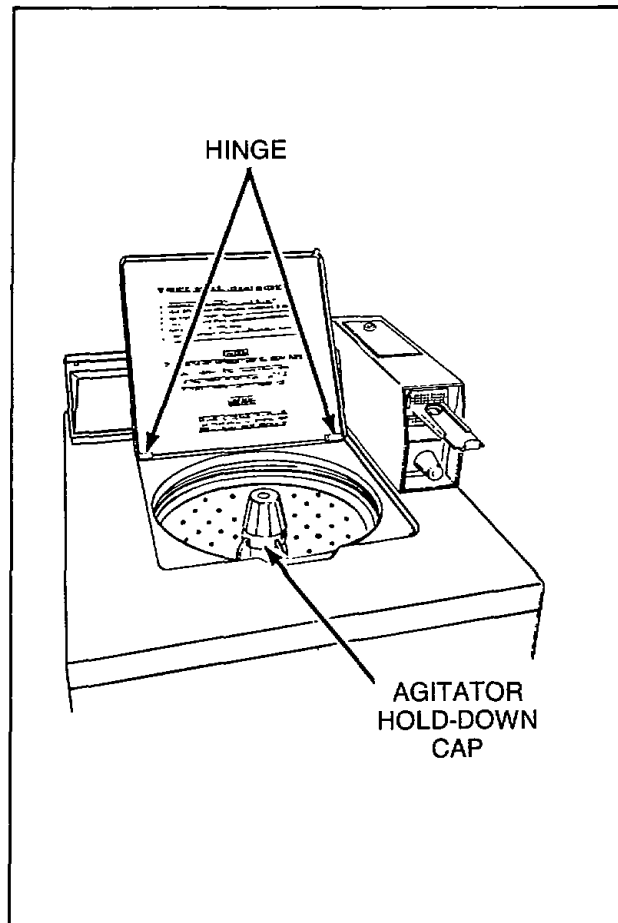

Figure 10

- b. Remove four cap screws holding agitator post assembly to washtub hub, *Figure 11*, then lift assembly out of washtub.

**NOTE: Models equipped with gasket,** use a new gasket when installing agitator post. (Be sure all traces of old gasket are removed from the tub and agitator post.) Apply a small bead of sealant, No. 27615, to each of the sealing surfaces where the agitator post gasket will contact the hub. Carefully place new gasket, No. 27020, on hub. Be sure holes in gasket are aligned with bolt holes in hub.

**Models equipped with Loctite -** Be sure all traces of old Loctite are removed from the hub and agitator post. Apply approximately a 1/16 diameter continuous bead of No. 28434P Loctite to the embossed surfaces of the agitator post, *Figure 12*.

- c. When reinstalling agitator post, and while tightening the four cap screws, tap lightly on the drive block to force splines on drive shaft into the coupling on the transmission assembly.

## 12. AGITATOR DRIVE SHAFT (Refer to *Figure 13*)

- a. Remove agitator post assembly, paragraph 11.
- b. Remove retainer ring from bottom end of drive shaft, grasp agitator drive block and pull shaft out of agitator post.

**IMPORTANT:** Stainless steel washer must be between thrust bearing and fiber washer on agitator drive block when installing drive shaft.

**CAUTION:** Be careful when installing drive shaft in agitator post to prevent cutting seal lips with the splines on lower end of drive shaft.

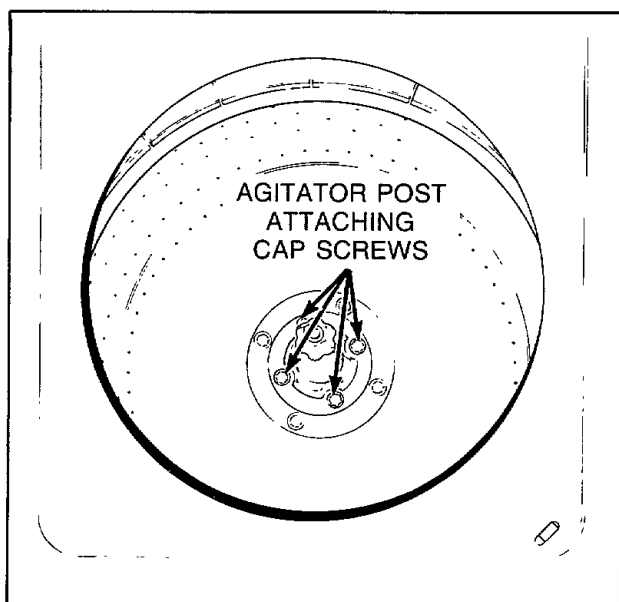

Figure 11

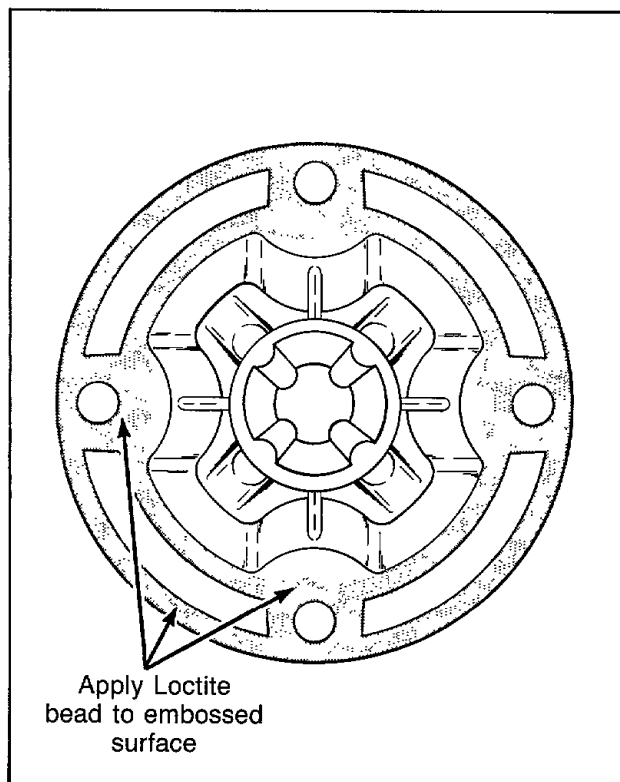

Figure 12

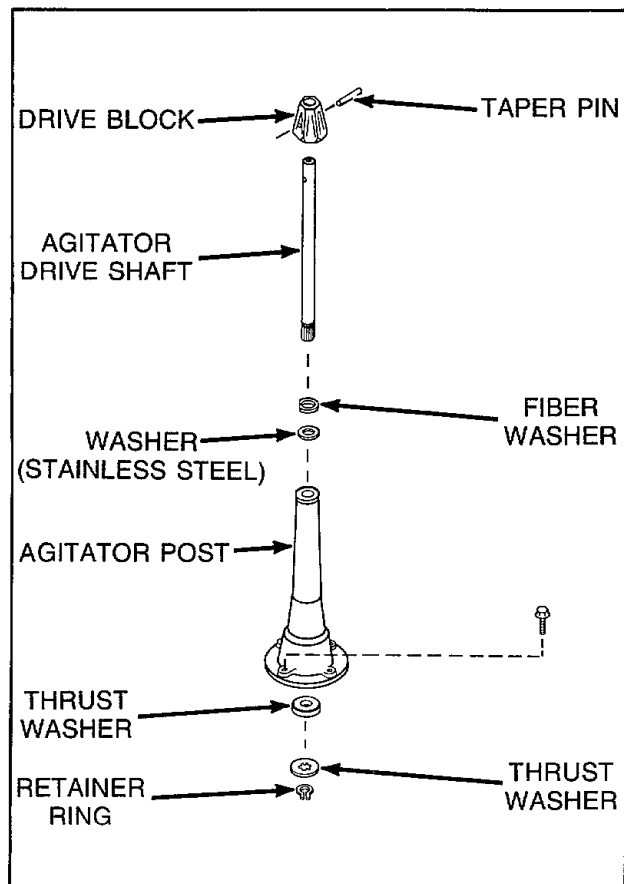

Figure 13



13. **FRONT PANEL** (Refer to Figure 14)

- a. Remove two screws from bottom edge of panel.
- b. Pull bottom of panel away from washer until hold-down clips (located on top flange of panel) disengage from slots in cabinet top.

**Hold-Down Clips**

Compress hold-down clips enough to remove from slots in top flange of panel.

**Guide Lugs**

Remove screws holding guide lugs to side flanges of front panel.

14. **PUMP BELT**

- a. Remove two screws from bottom edge of front panel, *Figure 14*.
- b. Pull bottom of panel away from washer until hold-down clips (located on top flange of panel) disengage from slots in cabinet top.
- c. Remove the two front mounting screws and loosen the rear mounting screw holding pump and bracket to washer base, *Figure 15*, shift pump assembly toward motor to loosen belt tension.

- d. Run belt off motor pulley, then remove belt from pump pulley.

**NOTE:** After installing pump belt, adjust belt, paragraph 36.

15. **DRIVE BELT**

**IMPORTANT:** If the washer is still equipped with the old style drive belt, No. 27246, and the old style idler lever and pulley assembly, we recommend that these parts be replaced with the No. 364P3 Idler Kit. This kit can be installed on washers by following the instructions supplied with the kit.

For washers equipped with the new style idler system, proceed as follows:

- a. Remove two screws from bottom edge of front panel, *Figure 14*.
- b. Pull bottom of panel away from washer until hold-down clips (located on top flange of panel) disengage from slots in cabinet top, *Figure 14*.
- c. Remove two front mounting screws and loosen the rear mounting screw holding pump and bracket to washer base, *Figure 15*, pivot entire assembly toward motor to loosen belt tension.

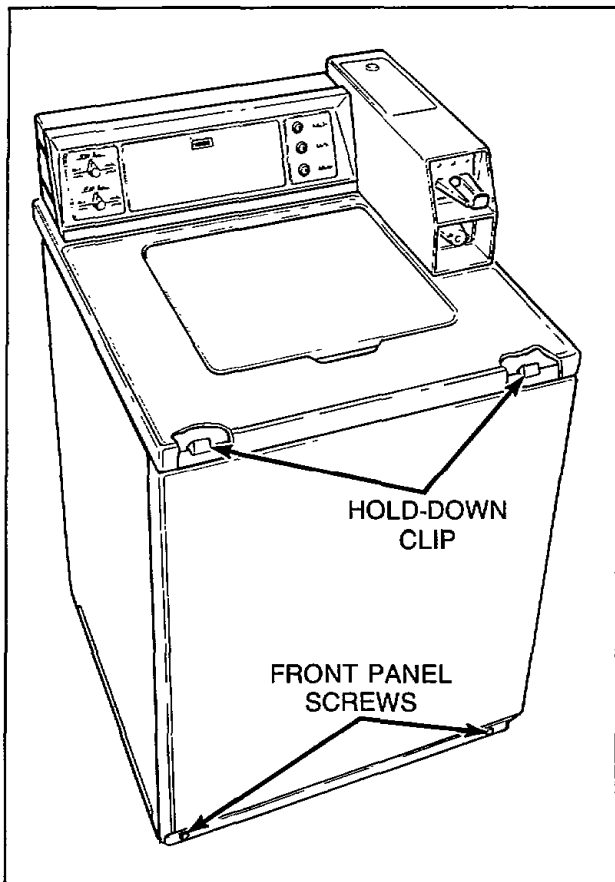

Figure 14

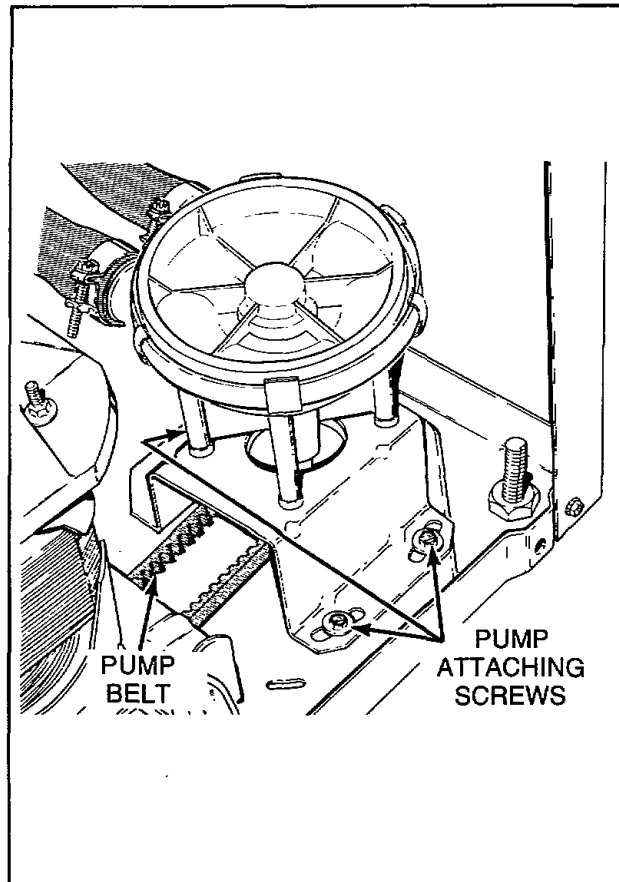

Figure 15

- d. Run belt off motor pulley, then remove belt from pump pulley.

**NOTE:** After installing belt, adjust belt, paragraph 36.

- e. Reach in through front of motor mount and move idler lever to the left to release tension on belt, *Figure 16*.

**IMPORTANT:** Use caution when releasing idler lever tension. If the idler spring is overstretched, it will affect the washer operation.

- f. While holding idler lever, reach around right side of motor and run belt off right side of large drive pulley, *Figure 16*.  
g. Remove belt from motor pulley and pull belt out through front of motor mount.

**IMPORTANT:** Drive belt **MUST** be replaced with belt No. 28808 (special clutch type belt) for proper washer operation.

## TO INSTALL NO. 28808 DRIVE BELT

**NOTE:** If the new belt is replacing a burned belt, the motor pulley "V" groove must be polished with fine (320 grit) emery cloth to remove rubber residue. If this residue is not removed it will affect the washer spin operation.

- a. Push belt in through front of motor mount and place belt on motor pulley.  
b. Reach in and around right side of motor, starting with belt on right side of large drive pulley, run belt onto pulley, *Figure 16*.  
c. Reach in through front of motor mount and move idler lever to the left.

**IMPORTANT:** Do not overstretch idler spring as it will affect the washer operation.

- d. While holding idler lever, reach around right side of motor and place belt on idler pulley. **IDLER PULLEY MUST RIDE ON OUTSIDE OF BELT.**

(continued)

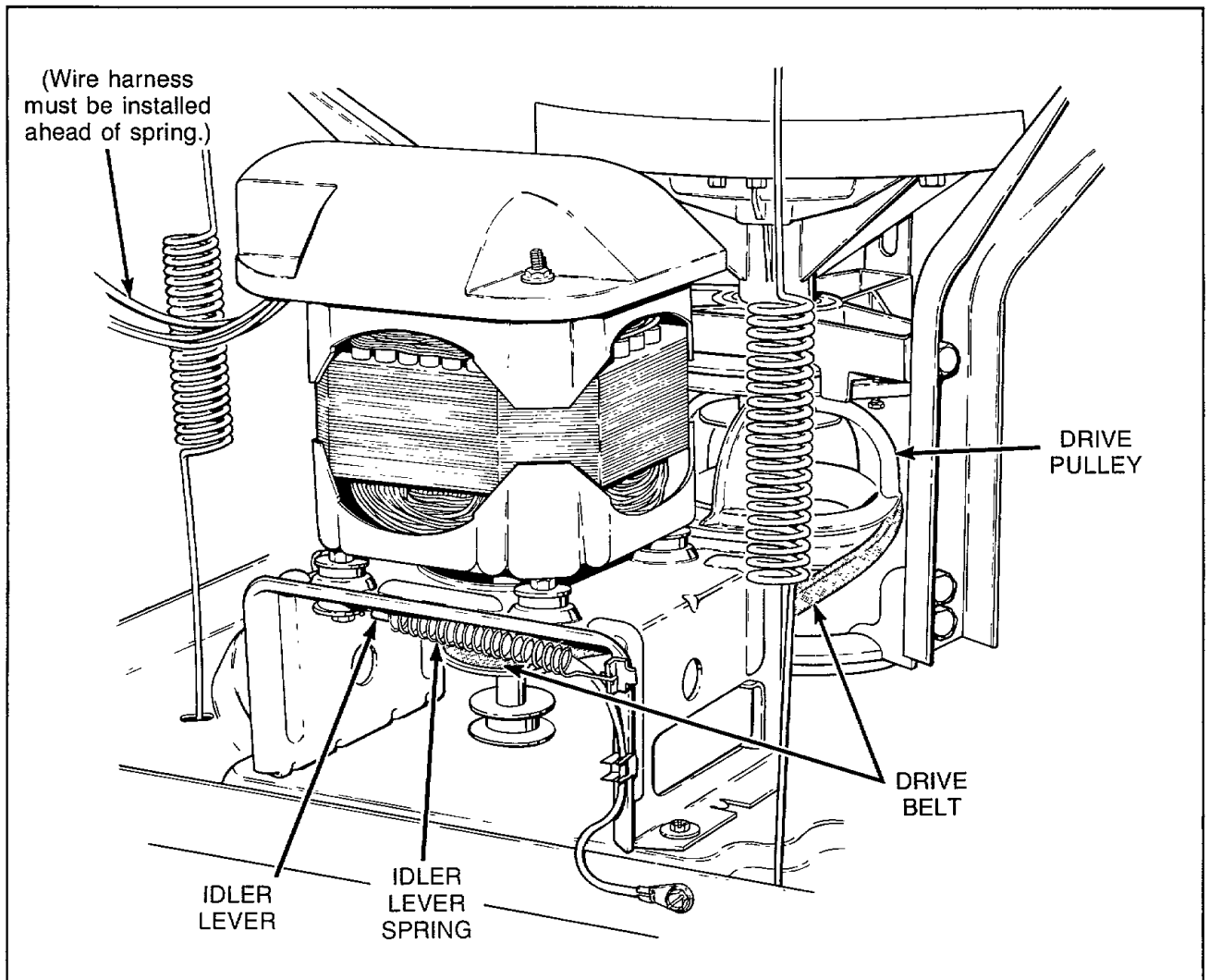

Figure 16

**NOTE:** There is no belt adjustment after installing new drive belt. Check to be sure the motor and mounting bracket has been shifted toward rear of washer to its limit of travel within the mounting bracket attaching screws. If the motor and mounting bracket must be repositioned, loosen the four motor attaching screws, *Figure 17*, and shift motor and mounting bracket toward rear of washer to its limit of travel. Retighten the four attaching screws, *Figure 17*.

## 16. MOTOR AND MOUNTING BRACKET

- a. Remove front panel, paragraph 13.
- b. Disconnect motor wire harness plug from base wire harness receptacle.
- c. Remove pump belt, paragraph 14, then remove drive belt, paragraph 15.

**NOTE:** When installing belts, adjust pump belt, paragraph 36. There is no drive belt adjustment.

- d. Remove screw holding ground wire to washer base, *Figure 17*.

- e. Remove four screws holding motor and mount-washer to its limit of travel within the mounting bracket attaching screws.

- f. Remove nuts, steel washers, spacers and rubber mounts holding motor to mounting bracket, *Figure 18 or 19*. Lift motor off mounting bracket and remove balance of rubber mounts and steel washers from motor mounting studs. Shift motor and mounting bracket to washer base, *Figure 17*, then lift complete assembly out of washer.

**NOTE:** When installing motor and mounting bracket, tab on right bottom flange of mounting bracket must be placed in positioning hole in base. Mounting bracket must be shifted toward rear of

**IMPORTANT:** When installing motor on mounting bracket, position motor with switch facing toward left side of mounting bracket.

**NOTE:** Refer to *Figure 18 or 19* for motor and mounting bracket assembly sequence.

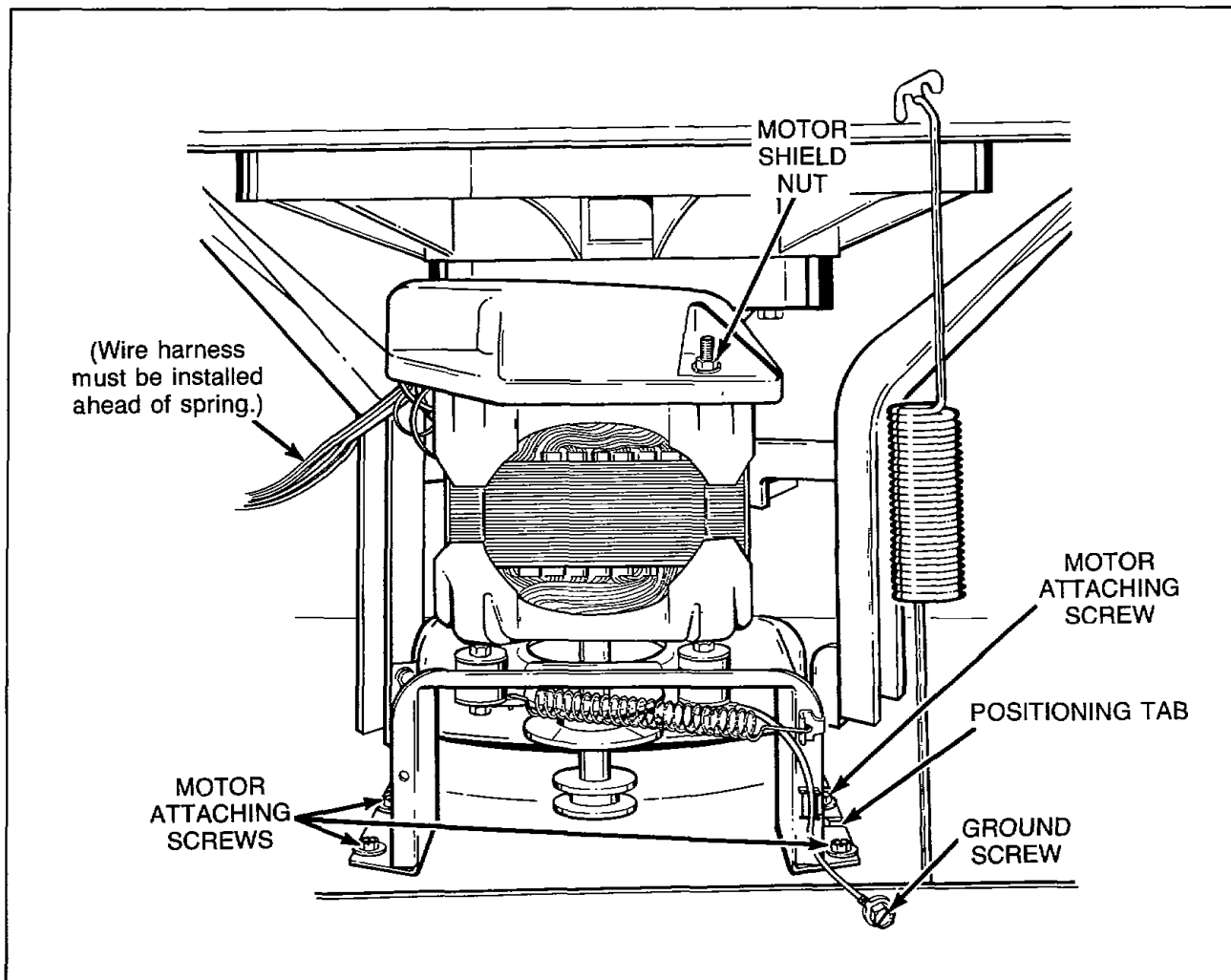
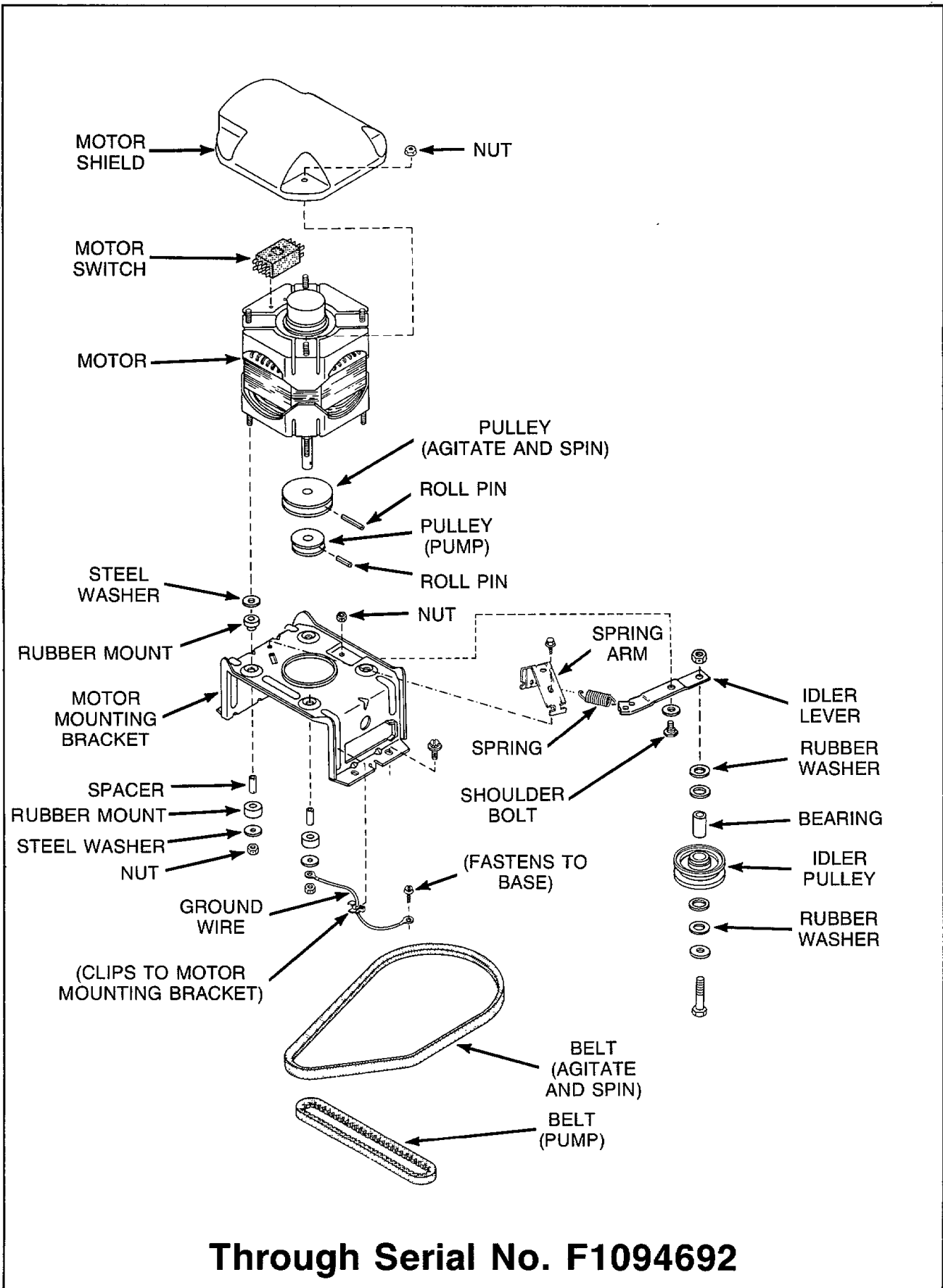

Figure 17



**Through Serial No. F1094692**

Figure 18

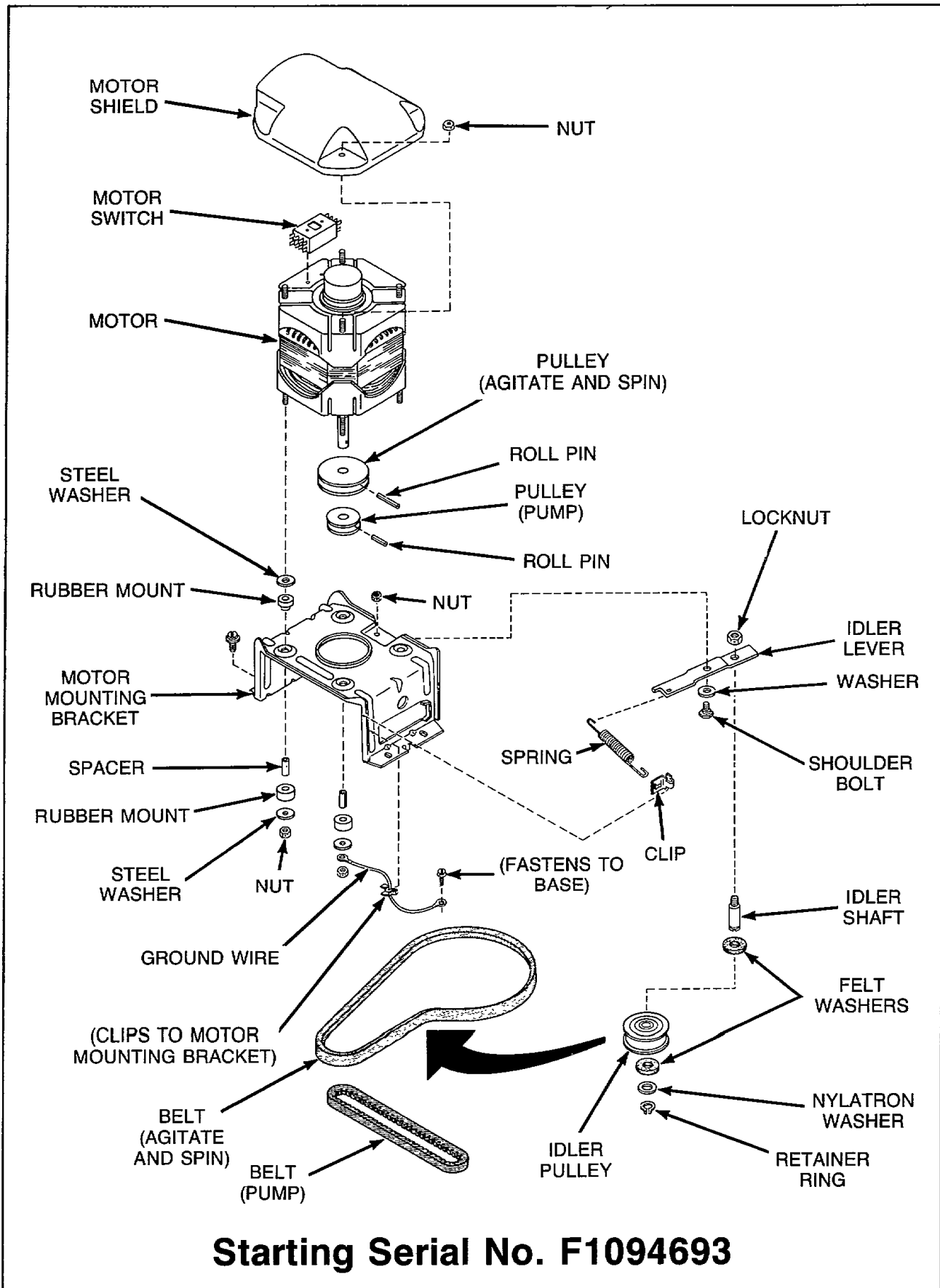

Figure 19

## 17. IDLER LEVER AND PULLEY

- a. Remove two screws from bottom edge of front panel, *Figure 14*.
- b. Pull bottom of panel away from washer until hold-down clips (located on top flange of panel) disengage from slots in cabinet top, *Figure 14*.
- c. Disconnect motor wire harness from base wire harness at quick disconnect blocks.
- d. Remove the two front mounting screws and loosen the rear mounting screw holding pump and bracket to washer base, *Figure 15*, shift pump assembly toward motor to loosen belt tension.
- e. Run pump belt off motor pulley.

**NOTE:** When installing pump belt, adjust belt, paragraph 36.

- f. Reach in through front of motor mount and move idler lever to the left to release tension on drive belt, *Figure 16*.

**IMPORTANT:** Use caution when releasing idler lever tension. If the idler spring is overstretched, it will affect the washer operation.

- g. While holding idler lever, reach around right side of motor and run drive belt off right side of large drive pulley, *Figure 16*, then remove belt from motor pulley.
- h. Remove screw holding ground wire to washer base, *Figure 17*.
- i. Remove four screws holding motor and mounting bracket to washer base, *Figure 17*, then lift complete assembly out of washer.

**NOTE:** When installing motor and mounting bracket, tab on right bottom flange of mounting bracket must be placed in positioning hole in base. Mounting bracket must be shifted toward rear of washer to its limit of travel within the mounting bracket attaching screws.

- j. Remove nut, washer and shoulder bolt holding idler lever and pulley to motor mounting bracket.

**NOTE:** Refer to *Figure 18 or 19* for idler lever and pulley assembly sequence.

- k. When installing idler lever and pulley assembly, apply No. 21814 Lubricant to the area of the idler lever making contact with the motor mounting bracket.

## 18. MOTOR DRIVE PULLEY OR PUMP PULLEY

- a. Remove two screws from bottom edge of front panel, *Figure 14*.

- b. Pull bottom of panel away from washer until hold-down clips (located on top flange of panel) disengage from slots in cabinet top, *Figure 14*.
- c. Disconnect motor wire harness from base wire harness at quick disconnect blocks.
- d. Remove the two front mounting screws and loosen the rear mounting screw holding pump and bracket to washer base, *Figure 15*, pivot entire assembly toward motor to loosen belt tension.
- e. Run pump belt off motor pulley.

**NOTE:** When installing pump belt, adjust belt, paragraph 36.

- f. Reach in through front of motor mount and move idler lever to the left to release tension on drive belt, *Figure 16*.

**IMPORTANT:** Use caution when releasing idler lever tension. If the idler spring is overstretched, it will affect the washer operation.

- g. While holding idler lever, reach around right side of motor and run drive belt off right side of large drive pulley, *Figure 16*, then remove belt from motor pulley.
- h. Remove screw holding ground wire to washer base, *Figure 17*.
- i. Remove four screws holding motor and mounting bracket to washer base, *Figure 17*, then lift complete assembly out of washer.

**NOTE:** When installing motor and mounting bracket, tab on right bottom flange of mounting bracket must be placed in positioning hole in base. Mounting bracket must be shifted toward rear of washer to its limit of travel within the mounting bracket attaching screws.

- j. Lay motor and mounting bracket on its side.

**NOTE:** To remove pulleys, support motor shaft (to prevent bend of the shaft) and carefully drive out pulley roll pins.

## 19. MOTOR SWITCH

- a. Remove front panel, paragraph 13.
- b. Remove nut holding motor shield to motor, *Figure 17*.
- c. Disconnect external wires from motor switch terminals.

**NOTE:** Refer to appropriate wiring diagram when rewiring switch.

- d. Remove two screws holding switch to motor.
- e. Disconnect internal motor leads from switch terminals.

## 20. PUMP ASSEMBLY

- a. Remove front panel, paragraph 13.
- b. Remove the two front pump attaching screws, *Figure 20*, and loosen the rear screw.

**NOTE:** Rear screw hole in pump mounting bracket is slotted, therefore, it is not necessary to remove the rear screw.

- c. Run the pump belt off motor pulley, then remove belt from pump pulley.

**NOTE:** When installing pump belt, adjust belt, paragraph 36.

- d. Slide pump and mounting bracket toward rear of washer and lift pump assembly out of washer.

**CAUTION:** There will always be some water that will remain in the outer tub, therefore, before removing the hoses from the pump, the hoses will have to be pinched off or drained to prevent water spillage on the floor.

- e. Loosen hose clamps and remove hoses from pump assembly, *Figure 20*.

**NOTE:** When installing drain elbow-to-pump hose, DO NOT allow the hose to twist! Direct the

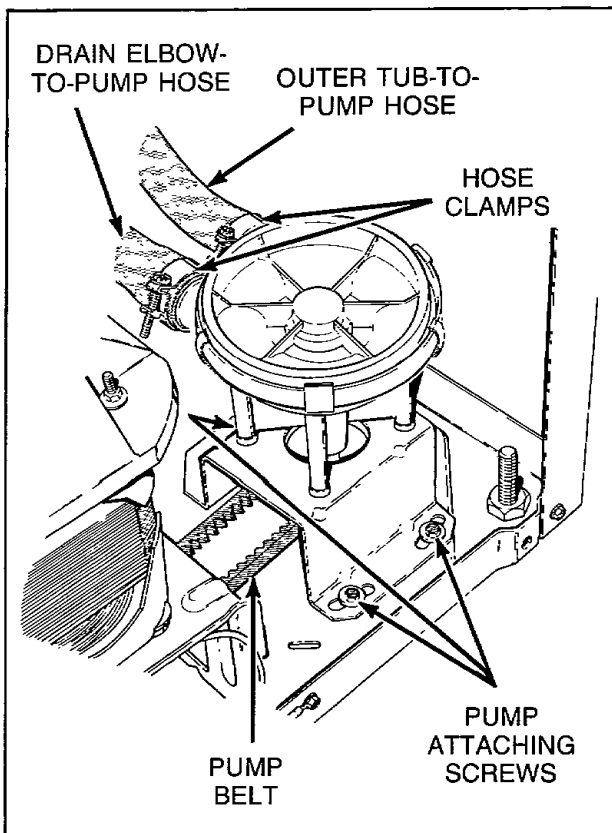

Figure 20

hose away from the outer tub before tightening the hose clamp. If this is not done, the hose could twist toward the outer tub resulting in the hose rubbing against the bottom edge of the outer tub.

## Pump Mounting Bracket

Remove four hex head screws holding pump to mounting bracket.

**NOTE:** Refer to *Figure 21* for pump and mounting bracket assembly sequence.

## 21. CABINET TOP ASSEMBLY

- a. Remove front panel, paragraph 13.
- b. Remove two cabinet top hold-down screws, *Figure 22*.
- c. Metered Models - Unlock and open meter case service door. Then remove two cap screws holding timer and bracket to cabinet bracket, *Figure 3*.
- d. If the area or space permits, tape loading door closed and lift cabinet top to a vertical position by hinging it on the rear hold-down bracket.

**NOTE:** Cabinet top is self supporting, or use a small chain to support the cabinet top, *Figure 23*.

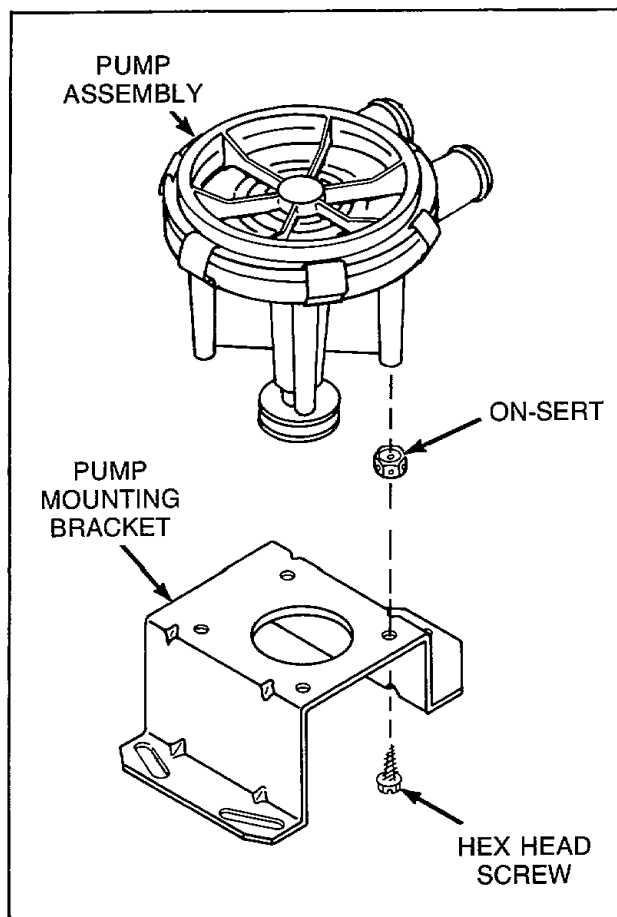

Figure 21

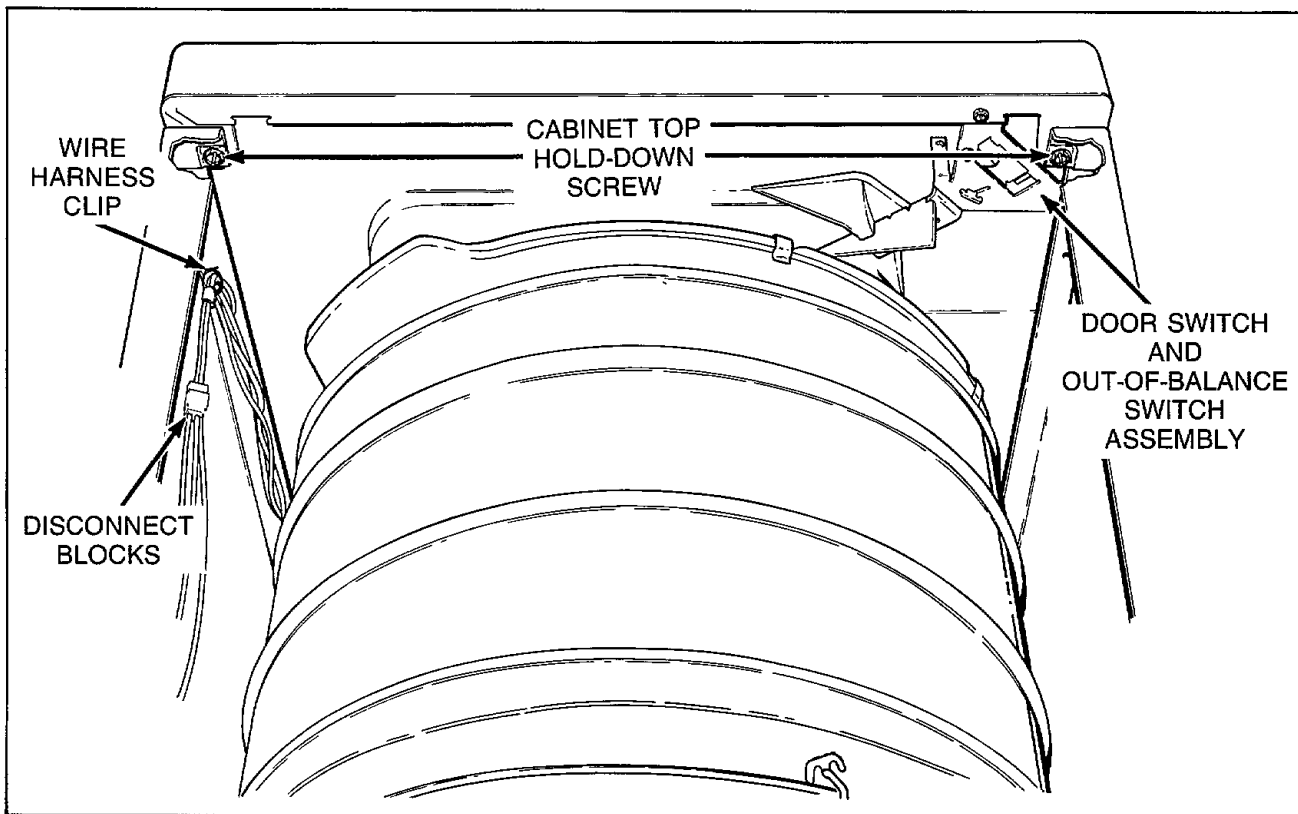

Figure 22

#### TO REMOVE CABINET TOP FROM WASHER

- a. Metered Models - Unlock and remove service door, then remove two cap screws holding timer and bracket to cabinet bracket, *Figure 3*.
- b. Remove front panel, paragraph 13.
- c. Remove two cabinet top hold-down screws, *Figure 22*.
- d. Remove two control panel attaching screws and lift assembly off panel support.
- e. Disconnect control hood harness from base wire harness at quick disconnect blocks.
- f. Disconnect pressure hose from pressure switch.

**IMPORTANT:** When installing pressure hose, blow air into hose before connecting hose to switch to remove any moisture that may have accumulated in the hose.

- g. Push base harness block, pressure hose and grommet down through hole in cabinet top.
- h. Tape loading door closed.
- i. Lift front of cabinet top slightly and pull forward to disengage from rear hold-down brackets and permit disconnecting green ground wire from top flange of washer cabinet.
- j. Carefully lift cabinet top off washer and set on protective padding.

**CAUTION:** Do not damage door switch and out-of-balance switch assembly when removing cabinet top.

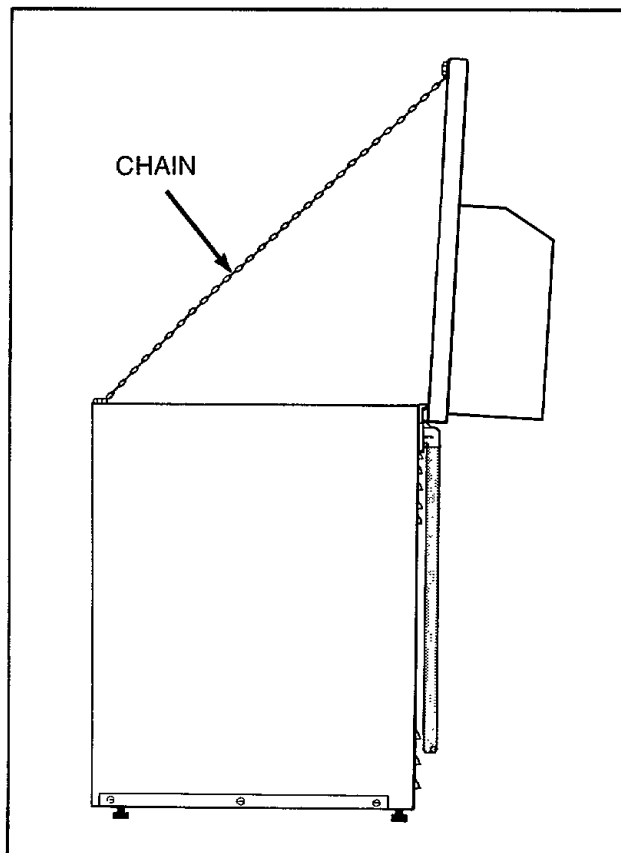

Figure 23



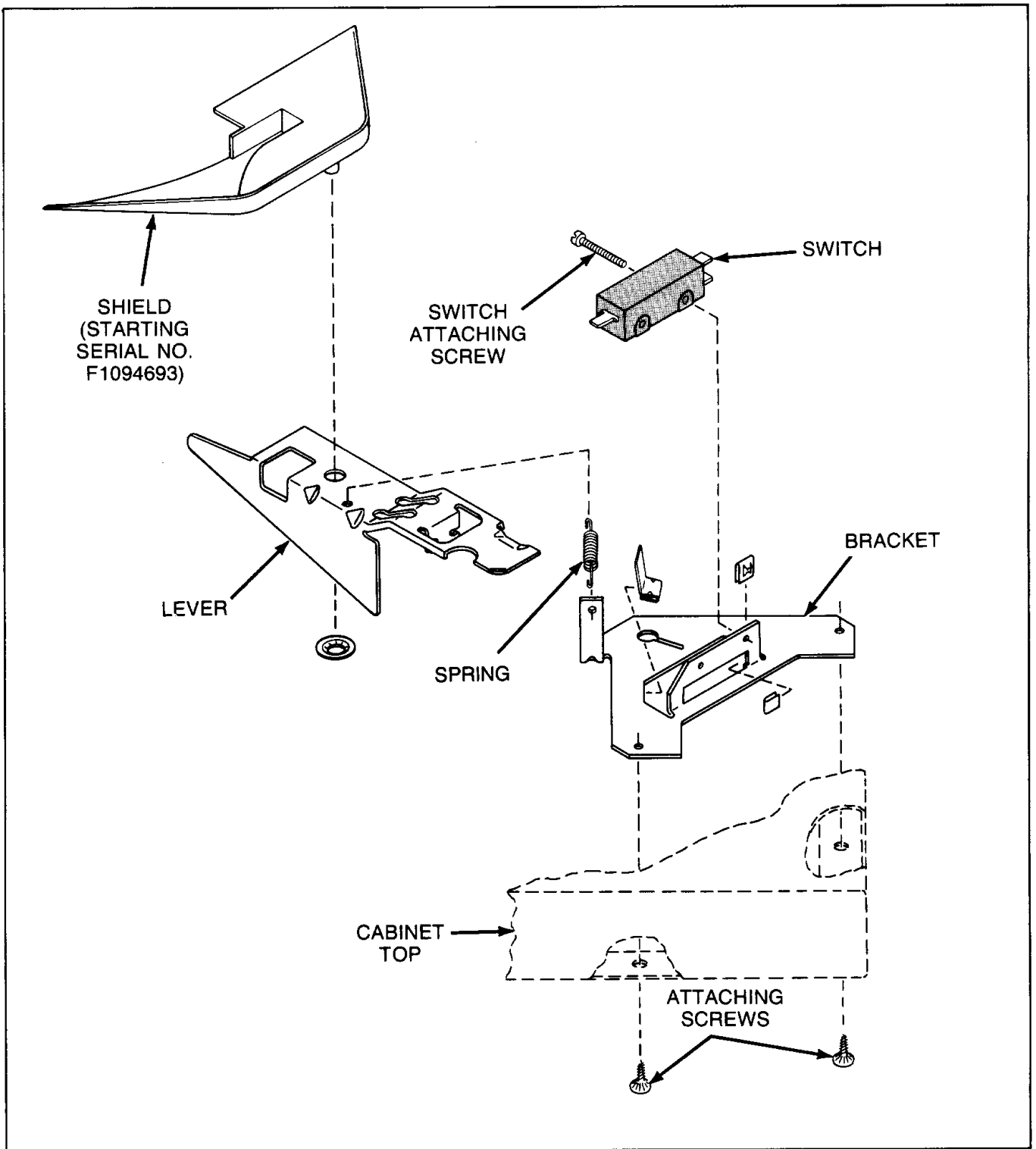

Figure 24

22. **DOOR AND OUT-OF-BALANCE SWITCH AND BRACKET ASSEMBLY** (Refer to Figure 24)

- a. Remove front panel, paragraph 13.
- b. Hinge cabinet top or remove, paragraph 21.
- c. Remove two screws holding switch and bracket assembly to underside of front flange of cabinet top.
- d. Disconnect wires from switch.

**NOTE:** Refer to appropriate wiring diagram when rewiring switch.

- e. Remove two screws holding switch to bracket.

**NOTE:** After installing switch and bracket assembly, adjust per paragraph 37.

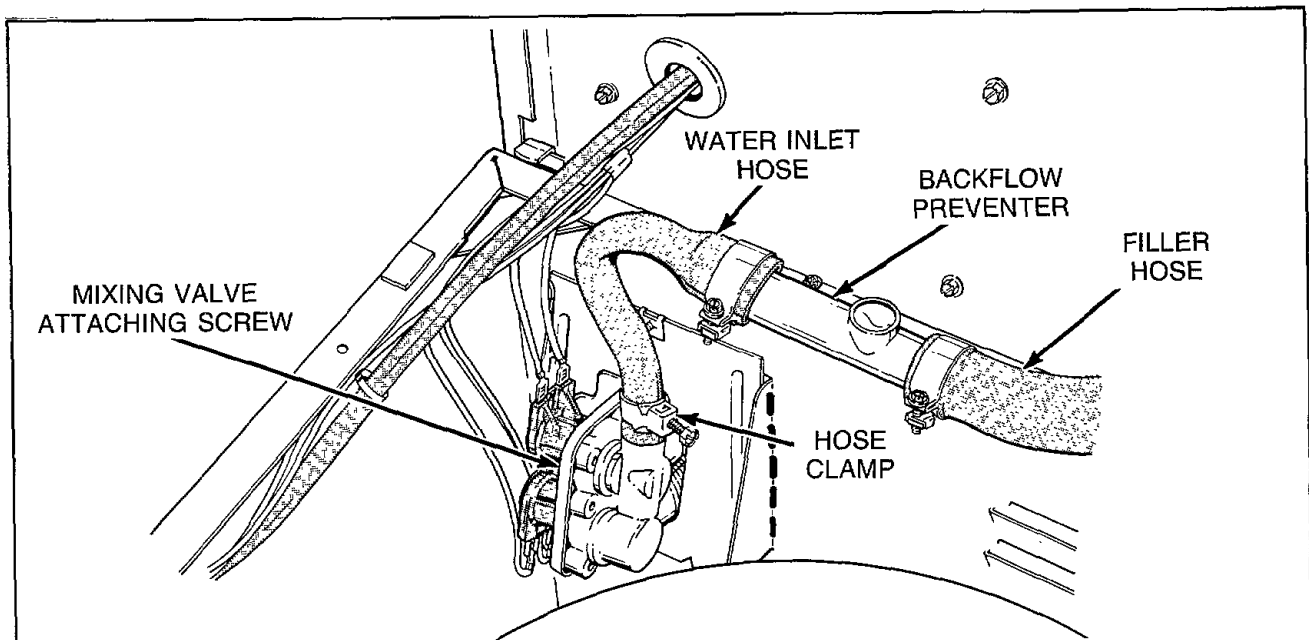

**Through Serial No. N1157099**

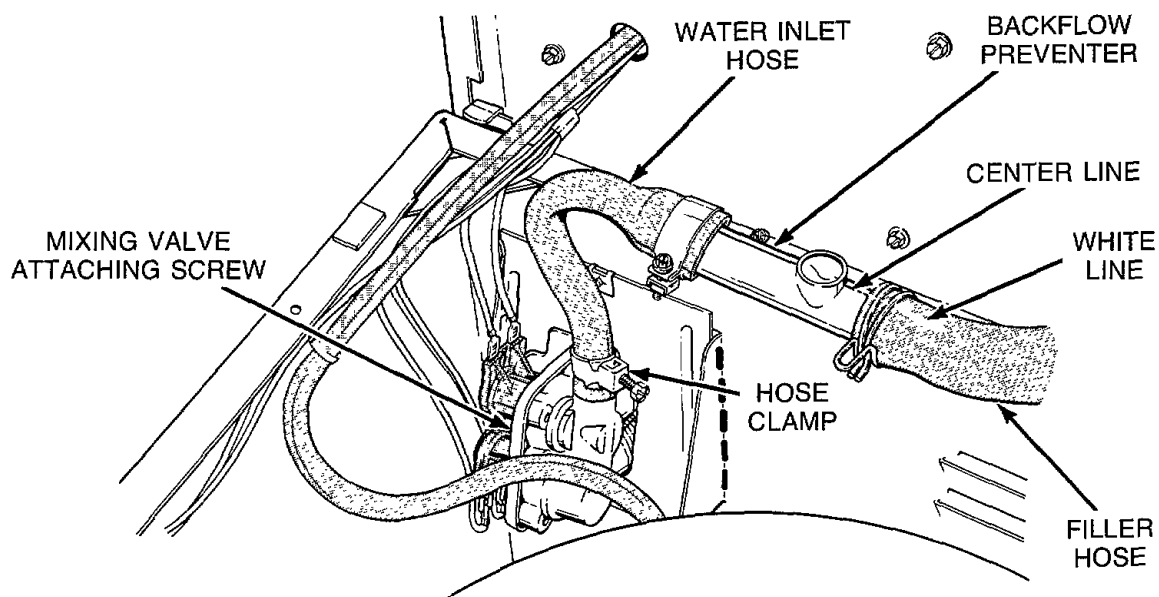

**Starting Serial No. N1157100**

Figure 25

**23. MIXING VALVE ASSEMBLY**

- a. Hinge cabinet top or remove, paragraph 17.
- b. Remove screw holding mixing valve to mounting bracket at rear of washer cabinet, *Figure 25*.

**NOTE:** When installing mixing valve, tab on bottom flange of mixing valve must be placed in positioning hole in mounting bracket.

- c. Pull mixing valve out toward front of washer far enough to permit disconnecting hoses from mixing valve, *Figure 25*.
- d. Disconnect wires from mixing valve solenoids.

**NOTE:** Refer to appropriate wiring diagram when rewiring solenoids.

## 24. WASHTUB AND CLOTHES GUARD OR LINT FILTER

- a. Remove agitator hold-down cap or load level indicator and lift agitator out of washtub.
- b. Hinge cabinet top or remove, paragraph 21.
- c. Disconnect filler hose from backflow preventer, *Figure 25*.

**NOTE:** (Starting with Serial No. N1157100), when installing filler hose, white line on hose must be aligned with centerline of backflow preventer, *Figure 25*.

- d. Remove the eight clips holding outer tub cover to tub, *Figure 26*, and lift cover off tub.

**NOTE:** When installing outer tub cover, always use a new cover gasket. Lubricate the gasket with rubber lube or liquid soap to aid in assembly. Cover must be placed on outer tub so notch on top edge of outer tub cover is directly over left front clip hole in tub, *Figure 26*. Starting with this hole, place each spring clip in its respective hole and snap in place. See *Figure 26* for proper clip installation.

- e. Remove four cap screws and washers holding washtub to hub, *Figure 27*.

**IMPORTANT:** Use caution when installing the cap screws to avoid chipping porcelain on the washtub.

- f. Lift washtub (with clothes guard or lint filter attached) out of outer tub.

**NOTE:** When installing washtub, use a new gasket between tub and hub. Be sure all traces of the old gasket are removed from underside of washtub and from hub.

- g. Remove the eight fasteners holding clothes guard or lint filter to washtub, *Figure 28*.

**NOTE:** When installing clothes guard or lint filter, it is necessary to start the first fastener in the round hole, *Figure 28*. Place the remaining fasteners in their respective holes.

## 25. WATER SEAL ASSEMBLY

### WARNING

If water is present in washtub, spin and pump out before removing agitator post.

- a. Remove front panel, paragraph 13.
- b. Remove two cabinet top hold-down screws and hinge cabinet top or remove from washer, paragraph 21.
- c. Remove agitator hold-down cap or load level indicator and lift agitator out of washtub.

- d. Disconnect filler hose from backflow preventer, then remove the eight clips holding cover to outer tub, *Figure 26*.

**NOTE:** (Starting with Serial No. N1157100), when reinstalling filler hose, white line on hose must be aligned with center line of backflow preventer, *Figure 25*.

- e. Lift cover off tub and remove old gasket.
- f. Remove the four cap screws holding washtub to hub, *Figure 27*, then lift washtub out of outer tub.

**NOTE:** Be sure all traces of old gasket are removed from bottom of washtub.

- g. Remove four cap screws holding agitator post assembly to hub, then lift assembly from hub.
- h. Straighten bent tab(s) on lockwasher, *Figure 29*, then remove hex nut using No. 237P4 Hex Wrench.
- i. Remove hub from splines on transmission tube.

**NOTE:** It may be necessary to use a gear puller with No. 230P4 Guide Tool to remove hub.

- j. Remove old seal from outer tub.

**IMPORTANT:** Use caution when removing old seal so as not to damage the tub flange or porcelain.

### TO INSTALL NO. 356P3 WASHER SEAL KIT

**IMPORTANT:** Be sure the inner surface of the tub flange is clean of all foreign material before installing the new seal.

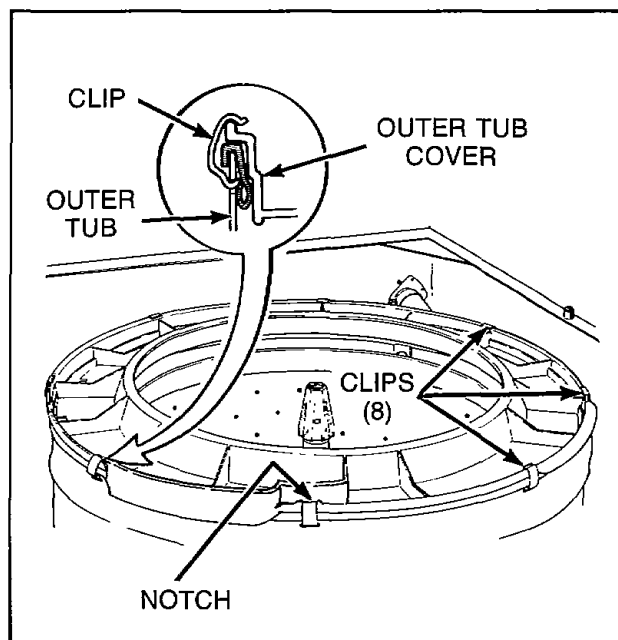

Figure 26

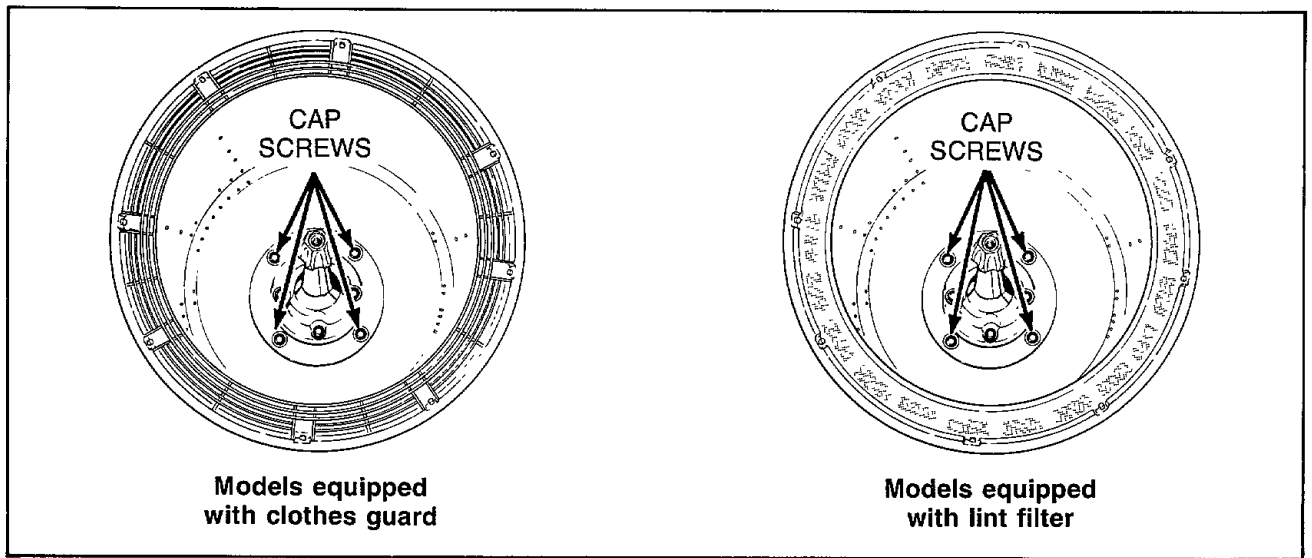

Figure 27

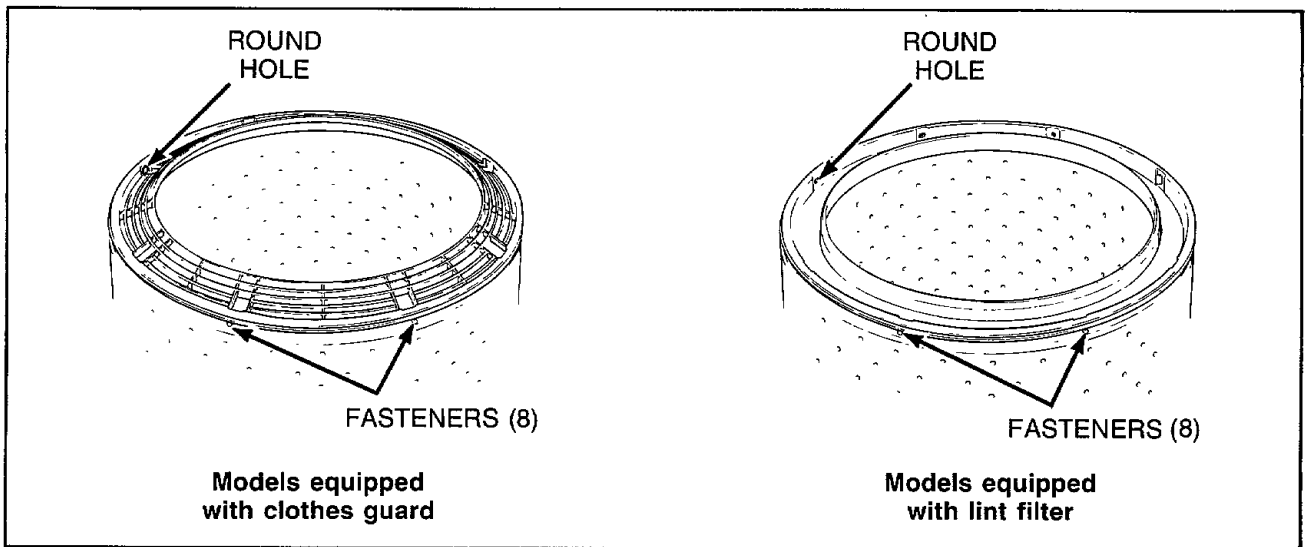

Figure 28

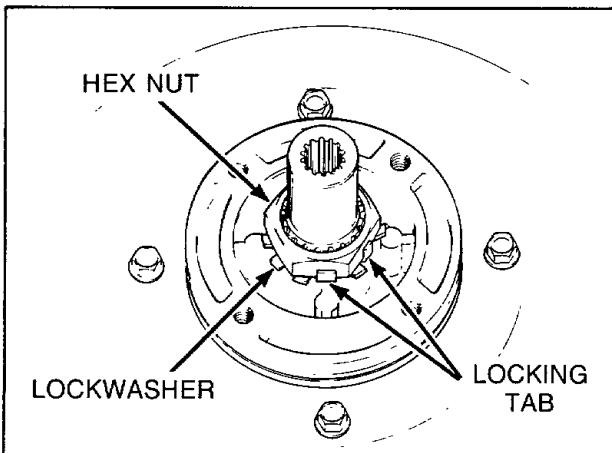

Figure 29

- a. Remove metal seal retainer ring (if present) from seal. Place new seal over outer tub flange (with seal lip on outside of tub flange). Then firmly press seal into flange opening using the small end of the No. 241P4 Seal Installer Tool (supplied in kit).

**NOTE:** Carefully place metal seal retainer ring (removed in step "a") over outer edge of seal lip, then carefully press retainer ring down over seal lip using the large end of the No. 241P4 Seal Installer Tool (supplied in kit).

- b. Apply a small amount of No. 27615 Sealant, (supplied in kit) around the outer edge of seal and tub. (The area located just below the metal seal retainer ring.)

(continued)

**WARNING**

**Do not allow sealant to get in contact with the sealing surface of the water seal!**

- c. Lubricate the inner splines of the new hub assembly (supplied in kit) with No. 27604P Anti-Seize compound.
- d. Apply a light film of a non-staining petroleum jelly (such as vaseline) to the bronze portion of water seal located in washtub, and to the outer surface of the stainless steel sleeve.

**WARNING**

**Do not over lubricate!**

- e. Place the stainless steel sleeve on the underside of hub, then carefully place new hub and seal assembly (supplied in kit) on splined transmission tube and install lockwasher and locknut.

**NOTE:** Locknut must be installed with beveled side down.

**IMPORTANT:** Torque locknut down between 40 to 70 foot pounds (54.23 to 94.91 N·m). If a torque wrench is not available, tap hex wrench with a hammer until hub turns or until nut will no longer tighten. After nut has been tightened, bend at least two locking tabs on lockwasher into place on hex nut, *Figure 29*.

- f. Apply a small amount of non-staining petroleum jelly (such as vaseline) to each of the sealing surfaces where washtub gasket will contact hub.
- g. Carefully place the new washtub gasket (supplied in kit) on hub.

**NOTE:** Be sure holes in gasket are aligned with bolt holes in hub.

- h. Apply a small amount of non-staining petroleum jelly (such as vaseline) to top surface of gasket where bottom of washtub will contact gasket.

**NOTE:** Be sure all traces of old gasket are removed from bottom of washtub.

- i. Install washtub by grasping underside of clothes guard or lint filter and carefully lower washtub down onto gasket and hub.

**IMPORTANT:** Before setting tub into place, be sure bolt holes in washtub line up with holes in gasket and hub.

- j. Secure washtub to hub using four cap screws previously removed.

**IMPORTANT:** Use caution when tightening cap screws to avoid chipping porcelain on the washtub.

**NOTE:** If Loctite was originally used between the agitator post and hub, then Loctite must be used again when replacing the agitator post. Be sure all traces of the old Loctite has been removed from the underside of the agitator post. Apply approximately a 1/16 inch diameter continuous bead of No. 28434P Loctite to the embossed surfaces of either the agitator post or hub. Then continue on with step "k".

If a gasket was originally used between agitator post and hub, then use the new gasket (supplied in kit) and install gasket and agitator post as follows:

1. Apply a small bead of Sealant, No. 27615, to each of the sealing surfaces where the agitator post gasket will contact the hub.
2. Carefully place the new agitator post gasket, No. 27020, (supplied in kit) on hub.

**NOTE:** Be sure holes in gasket are aligned with bolt holes in hub.

3. Apply 2 small beads of Sealant, No. 27615, to the top surface of gasket where bottom of agitator post casting will contact gasket.

**NOTE:** Be sure all traces of the old gasket are removed from the bottom of agitator post.

- k. Carefully lower agitator post assembly down onto gasket (if present) and hub.

**IMPORTANT:** Before setting post in place, make sure splines on bottom end of agitator drive shaft line up with splines in coupling on transmission, and holes in agitator post line up with the bolt holes in gasket (if present) and hub.

**NOTE:** It may require tapping lightly on drive block to force splines on drive shaft into the coupling on transmission assembly.

- l. Secure agitator post to hub using cap screws previously removed.
- m. Carefully place new outer tub cover gasket, No. 27184, (supplied in kit) around top rim of outer tub.

**NOTE:** When installing outer tub cover, lubricate the cover gasket with liquid soap to aid assembly. Cover must be placed on outer tub so notch on top edge of outer tub cover is directly over left front clip hole in tub, *Figure 26*. Starting with this hole, place each spring clip in its respective hole and snap into place.

- n. Reinstall filler hose on backflow preventer.

**NOTE:** (Starting with Serial No. N1157100), when

reinstalling filler hose, white line on hose must be aligned with center line of backflow preventer, *Figure 25*.

- o. Reinstall cabinet top and secure to washer cabinet using two screws previously removed.
- p. Reinstall front panel.
- q. Replace agitator and tighten agitator hold-down cap or load level indicator.
- r. Turn washer timer to the final spin, close loading door, start washer and let washtub spin for approximately 30 seconds to 1 minute.

**IMPORTANT:** This step is necessary to allow the petroleum jelly, applied in step "d", a chance to run in on the seal surfaces before water is added to the washer.

## 26 OUTER TUB

- a. Remove front panel, paragraph 13.
- b. Remove two cabinet top hold-down screws and hinge cabinet top or remove, paragraph 21.
- c. Remove agitator hold-down cap or load level indicator and lift agitator out of washtub.
- d. Loosen hose clamp and disconnect filler hose from backflow preventer, then remove the eight clips holding cover to the outer tub, *Figure 26*.

**NOTE:** (Starting with Serial No. N1157100), when reinstalling filler hose, white line on hose must be aligned with center line of backflow preventer, *Figure 25*.

- e. Remove cover from outer tub and set off to the side to avoid damage, then remove old gasket.

**NOTE:** When installing outer tub cover, always use a new cover gasket. Lubricate the gasket with liquid soap to aid in assembly. Cover must be placed on outer tub so notch on top edge of outer tub cover is directly over left front clip hole in tub, *Figure 26*. Starting with this hole, place each spring clip in its respective hole and snap in place. See *Figure 26* for proper clip installation.

- f. Remove four cap screws and washers holding washtub to hub, *Figure 27*.

**IMPORTANT:** Use caution when installing cap screws to avoid chipping porcelain on the washtub.

- g. Lift washtub (with clothes guard or lint filter attached) out of outer tub.

**NOTE:** Be sure all traces of old gasket are removed from bottom of washtub.

- h. Remove four cap screws holding agitator post to hub, *Figure 11*. Then remove assembly from hub.
- i. Straighten bent tab(s) on lockwasher, *Figure 29*,

then remove hex nut using No. 237P4 Hex Wrench.

- j. Remove hub from splines on transmission tube.

**NOTE:** It may be necessary to use a gear puller with No. 230P4 Guide Tool to remove hub.

- k. Remove old seal from outer tub.

**IMPORTANT:** Use caution when removing old seal so as not to damage the tub flange or porcelain.

**NOTE:** When reinstalling or replacing outer tub, always install a new No. 356P3 Washer Seal Kit, paragraph 25.

- l. Reach in through front of motor mounting bracket and move idler lever to the left to release tension on belt, *Figure 16*.

**IMPORTANT:** Use caution when releasing the idler lever tension. If the idler lever spring is overstretched, it will affect the washer operation.

- m. While holding idler lever, reach in and around right side of motor and run belt off right side of pulley, *Figure 16*.

**IMPORTANT:** When removing or reinstalling the complete outer tub into the washer (with transmission, balance ring and pivot dome attached), damage could occur to the idler lever if the idler spring is left hooked to the motor mounting bracket.

With the idler spring hooked to the motor mounting bracket, the idler lever extends out through the rear of the bracket. When removing or reinstalling the complete tub assembly, the idler lever is in the way and can be damaged (bent), or the idler pulley could be chipped. A bent idler lever will cause misalignment of the idler pulley with the drive belt, and a chipped idler pulley will damage the belt.

We recommend that before removing or reinstalling the complete assembly, you unhook the idler spring and move the idler lever out of the way. This will prevent the possibility of idler lever or pulley damage.

- n. Using the No. 229P4 Spring Hook Tool, unhook the five centering springs from lower edge of outer tub, *Figure 30*.

**IMPORTANT:** When removing centering springs, mark on side of outer tub what notch the spring was hooked into. Springs must be placed in the same notch when reinstalling. Do not overstretch springs.

(continued)

- o. Disconnect hoses between outer tub and pump assembly.
- p. (Starting with Serial No. L1168435), remove hose clamp holding pressure hose to pressure accumulator. Then remove tape holding pressure hose to outer tub.
- q. Grasp outer tub and lift complete tub assembly (with transmission, balance ring and pivot dome attached) straight up and out of washer cabinet.
- r. Turn the outer tub upside-down and set on protective padding.
- s. Remove screws and lockwashers holding each support leg to outer hub, *Figure 31*. Then lift transmission, balance ring and pivot dome off tub.

**NOTE:** To prevent porcelain damage, leg plates must be installed on both sides of the outer tub flange when reinstalling support legs. (The thinner plate must be installed between leg and tub flange and the thicker plate must be installed on the outside of tub flange.) Do not overtighten the screws as this could cause stripping or porcelain damage.

- t. (Starting with Serial No. L1168435), turn outer tub upright and remove the pressure accumulator and grommet.

**NOTE:** When installing the grommet into the outer tub, the thicker lip of the grommet must be installed to the outside of the tub. Lubricate the outer surface of the large opening of the

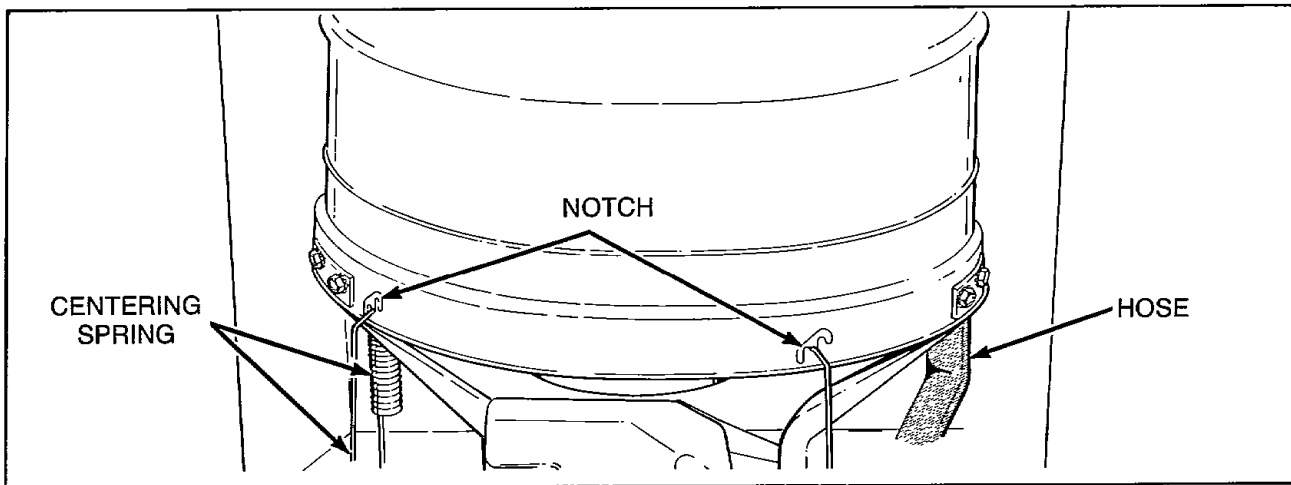

Figure 30

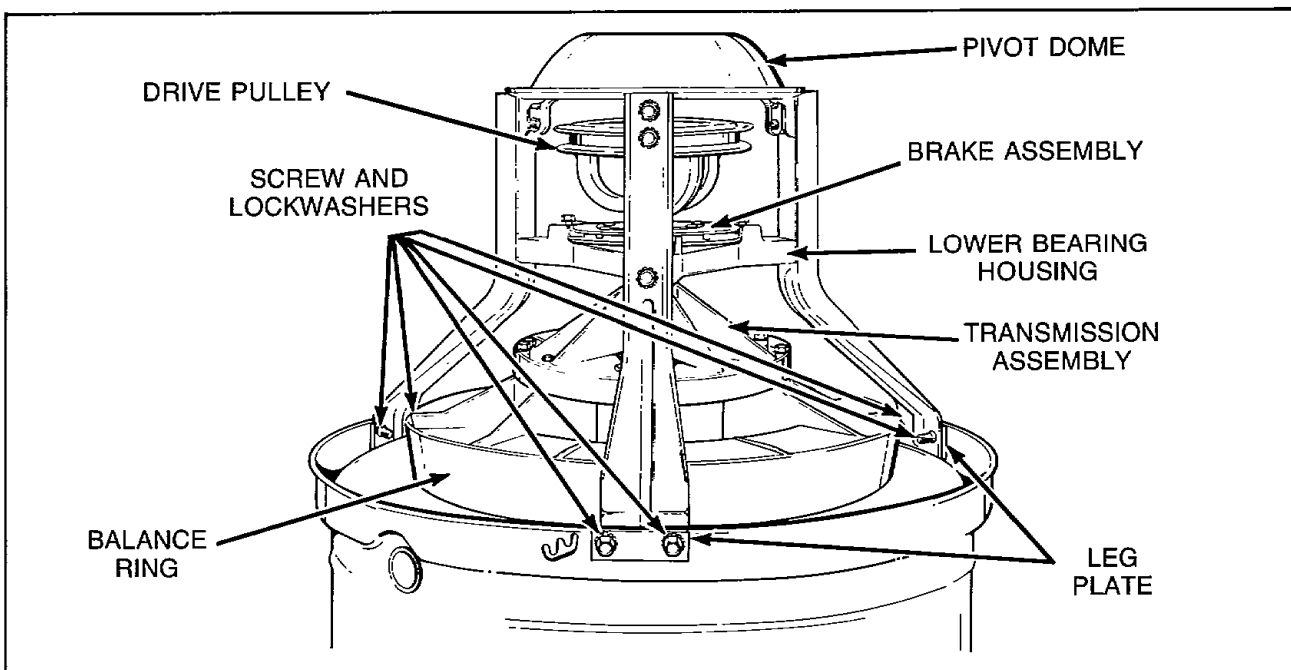

Figure 31

accumulator with liquid soap to aid in assembling accumulator into the grommet.

## 27. DRIVE PULLEY AND HELIX

- a. Remove two screws from bottom edge of front panel, *Figure 14*.
- b. Pull bottom of panel away from washer until hold-down clips (located on top flange of panel) disengage from slots in cabinet top.
- c. Remove two front mounting screws and loosen the rear mounting screw holding pump and bracket to washer base, *Figure 20*. Pivot entire pump assembly toward motor to loosen belt tension.
- d. Run belt off motor pulley, then remove belt from pump pulley.

**NOTE:** After installing belt, adjust belt, paragraph 36.

- e. Reach in through front of motor mounting bracket and move idler lever to the left to release tension on belt, *Figure 16*.

**IMPORTANT:** Use caution when releasing the idler lever tension. If the idler spring is overstretched, it will affect the washer operation.

- f. While holding idler lever, reach in and around right side of motor and run belt off right side of large drive pulley, *Figure 16*.
- g. Remove belt from motor pulley and pull belt out through front of motor mounting bracket.

**NOTE:** When reinstalling belt, there is no drive belt adjustment, refer to paragraph 35.

- h. Disconnect motor wire harness from base wire harness at disconnect blocks, *Figure 22*.
- i. Remove screw holding ground wire to washer base, *Figure 17*.
- j. Remove four screws holding motor and mounting bracket to washer base, *Figure 17*, then lift complete assembly out of washer.

**NOTE:** When reinstalling motor and mounting bracket, tab on right side of mounting bracket must be placed in positioning hole in base. Mounting bracket must be shifted toward rear of washer to its limit of travel within the mounting bracket attaching screws.

- k. Remove cap screw, washer and helix from bottom of input shaft of transmission assembly, *Figure 32*.
- l. Remove drive pulley by tilting right side up and slide pulley out between right front and rear tub support legs.

**IMPORTANT:** When reassembling, large flat washer, bearing race, needle bearing and bearing race must be in place, see *Figure 33* for assembly sequence.

**NOTE:** When reassembling, lubricate the needle bearing with No. 21814 Lubricant and the helix ramps with No. 03200 Lubricant.

## 28. BRAKE ASSEMBLY

- a. Remove drive pulley and helix, paragraph 27.
- b. Using a right angle needle nose pliers, remove spring from around lower transmission tube (located inside brake assembly).

**NOTE:** Remove spring by turning in a counter-clockwise direction (looking from lower end of input shaft of transmission assembly).

- c. Remove three shoulder screws holding brake pads, rubber sleeves and brake assembly to lower bearing housing, *Figure 33*, then remove brake assembly, pads and spacer off bottom of transmission assembly.

**IMPORTANT:** When reinstalling new brake assembly, we recommend replacing the three brake pads. DO NOT replace just the worn pads.

**NOTE:** Refer to *Figure 33* for assembly sequence.

**IMPORTANT:** When installing spring, be sure it is inserted into groove in large splines of lower transmission tube. Use tool, Part No. 242P4, when installing spring.

## 29. LOWER BEARING HOUSING

- a. Remove two screws from bottom edge of front panel, *Figure 14*.
- b. Pull bottom of panel away from washer until hold-down clips (located on top flange of panel) disengage from slots in cabinet top.
- c. Remove two cabinet top hold-down screws and hinge cabinet top or remove, paragraph 21.
- d. Remove agitator hold-down cap or load level indicator and lift agitator out of washtub.
- e. Disconnect filler hose from backflow preventer, *Figure 25*.

**NOTE:** (Starting with Serial No. N1157100), when reinstalling filler hose, white line on hose must be aligned with center line of backflow preventer, *Figure 25*.

- f. Reach in through front of motor mounting bracket and move idler lever to the left to release tension on belt, *Figure 16*.

**IMPORTANT:** Use caution when releasing the idler lever tension. If the idler spring is overstretched, it will affect the washer operation.

- g. While holding idler lever, reach around right side of motor and run belt off right side of large drive pulley, *Figure 16*.
- h. Pull belt out toward front of washer.

(continued)



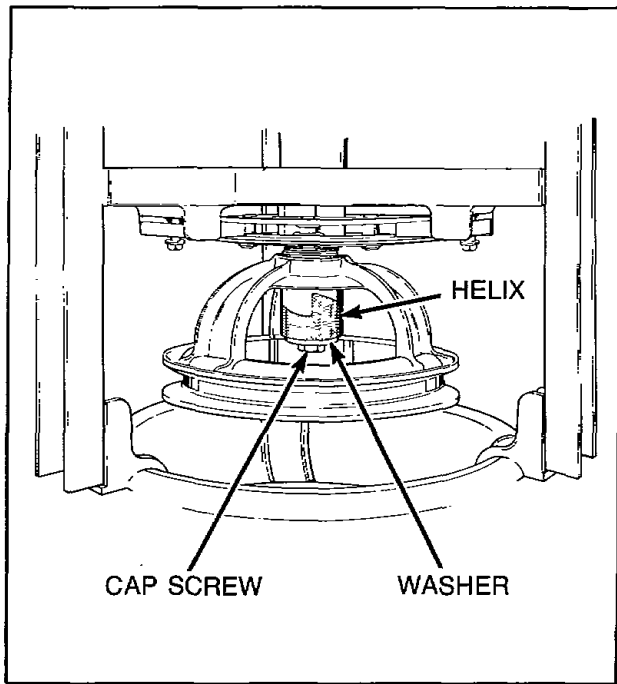

Figure 32

**IMPORTANT:** When removing or reinstalling the complete outer tub into the washer (with washtub, transmission, balance ring and pivot dome attached), damage could occur to the idler lever if the idler spring is left hooked to the motor mounting bracket.

With the idler spring hooked to the motor mounting bracket, the idler lever extends out through the rear of the bracket. When removing or reinstalling the complete tub assembly, the idler lever is in the way and can be damaged (bent), or the idler pulley could be chipped. A bent idler lever will cause misalignment of the idler pulley with the drive belt, and a chipped idler pulley will damage the belt.

We recommend that before removing or reinstalling the complete assembly, you unhook the idler spring and move the idler lever out of the way. This will prevent the possibility of idler lever or pulley damage.

- i. Using the No. 229P4 Spring Hook Tool, unhook the five centering springs from the lower edge of outer tub, *Figure 30*.

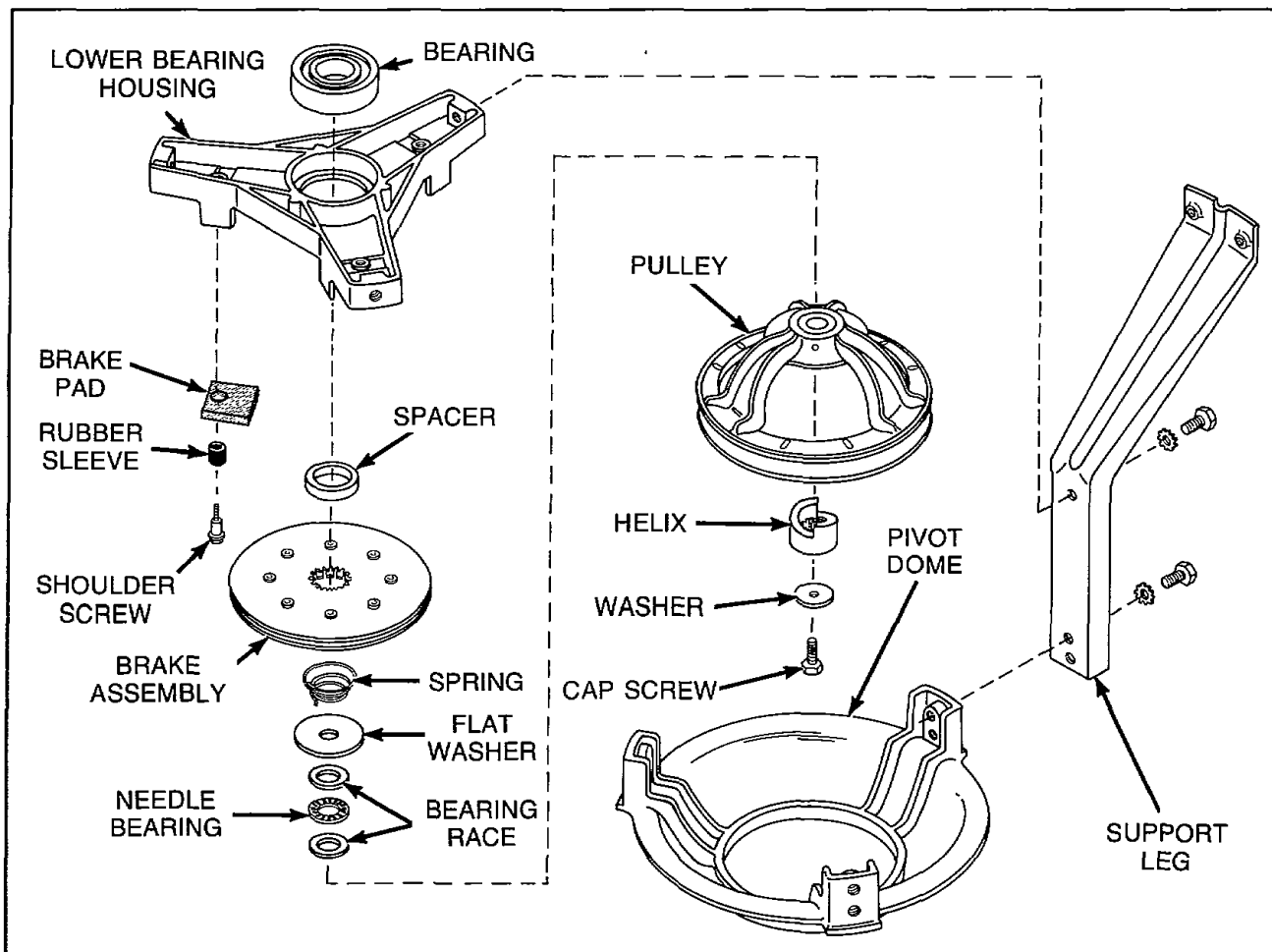

Figure 33

**IMPORTANT:** When removing the centering springs, mark on side of outer tub what notch the spring was hooked into. Springs must be placed in the same notch when reinstalling. Do not overstretch springs.

- j. Disconnect hoses between outer tub and pump assembly.

**CAUTION:** There will always be some water that will remain in the outer tub, therefore, before removing the hoses from the pump, the hoses will have to be drained to prevent spillage on the floor.

- k. (Starting with Serial No. L1168435), remove hose clamp holding pressure hose to pressure accumulator and remove hose.
- l. Grasp outer tub and lift tub (with washtub, transmission, balance ring and pivot dome attached) straight up and out of washer cabinet.
- m. Turn complete tub assembly upside-down on protective padding.

**CAUTION:** When turning the complete tub assembly upside-down, be careful not to damage the out-of-balance switch trigger (located on outer tub cover).

- n. Remove cap screw, washer and helix holding drive pulley to transmission shaft, *Figure 32*.
- o. Remove drive pulley from transmission shaft, *Figure 33*.
- p. Remove needle bearing, bearing races and large flat washer from transmission shaft, *Figure 33*.
- q. Use a right angle needle nose pliers and remove spring from around lower transmission tube (located inside brake assembly).

**NOTE:** Remove spring by turning in a counter-clockwise direction (looking at bottom end of shaft).

**IMPORTANT:** When installing spring, be sure it is inserted into groove in large splines of lower transmission tube. Use spring tool, No. 242P4, when installing spring.

- r. Remove three shoulder screws and rubber sleeves holding brake pads to lower bearing housing, *Figure 33*.
- s. Lift brake assembly, pads and spacer off transmission tube.
- t. Remove three cap screws and lockwashers holding lower bearing housing to tub support legs, *Figure 33*.
- u. Rotate bearing housing past legs, then carefully lift bearing housing off transmission tube.

**NOTE:** It may be necessary to loosen one leg from pivot dome to rotate housing. It may require tapping lightly on housing to loosen it from the transmission tube.

**IMPORTANT:** When installing the lower bearing housing, apply No. 27604P Anti-Seize compound to the area of the transmission tube that will be contacting the bearing.

## TO REMOVE BEARING

- a. Support the bearing housing around the outside diameter of the bearing opening and carefully press the bearing out of the housing.
- b. Clean all foreign material from inside diameter of the bearing opening.
- c. Clean any foreign material from the outside diameter of the new bearing.
- d. Apply a retaining compound (such as Loctite®) to the outside diameter of the new bearing and carefully press new bearing into housing (with sealed side facing up).

**IMPORTANT:** Press new bearing into housing by pressing on the outer race of the bearing only, and press until bearing bottoms out in housing.

## 30. TRANSMISSION ASSEMBLY

- a. Remove two screws from bottom edge of front panel, *Figure 14*.
- b. Pull bottom of panel away from washer until hold-down clips (located on top flange of panel) disengage from slots in cabinet top, *Figure 14*.
- c. Remove two cabinet top hold-down screws, *Figure 22*, and hinge cabinet top or remove, paragraph 21.
- d. Remove agitator hold-down cap and lift agitator out of washtub.
- e. Loosen hose clamp and disconnect filler hose from backflow preventer, *Figure 25*. Then remove the eight clips holding cover to outer tub, *Figure 26*.

**NOTE:** (Starting with Serial No. N1157100), when reinstalling filler hose, white line on hose must be aligned with center line of backflow preventer, *Figure 25*.

- f. Remove cover from outer tub and set off to the side to avoid damage, then remove old gasket.

**NOTE:** When reinstalling outer tub cover, always use a new cover gasket. Lubricate the gasket with liquid soap to aid in assembly. Cover must be placed on outer tub so notch on top edge of outer tub cover is directly over left front clip hole in tub, *Figure 26*. Starting with this hole, place each spring clip in its respective hole and snap into place. See *Figure 26* for proper clip installation.

- g. Remove four cap screws and washers holding washtub to hub, *Figure 27*.

**IMPORTANT:** Use caution when installing cap screws to avoid chipping porcelain on the washtub.

(continued)

- h. Lift washtub (with clothes guard or lint filter attached) out of outer tub.

**NOTE:** Be sure all traces of old gasket are removed from bottom of washtub.

- i. Remove four cap screws holding agitator post to hub, *Figure 11*, and remove assembly from hub.
- j. Straighten bent tab(s) on lockwasher, *Figure 29*, then remove hex nut using No. 237P4 Hex Wrench.
- k. Remove hub from splines on transmission tube.

**NOTE:** It may be necessary to use a gear puller with No. 230P4 Guide Tool to remove hub.

- l. Remove old seal from outer tub.

**IMPORTANT:** Use caution when removing old seal so as not to damage the tub flange or porcelain.

**NOTE:** When reinstalling or replacing the outer tub, we recommend installing a new No. 356P3 Washer Seal Kit, paragraph 25.

- m. Reach in through front of motor mounting bracket and move idler lever to the left to release tension on belt, *Figure 16*.

**IMPORTANT:** Use caution when releasing the idler lever tension. If the idler spring is overstretched, it will affect the washer operation.

- n. While holding idler lever, reach in and around right side of motor and run belt off right side of large drive pulley, *Figure 16*.

**IMPORTANT:** When removing or reinstalling the complete outer tub into the washer (with transmission, balance ring and pivot dome attached), damage could occur to the idler lever if the idler spring is left hooked to the motor mounting bracket.

With the idler spring hooked to the motor mounting bracket, the idler lever extends out through the rear of the bracket. When removing or reinstalling the complete tub assembly, the idler lever is in the way and can be damaged (bent), or the idler pulley could be chipped. A bent idler lever will cause misalignment of the idler pulley with the drive belt, and a chipped pulley will damage the belt.

We recommend that before removing or reinstalling the complete assembly, you unhook the idler spring and move the idler lever out of the way. This will prevent the possibility of idler lever or pulley damage.

- o. Using the No. 229P4 Spring Hook Tool, unhook the five centering springs from lower

edge of outer tub, *Figure 30*.

**IMPORTANT:** When removing the centering springs, mark on side of outer tub what notch the spring was hooked into. Springs must be placed in same notch when reinstalling. Do not overstretch springs.

- p. Disconnect hoses between outer tub and pump assembly.

**CAUTION:** There will always be some water that will remain in the outer tub, therefore, before removing hoses from the pump, the hoses will have to be drained to prevent water spillage on the floor.

- q. (Starting with Serial No. L1168435), loosen hose clamp holding pressure hose to pressure accumulator and remove hose. Then remove tape holding pressure hose to outer tub.
- r. Grasp outer tub and lift complete tub assembly (with transmission, balance ring and pivot dome attached) straight up and out of washer cabinet.
- s. Turn the outer tub upside-down and set on protective padding.
- t. Remove cap screw, washer and helix holding drive pulley to transmission shaft. Then remove drive pulley, needle bearing, bearing races and large flat washer from transmission.
- u. Using a right angle needle nose pliers, remove spring from around lower transmission tube (located inside brake assembly).

**NOTE:** Remove spring by turning in a counter-clockwise direction (looking at bottom end of shaft).

**IMPORTANT:** When reinstalling spring, be sure it is inserted into groove in large spline of transmission tube. Use spring tool, No. 242P4, when installing spring.

- v. Remove screws and lockwashers holding each support leg to outer tub, *Figure 31*, then lift pivot dome, brake assembly and lower bearing housing off transmission tube.

**NOTE:** It may be necessary to tap lightly on bearing housing to loosen it from the transmission tube.

**IMPORTANT:** To prevent porcelain damage, leg plates must be installed on both sides of the outer tub flange when reinstalling support legs. (The thinner plate must be installed between leg and tub flange and the thicker plate must be installed on the outside of tub flange.) Do not overtighten the screws as this could cause stripping or porcelain damage.

- w. Remove four cap screws and lockwashers holding transmission assembly to balance ring.

- x. Lift transmission assembly straight up and out of balance ring and upper bearing.

**IMPORTANT:** When installing the transmission assembly, apply No. 27604P Anti-Seize compound to the area of both transmission tubes where they will be contacting the upper and lower bearings. There is a mark located on the outer edge of the balance ring. This mark indicates the heavy side of the balance ring. This heavy side must be installed opposite the rack area of the transmission assembly. Carefully lower transmission through balance ring and upper bearing. **DO NOT DROP OR LOWER TRANSMISSION ASSEMBLY INTO POSITION TOO HARD** as this can cause the bearing to move within the bearing housing which will cause vibration, noise, wear or no spin.

### 31. BALANCE RING

- a. Remove transmission assembly, paragraph 30.
- b. Lift balance ring off outer tub.

### 32. UPPER BEARING ASSEMBLY

- a. Remove transmission assembly, paragraph 30, steps "a" through "s".

- b. Remove screws and lockwashers holding each support leg to outer tub, *Figure 31*. Lift complete pivot dome (with drive pulley, brake assembly, lower bearing housing, transmission assembly and balance ring attached) off outer tub.

**IMPORTANT:** To prevent porcelain damage, leg plates must be installed on both sides of the outer tub flange when reinstalling support legs. (The thinner plate must be installed between leg and tub flange and the thicker plate must be installed on the outside of tub flange.) Do not overtighten the screws as this could cause stripping or porcelain damage.

- c. Remove three cap screws holding upper bearing and housing to bottom of outer tub, *Figure 34*.

**NOTE:** Replace bearing and housing as an assembly, and be sure flinger is properly positioned between the outer tub and bearing assembly, *Figure 34*.

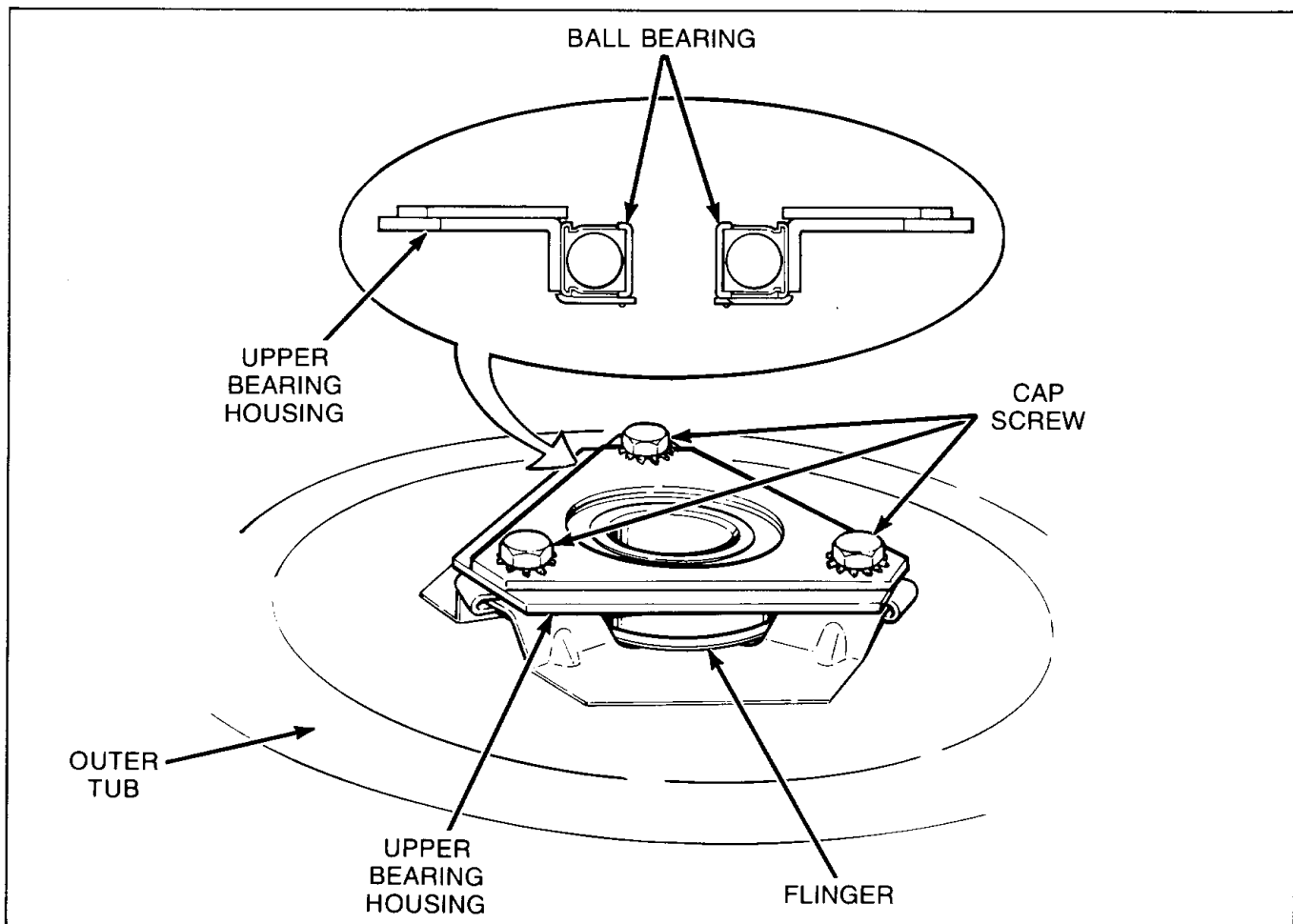

Figure 34

# SECTION III

## Adjustments

### 33. LEVELING LEGS (Refer to Figure 35)

- Loosen locknuts and thread leveling legs into washer base as far as possible.
- Turn appropriate leveling leg(s) out of base only until washer is level. Keep washer as close to floor as possible.
- Install rubber pads over leveling legs.

**IMPORTANT:** All four legs must rest firmly on floor as weight of washer is evenly distributed. Washer must not rock.

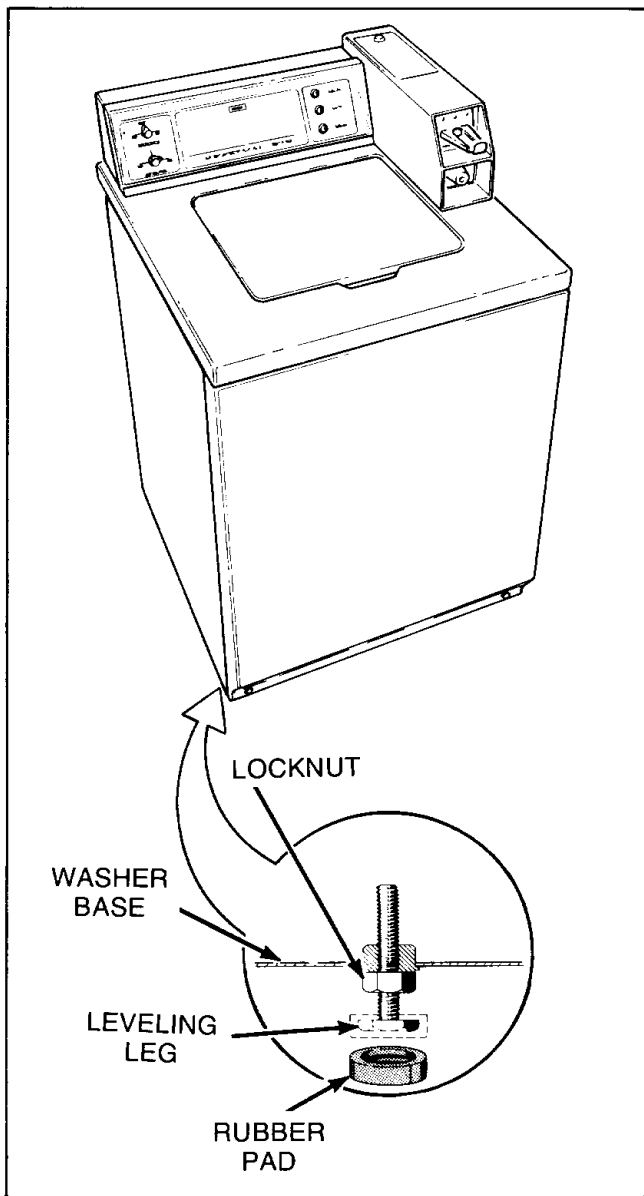

Figure 35

- Tighten locknuts securely against bottom of washer base.

**IMPORTANT:** DO NOT move washer at any time unless locknuts are securely tightened and the styrofoam shipping brace is in place over the agitator (to prevent damage to washer components). DO NOT slide washer across floor once the leveling legs have been extended, as legs and base could become damaged.

### 34. PRESSURE SWITCH (Refer to Figure 36)

**NOTE: DO NOT ADJUST PRESSURE SWITCH IF WASHER IS WITHIN THE WARRANTY PERIOD.**

The pressure switch on pressure-fill automatic washers is set at the factory for proper water fill levels. However, if there is a problem of overfilling or underfilling, the pressure switch can be adjusted in the field.

The maximum water fill level can be increased by turning adjusting screw clockwise, and decreased by turning screw counterclockwise. 1/4 turn of adjusting screw represents approximately one inch (2.54 cm) increase or decrease of water level in tub.

**IMPORTANT:** DO NOT turn adjusting screw more than 3/4 of a turn in either direction.

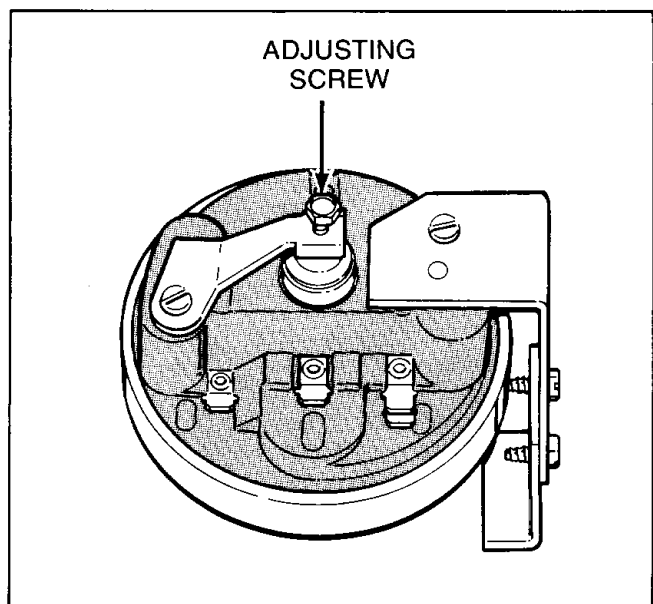

Figure 36

### 35. BELT - Agitate and Spin

No belt adjustment is required.

**NOTE:** When motor is installed in washer, motor and mounting bracket must be shifted toward rear of washer to its limit of travel within the mounting bracket attaching screws.

### 36. BELT - Pump

**NOTE:** Adjustment must be made after motor has been properly positioned, see paragraph 35.

- Remove front panel, paragraph 13.
- Loosen the two front mounting screws, *Figure 37*, then loosen the rear screw.
- Shift front of pump mounting bracket to the right or left to obtain proper belt tension. Proper tension is when belt can be deflected approximately 1/2 inch (12.7 mm) from its normal position by applying moderate pressure (1-1/2 pounds - .675 kg.) to a point midway between pulleys, *Figure 38*.
- After belt tension is obtained, tighten the three pump mounting bracket screws.

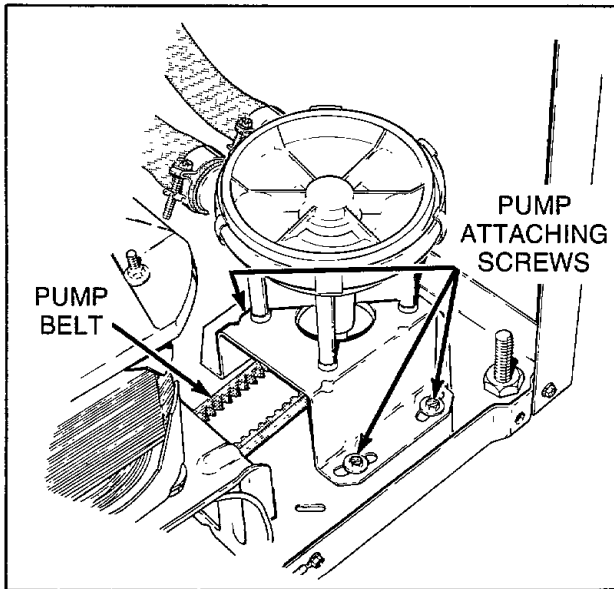

Figure 37

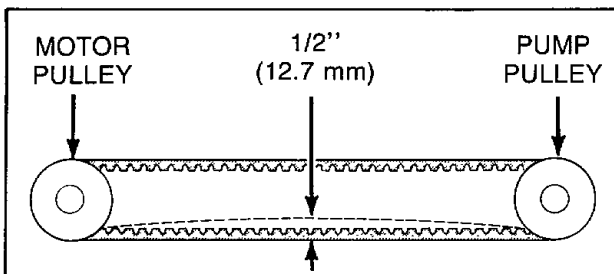

Figure 38

### 37. OUT-OF-BALANCE SWITCH TRIGGER

**NOTE:** The trigger is centered, *Figure 39*, on the mounting screw at the factory.

- Remove front panel, paragraph 13.
- Raise or remove cabinet top, paragraph 21.
- Loosen screw holding trigger to tub cover, *Figure 39*, move trigger to the right (increases sensitivity) or to the left (decreases sensitivity).

**IMPORTANT:** If the trigger repeatedly trips the out-of-balance switch lever, check the centering of the agitator within the loading door opening. At the factory the centering springs are positioned in the center notch, *Figure 40*. Centering springs may have to be moved to the upper or lower notch to center the agitator within the door opening.

**Example:** If the springs are placed in the upper notch, then the trigger must be moved to the extreme right for proper trigger operation.

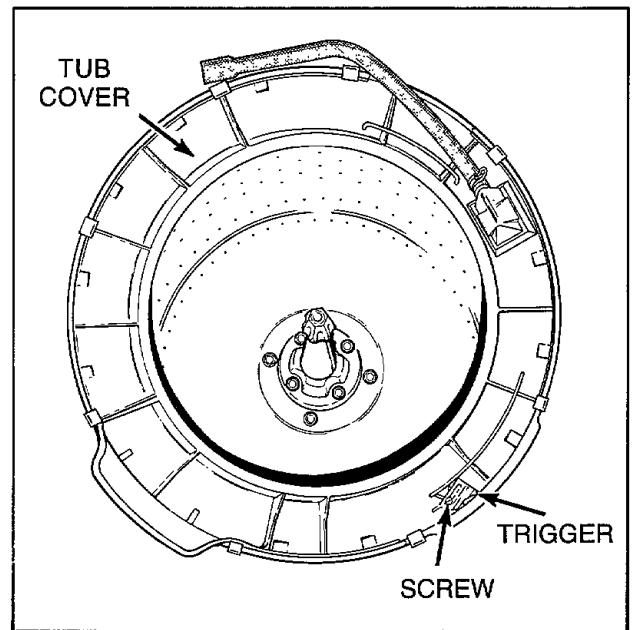

Figure 39

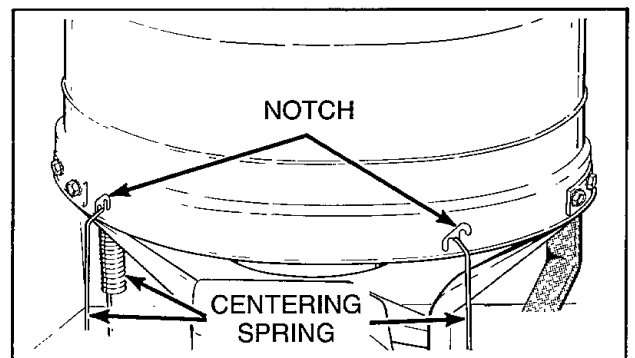

Figure 40

# SECTION IV

## Service Helps

**IMPORTANT**

Refer to appropriate Wiring Diagram for aid in testing washer components.

### 38. NO HOT WATER

POSSIBLE CAUSE	TO CORRECT
Hot water supply valve is closed.	Open valve.
Water supply is cold.	Check water heater.
Kinked hot water inlet hose.	Straighten or replace hose.
Clogged mixing valve screen, or clogged screen in outer end of inlet hose nearest water supply valve.	Disconnect hot water inlet hose, and clean or replace screen(s).
Inoperative hot water mixing valve solenoid.	Test solenoid and replace if inoperative.
Inoperative timer.	Test timer and replace if inoperative.
Inoperative temperature switch.	Test switch and replace if inoperative.
Inoperative pressure switch.	Test switch and replace if inoperative.
Clogged pressure hose.	Remove and clean hose.
Broken, loose, or incorrect wiring.	Refer to appropriate Wiring Diagram.

### 39. NO COLD WATER

POSSIBLE CAUSE	TO CORRECT
Cold water supply valve is closed.	Open valve.
Kinked cold water inlet hose.	Straighten or replace hose.
Clogged mixing valve screen, or clogged screen in outer end of inlet hose nearest water supply valve.	Disconnect cold water inlet hose, and clean or replace screen(s).
Inoperative cold water mixing valve solenoid.	Test solenoid and replace if inoperative.
Inoperative timer.	Test timer and replace if inoperative.
Inoperative temperature switch.	Test switch and replace if inoperative.
Inoperative pressure switch.	Test switch and replace if inoperative.
Clogged pressure hose.	Remove and clean hose.
Broken, loose, or incorrect wiring.	Refer to appropriate Wiring Diagram.

**40. NO WARM WATER**

<b>POSSIBLE CAUSE</b>	<b>TO CORRECT</b>
No hot water.	Refer to paragraph 38.
No cold water.	Refer to paragraph 39.

**41. WATER FILL DOES NOT STOP AT PROPER LEVEL**

<b>POSSIBLE CAUSE</b>	<b>TO CORRECT</b>
Inoperative pressure switch.	Test switch and replace if inoperative.
Air leak in pressure hose.	Replace hose.
Sediment on or under mixing valve diaphragm, defective diaphragm, or armature binding in armature guide.	Disassemble and clean mixing valve. Replace deteriorated or not easily cleaned components. Refer to Parts Section in this manual for assembly sequence of valve.
Broken, weak, or missing mixing valve armature spring.	Disassemble valve and replace spring. Refer to Parts Section in this manual for assembly sequence of valve.
A siphoning action started in washer which will cause water to be siphoned from the washer during the cycle due to the end of the drain hose being lower than drain elbow at rear of washer.	Install No. 297P3 Siphon Break Kit.
Water in pressure hose.	Blow air through hose to remove water.
Broken, loose, shorted or incorrect wiring.	Refer to appropriate Wiring Diagram.

**42. TIMER DOES NOT ADVANCE**

<b>POSSIBLE CAUSE</b>	<b>TO CORRECT</b>
Timer is designed to pause during fill periods.	Allow completion of fill period.
Inoperative timer.	Test timer, and replace if inoperative.
Loading door is open.	Close loading door.
Washer will not fill.	Timer pauses until water level switch is satisfied.
Timer motor lead wire(s) off timer terminals.	Refer to appropriate Wiring Diagram and reattach wire(s).
Broken, loose, or incorrect wiring.	Refer to appropriate Wiring Diagram.



#### 43. NO AGITATION

POSSIBLE CAUSE	TO CORRECT
Inoperative timer.	Test timer, and replace if inoperative.
Inoperative action switch.	Test switch and replace if inoperative.
Inoperative motor.	Test motor and replace if inoperative.
Inoperative pressure switch.	Test switch and replace if inoperative.
Broken, loose, or incorrect wiring.	Refer to appropriate Wiring Diagram.
Loose or broken drive belt.	Adjust or replace belt.
Inoperative transmission assembly.	Replace transmission assembly.
Sheared motor pulley roll pin.	Remove drive motor, and replace roll pin and any other damaged parts.
Drive motor overload protector has cycled.	Refer to paragraph 47.
Bind in pump.	Disassemble and clean pump or replace pump.
Loading door is open or door switch is inoperative.	Close loading door and test switch and replace if inoperative.

#### 44. CONSTANT AGITATION

POSSIBLE CAUSE	TO CORRECT
Inoperative timer.	Test timer and replace if inoperative.
Inoperative drive motor.	Test motor and replace if inoperative.
Shorted or incorrect wiring.	Refer to appropriate Wiring Diagram.

#### 45. SLOW SPIN OR NO SPIN

POSSIBLE CAUSE	TO CORRECT
Inoperative timer.	Test timer and replace if inoperative.
Inoperative action switch.	Test switch and replace if inoperative.
Loading door is open or door safety switch is inoperative.	Close loading door, or test switch and replace if inoperative.
Bind in water pump.	Disassemble and clean pump or replace pump.
Inoperative drive motor.	Test motor and replace if inoperative.
Loose or broken drive belt.	Adjust or replace belt.
Washer has gone OUT-OF-BALANCE.	Open loading door to reset OUT-OF-BALANCE switch.
No clearance or brake pads sticking.	Free sticky brake pads or replace pads.
Broken, loose, or incorrect wiring.	Refer to appropriate Wiring Diagram.

**46. CONSTANT SPIN**

POSSIBLE CAUSE	TO CORRECT
Inoperative timer.	Test timer and replace if inoperative.
Inoperative drive motor.	Test motor and replace if inoperative.
Excessive wear on brake pads, or missing brake pads.	Replace brake pads.
Shorted or incorrect wiring.	Refer to appropriate Wiring Diagram.

**47. DRIVE MOTOR OVERLOAD PROTECTOR CYCLES REPEATEDLY**

POSSIBLE CAUSE	TO CORRECT
Excessive belt tension.	Adjust belts.
Inoperative motor overload protector.	Replace motor.
Bind in water pump.	Disassemble and clean pump or replace pump.
Bind in transmission.	Replace transmission.
Brake pads binding.	Free binding pads, or replace pads.

**48. OUTER TUB DOES NOT EMPTY**

POSSIBLE CAUSE	TO CORRECT
Kinked drain hose.	Straighten hose.
Inoperative water pump.	Replace pump.
Obstruction in outer tub outlet hose.	Remove obstruction.
Loose pump belt.	Adjust belt.

**49. EXCESSIVE VIBRATION**

POSSIBLE CAUSE	TO CORRECT
Unbalanced load in tub.	Stop washer, redistribute load, then restart washer.
Broken, disconnected or centering spring (s) out of adjustment.	Connect or replace centering spring(s). Spring should be located in center notch, <i>Figure 30</i> .
Washer is not properly leveled.	Adjust leveling legs.
Washer is installed on weak, "spongy", or built-up floor.	Relocate washer, or support floor to eliminate weak or "spongy" condition.
Incorrect or loose cabinet screws.	Replace with correct screws or tighten.

## 50. WATER LEAKING FROM OUTER TUB

POSSIBLE CAUSE	TO CORRECT
Leaking water seal in outer tub.	Replace water seal assembly, paragraph 25.
Hole in outer tub.	Replace outer tub.
Pressure hose or bulb leaking.	Replace pressure hose and/or bulb.
Outer tub cover gasket leaking.	Replace gasket.

# Special Tools

## No. 357P3 Tool Kit

(Includes the five special tools shown below)

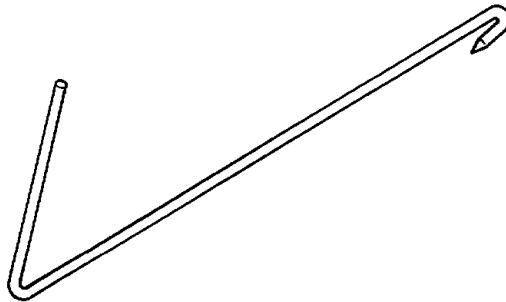

### 229P4 SPRING HOOK

Use for the removal of the five centering springs from the outer tub.

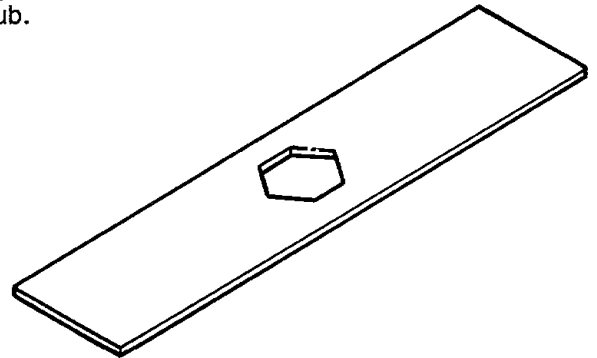

### 237P4 HEX WRENCH

Used to remove hex locknut from washtub hub.

### 242P4 BRAKE SPRING INSTALLER

Used to install brake spring.

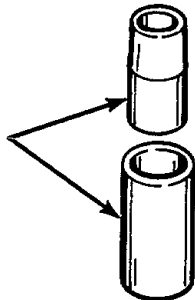

### 241P4 SEAL INSTALLER

Used to install No. 356P3 Washer Seal Kit.

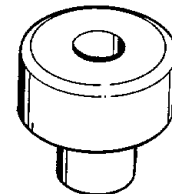
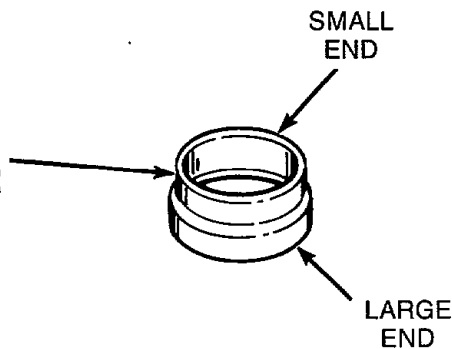

### 230P4 GUIDE SPINDLE

Used for the removal of the hub from the transmission.

# SECTION V

## Test Procedures

### G.E. MOTOR CHECK (Start Windings)

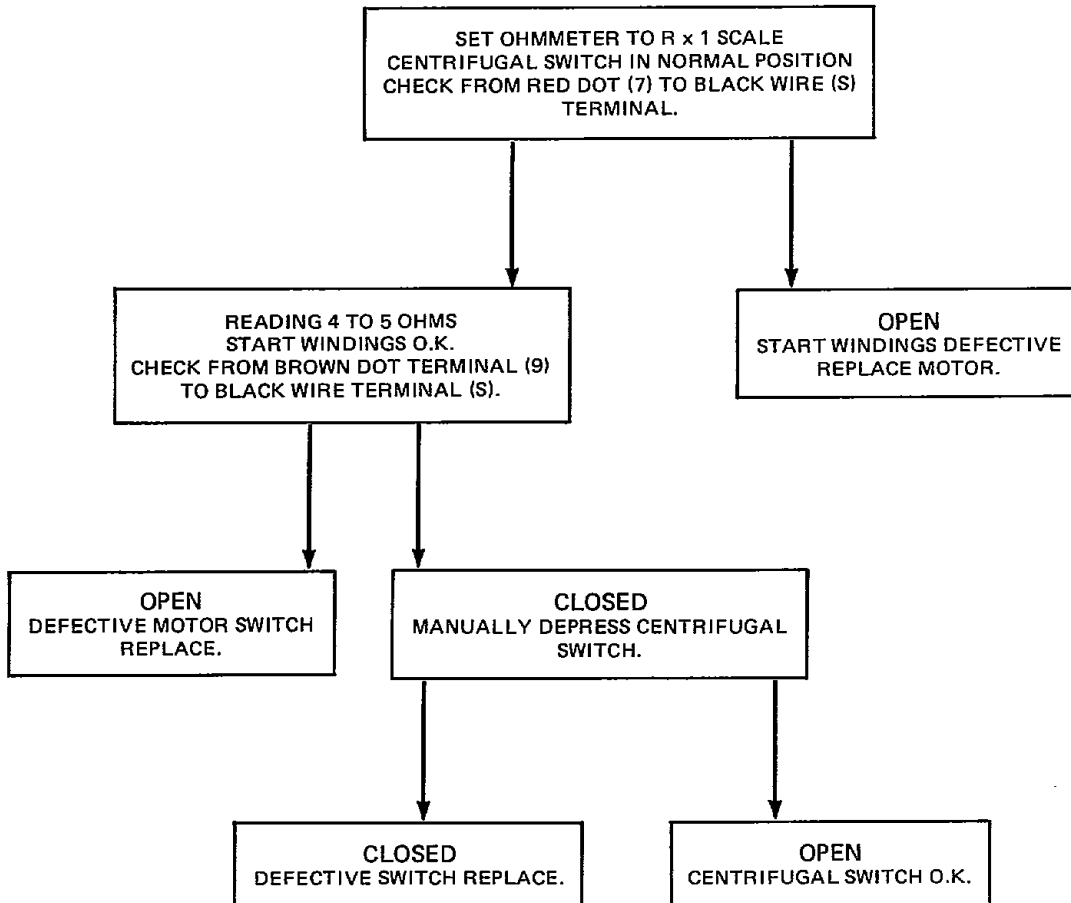

# G.E. MOTOR CHECK (High and Low Windings)

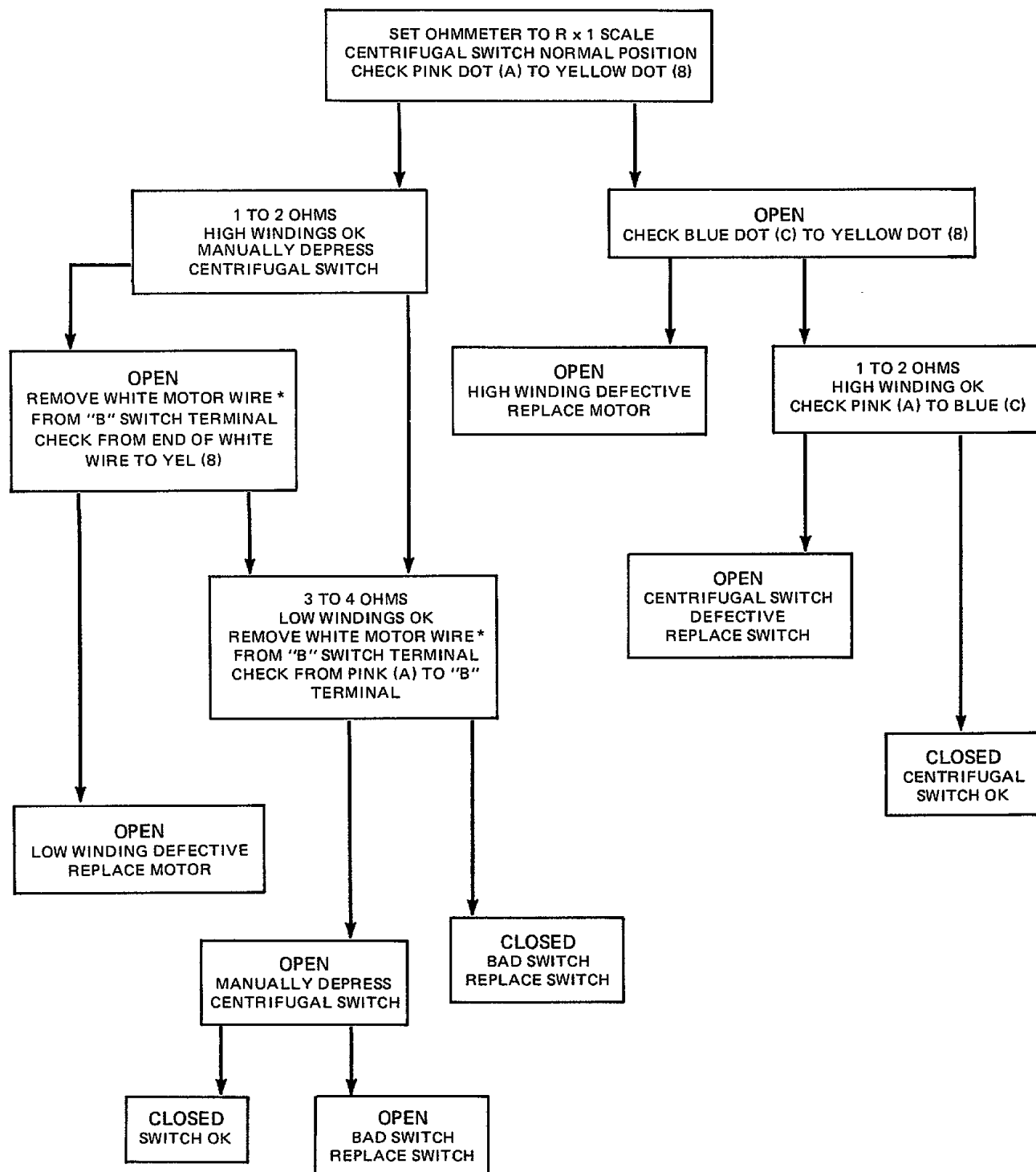

\* Do not confuse white wire coming from wire harness to white dot on motor switch with the white wire coming from the motor to the "B" terminal.

# SECTION VI

## Cycle Sequence Charts

CYCLE	FUNCTION	WATER TEMP.	MOTOR SPEED	TIME FUNCTION	DEGREES FUNCTION
	WASH, FILL or AGITATE	H, W, C	F or S	7:20	150°
	PAUSE			:10	
	SPIN		F or S	1:30	30°
	SPIN & SPRAY	COLD	F or S	:23	20°
	SPIN		F or S	:30	
	SPIN & SPRAY	COLD	F or S	:07	
	SPIN		F or S	:27	10°
	PAUSE			:03	20°
	PAUSE or RINSE FILL (Timer Motor Runs)	COLD		:55	
	PAUSE & FILL	COLD		:05	
	RINSE, AGITATE & FILL	COLD	F or S	:50	20°
	PAUSE			:10	100°
	SPIN		F or S	5:00	
	OFF (Timer Motor Run - Out)			:30	
	<b>TOTAL</b>			<b>18:00</b>	<b>360°</b>

KEY: H = HOT W = WARM C = COLD F = FAST S = SLOW

### Timer No. 27755 Cycle Sequence (Short Cycle - Mallory)

CYCLE	FUNCTION	WATER TEMP.	MOTOR SPEED	TIME FUNCTION	DEGREES FUNCTION
	WASH, FILL or AGITATE	H, W, C	F or S	11:43	152°
	PAUSE			:10	
	SPIN		F or S	1:53	24°
	SPIN & SPRAY	COLD	F or S	:26	16°
	SPIN		F or S	:37½	
	SPIN & SPRAY	COLD	F or S	:07	
	SPIN		F or S	1:12	16°
	PAUSE			:03	
	RINSE FILL (Timer Motor Runs)	COLD		:32½	8°
	PAUSE or FILL	COLD		:05	
	RINSE, AGITATE & FILL	COLD	F or S	2:58	40°
	PAUSE			:10	
	SPIN		F or S	7:30	96°
	OFF (Timer Motor Run-Out)			:37½	8°
	<b>TOTAL</b>			<b>28:07½</b>	<b>360°</b>

KEY: H = HOT C = COLD F = FAST W = WARM S = SLOW

## Timer No's. 27756 & 27757 Cycle Sequence (Long Cycle - Mallory)



CYCLE	FUNCTION	WATER TEMP.	CYCLE AND MOTOR SPEED	TIME FUNCTION	DEGREE FUNCTION
	WASH FILL or AGITATE	H, W, C	N=FAST PP=FAST D=SLOW	7:23	150°
	PAUSE			:07	
	SPIN		N=FAST PP=SLOW D=SLOW	1:30	30°
	SPIN & SPRAY	COLD	N=FAST PP=SLOW D=SLOW	:23	20°
	SPIN		N=FAST PP=SLOW D=SLOW	:30	
	SPIN & SPRAY	COLD	N=FAST PP=SLOW D=SLOW	:05	
	SPIN		N=FAST PP=SLOW D=SLOW	:27	10°
	PAUSE			:03	20°
	RINSE FILL	COLD		:55	
	PAUSE or FILL	COLD		:05	
	RINSE FILL or AGITATE	COLD	N=FAST PP=FAST D = SLOW	:53	20°
	PAUSE			:07	
	SPIN		N=FAST PP=FAST D=FAST	5:00	100°
	TIMER MOTOR RUN OUT			:30	10°

KEY: F = FAST S = SLOW H = HOT W = WARM C = COLD

## Timer No. 27755 Cycle Sequence (Short Cycle - Kingston)

CYCLE	FUNCTION	WATER TEMP.	CYCLE AND MOTOR SPEED	TIME FUNCTION	DEGREE FUNCTION
	WASH FILL & AGITATE	H, W, C	N=FAST PP=FAST D=SLOW	11:42	152°
	PAUSE			:11	
	SPIN		N=FAST PP=SLOW D=SLOW	1:53	24°
	SPIN & SPRAY	COLD	N=FAST PP=SLOW D=SLOW	:23	16°
	SPIN		N=FAST PP=SLOW D=SLOW	:37½	
	SPIN & SPRAY	COLD	N=FAST PP=SLOW D=SLOW	:05	
	SPIN		N=FAST PP=SLOW D=SLOW	1:12	16°
	PAUSE			:03	
	RINSE FILL	COLD		:32½	8°
	PAUSE & FILL	COLD		:05	
	RINSE, AGITATE & FILL	COLD	N=FAST PP=FAST D=SLOW	2:57	40°
	PAUSE			:11	
	SPIN		N=FAST PP=FAST D=FAST	7:30	96°
	TIMER MOTOR RUN OUT			37½	8°

KEY: F = FAST S = SLOW H = HOT W = WARM C = COLD

## Timer No's. 27756 & 27757 Cycle Sequence (Long Cycle - Kingston)

# SECTION VII

## Circuitry Schematics

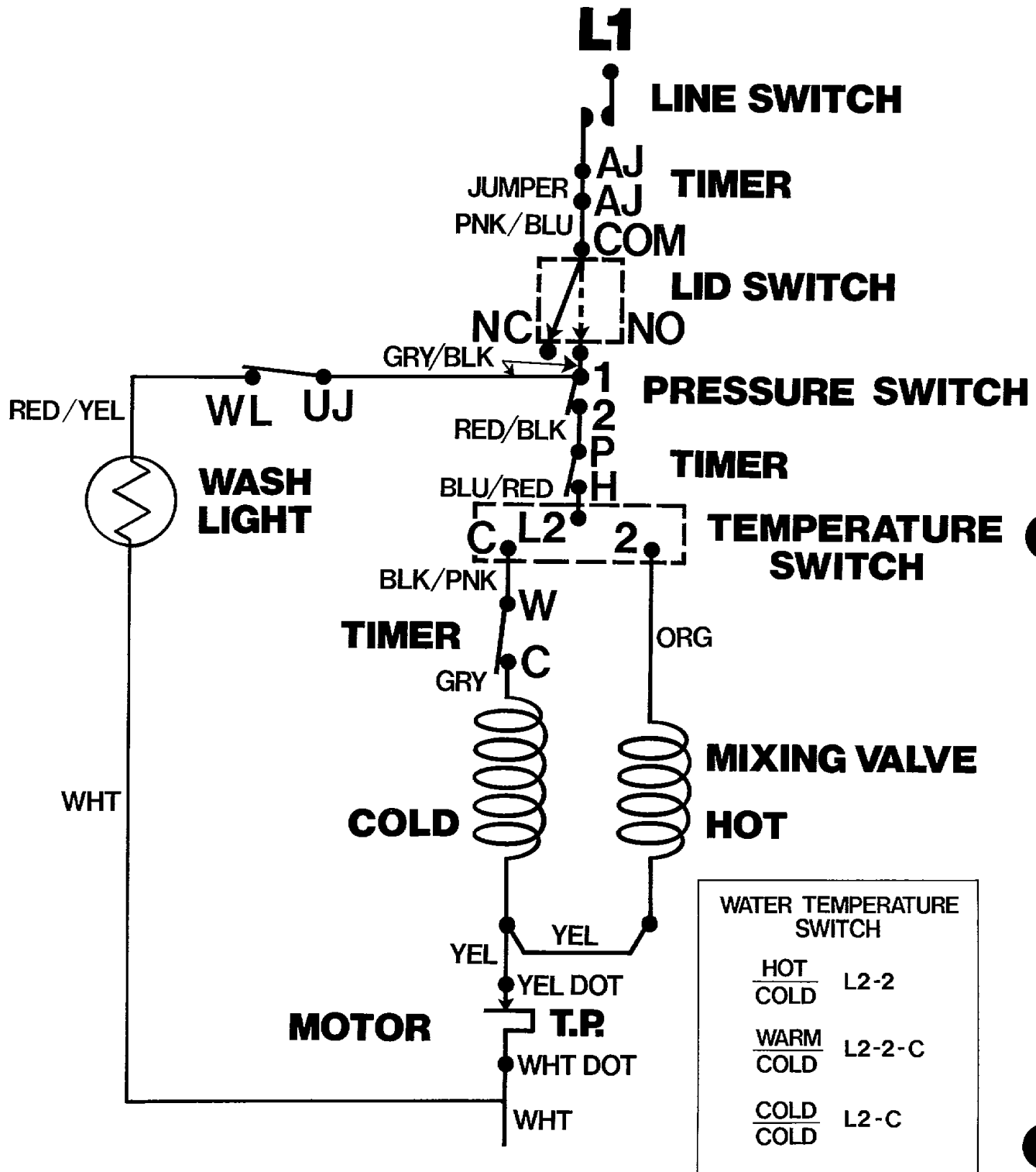

WATER TEMPERATURE SWITCH	
<u>HOT</u>	L2-2
<u>COLD</u>	L2-2
<u>WARM</u>	L2-2-C
<u>COLD</u>	L2-2-C
<u>COLD</u>	L2-C
<u>COLD</u>	L2-C

**WASH FILL**

**N**

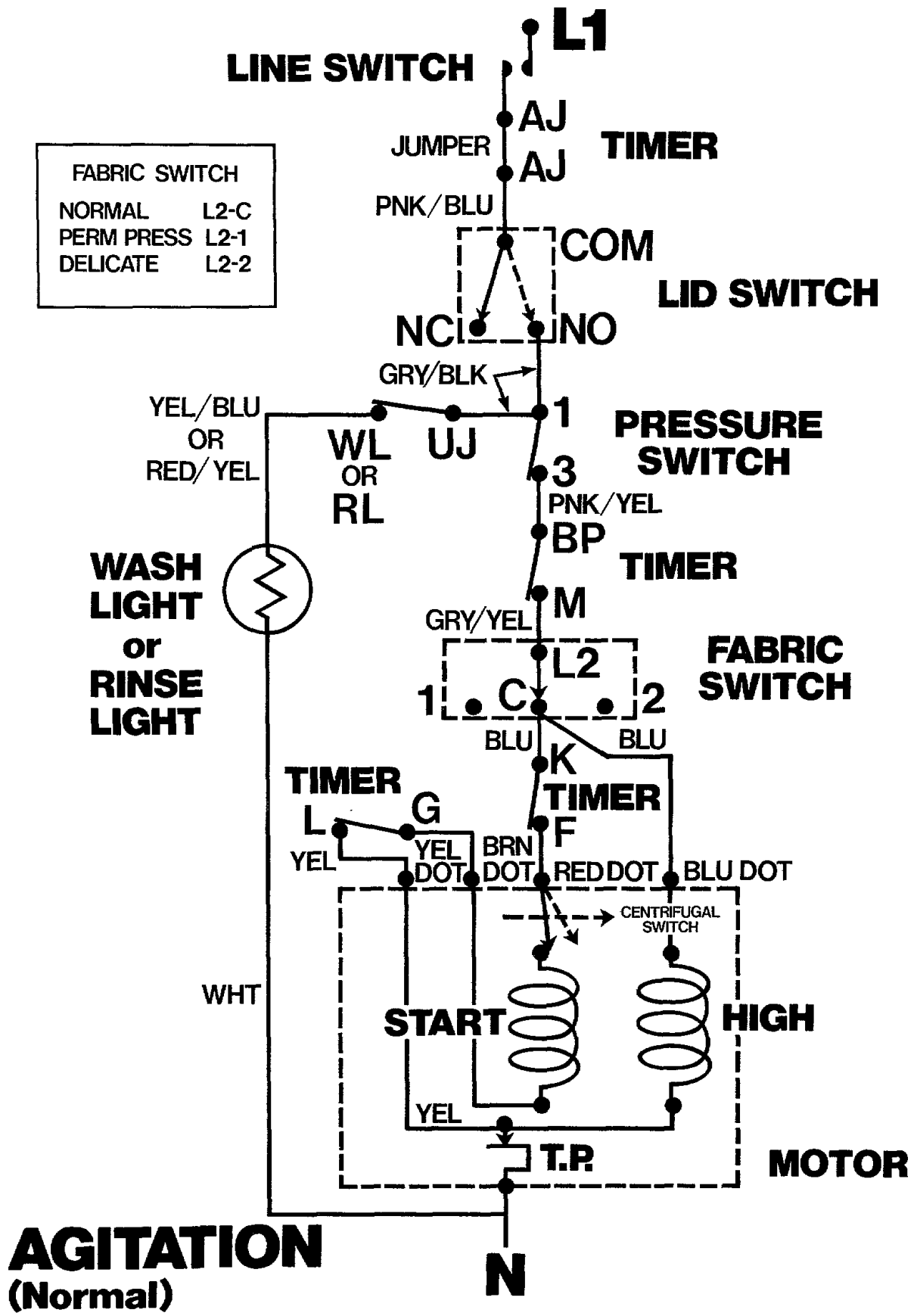

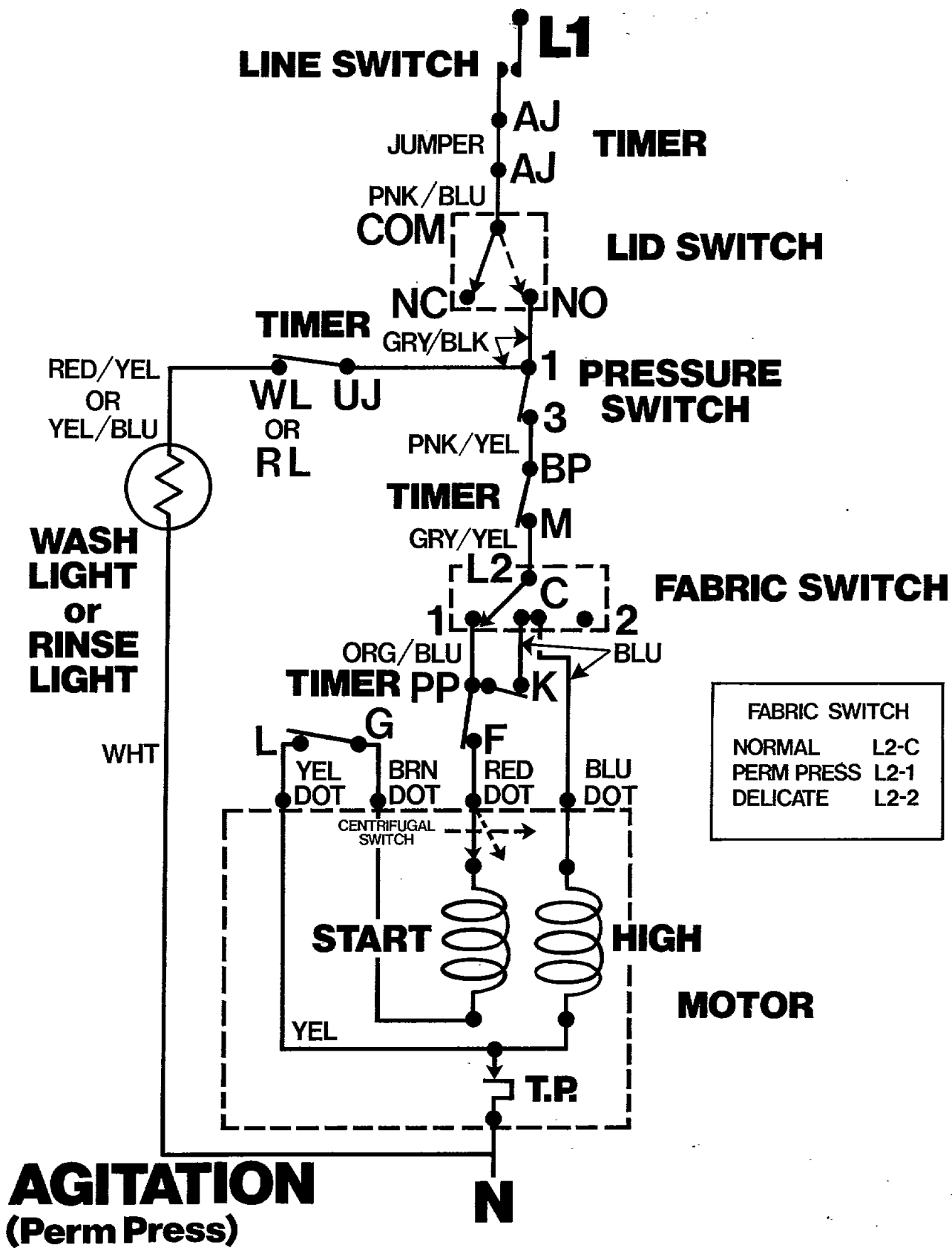

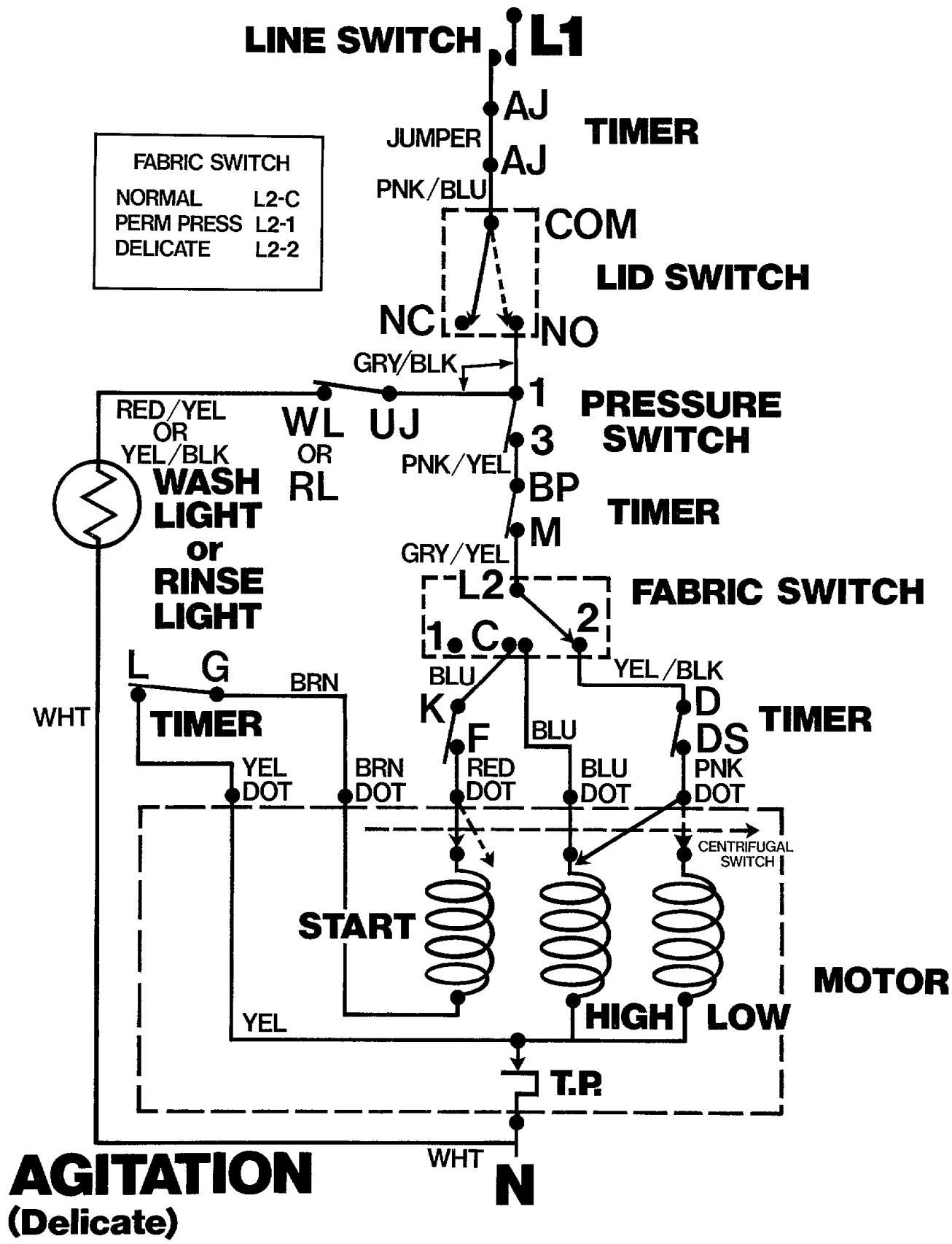

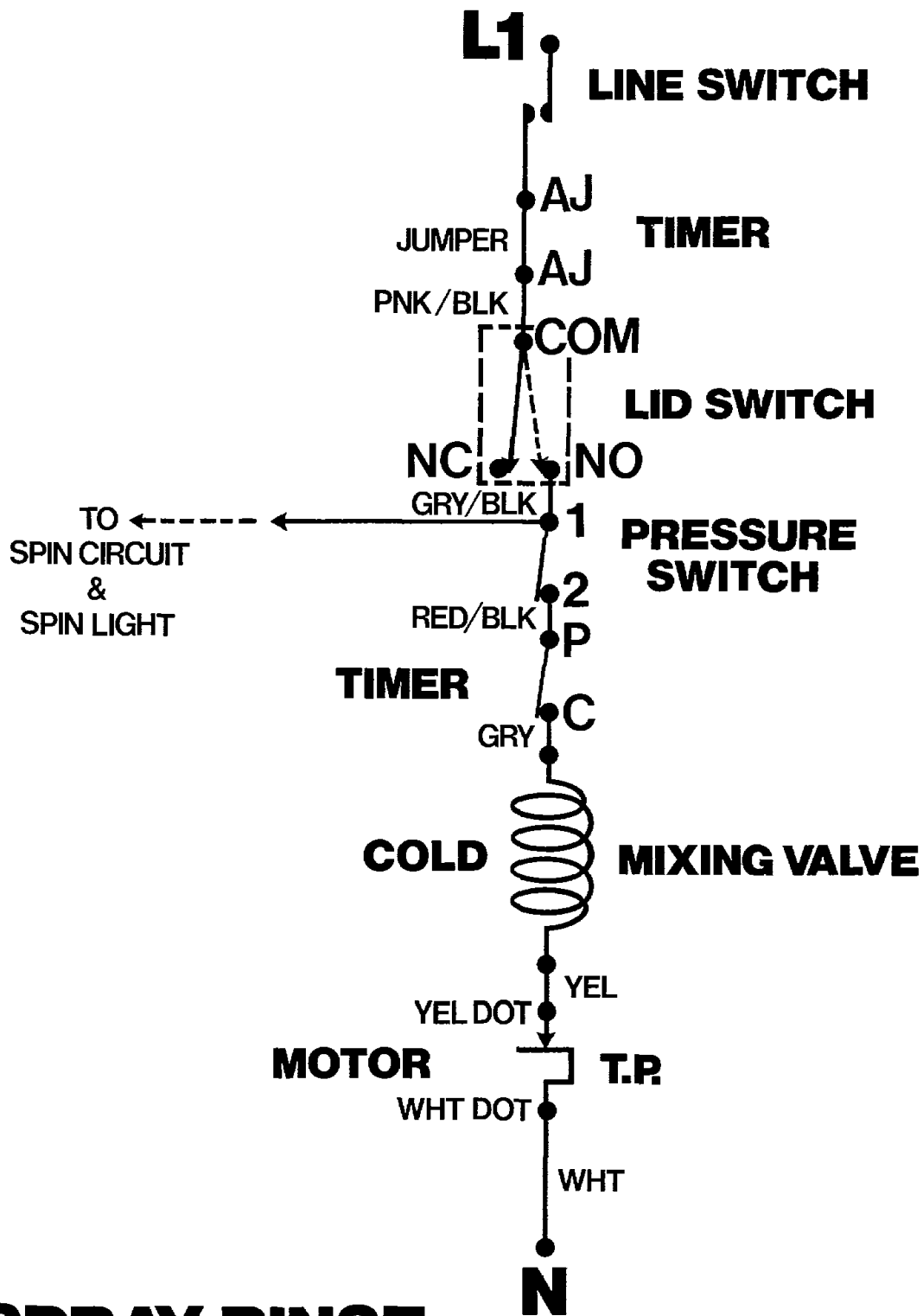

# SPRAY RINSE

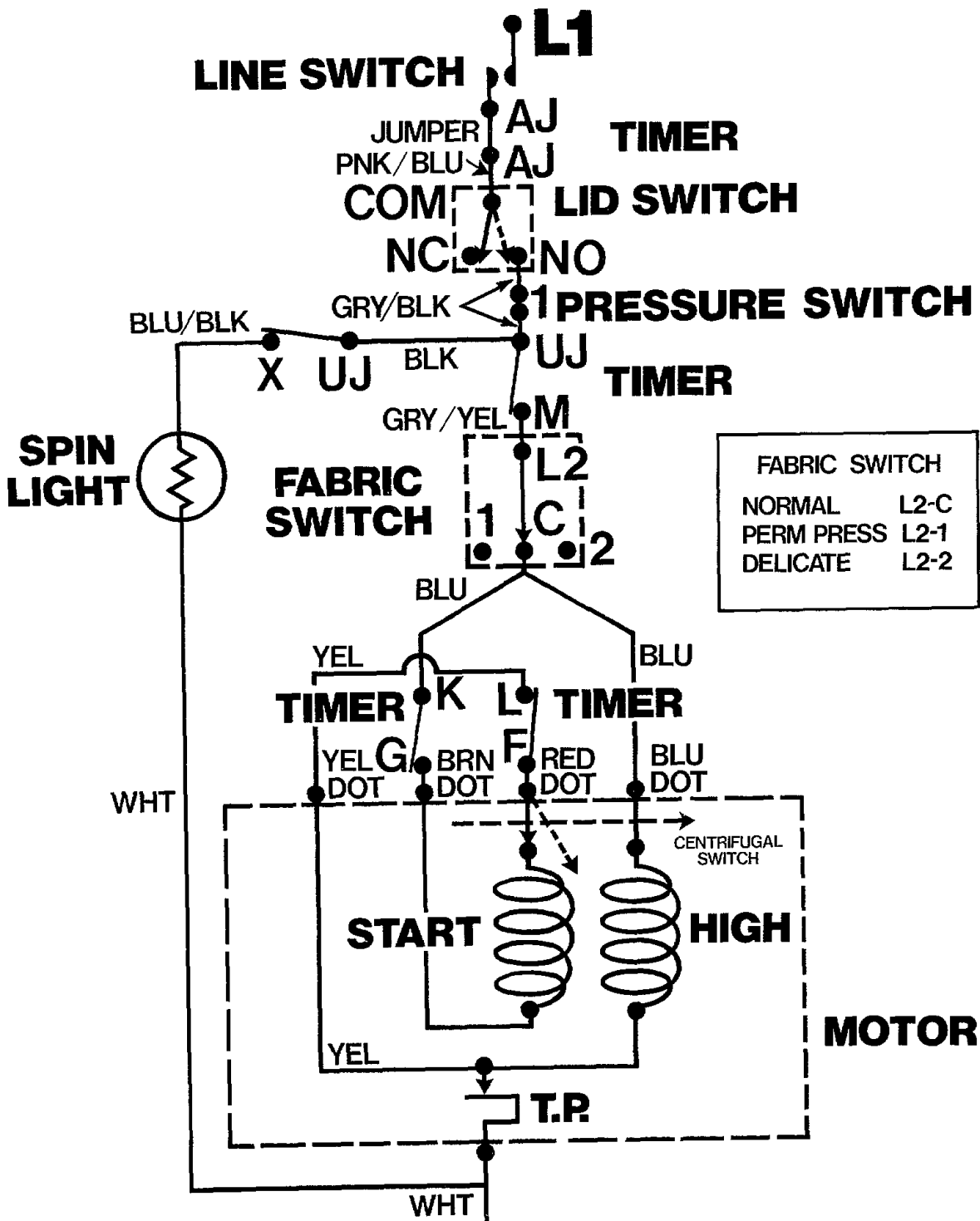

● **FIRST & SECOND SPIN (Fast) Normal Setting**



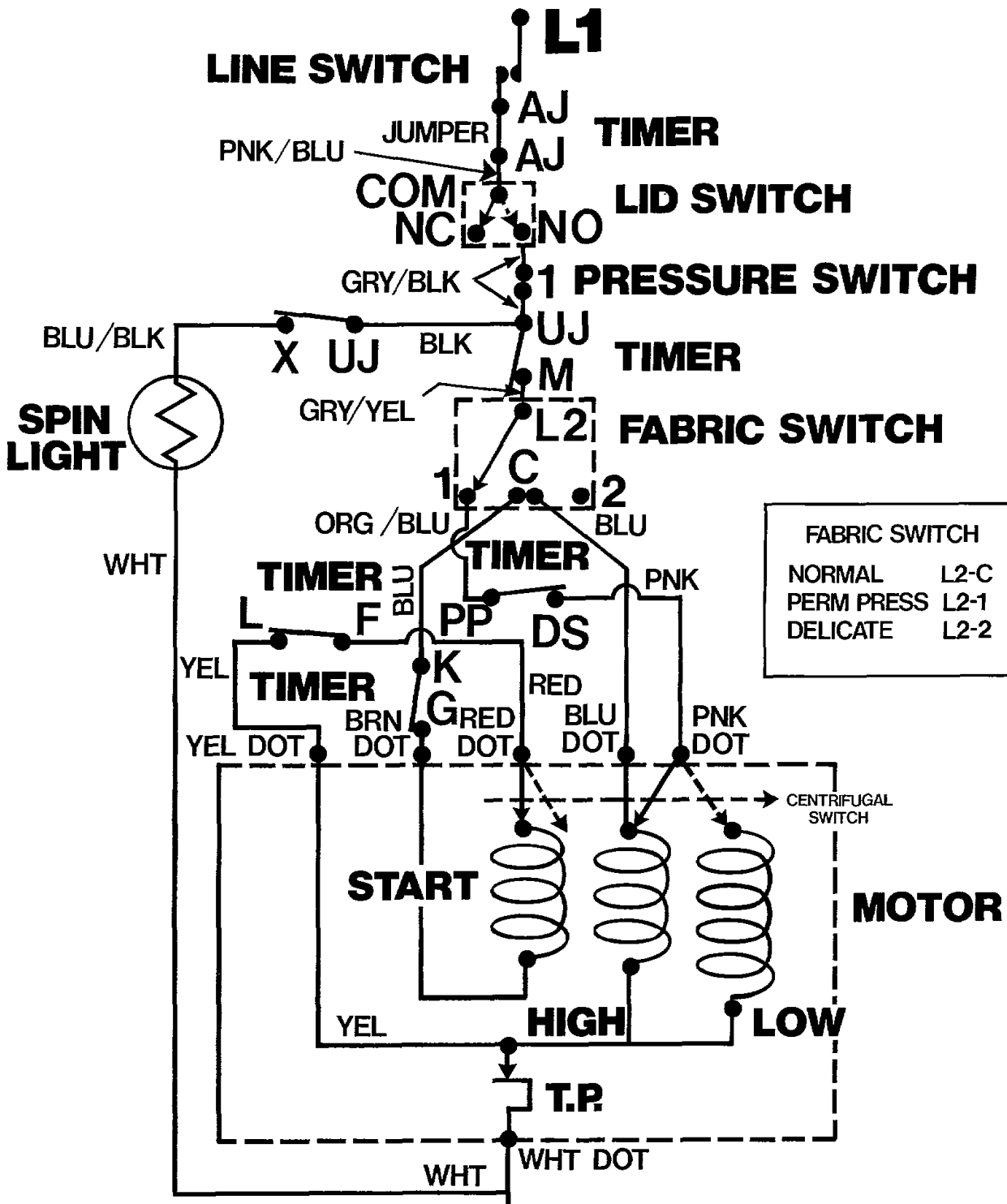

# FIRST SPIN

## (Slow) Perm Press Setting

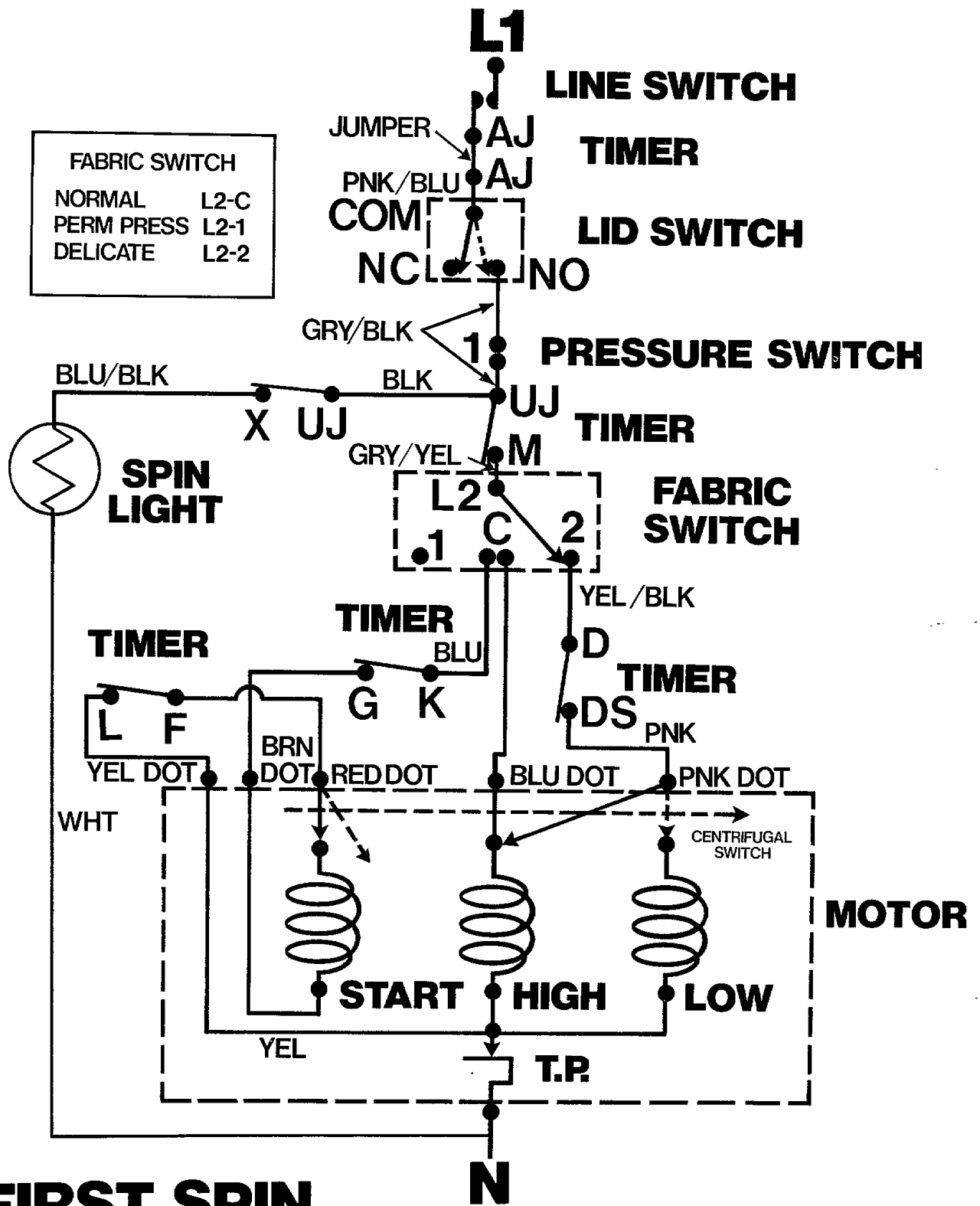

# FIRST SPIN

(Slow) Delicate Setting

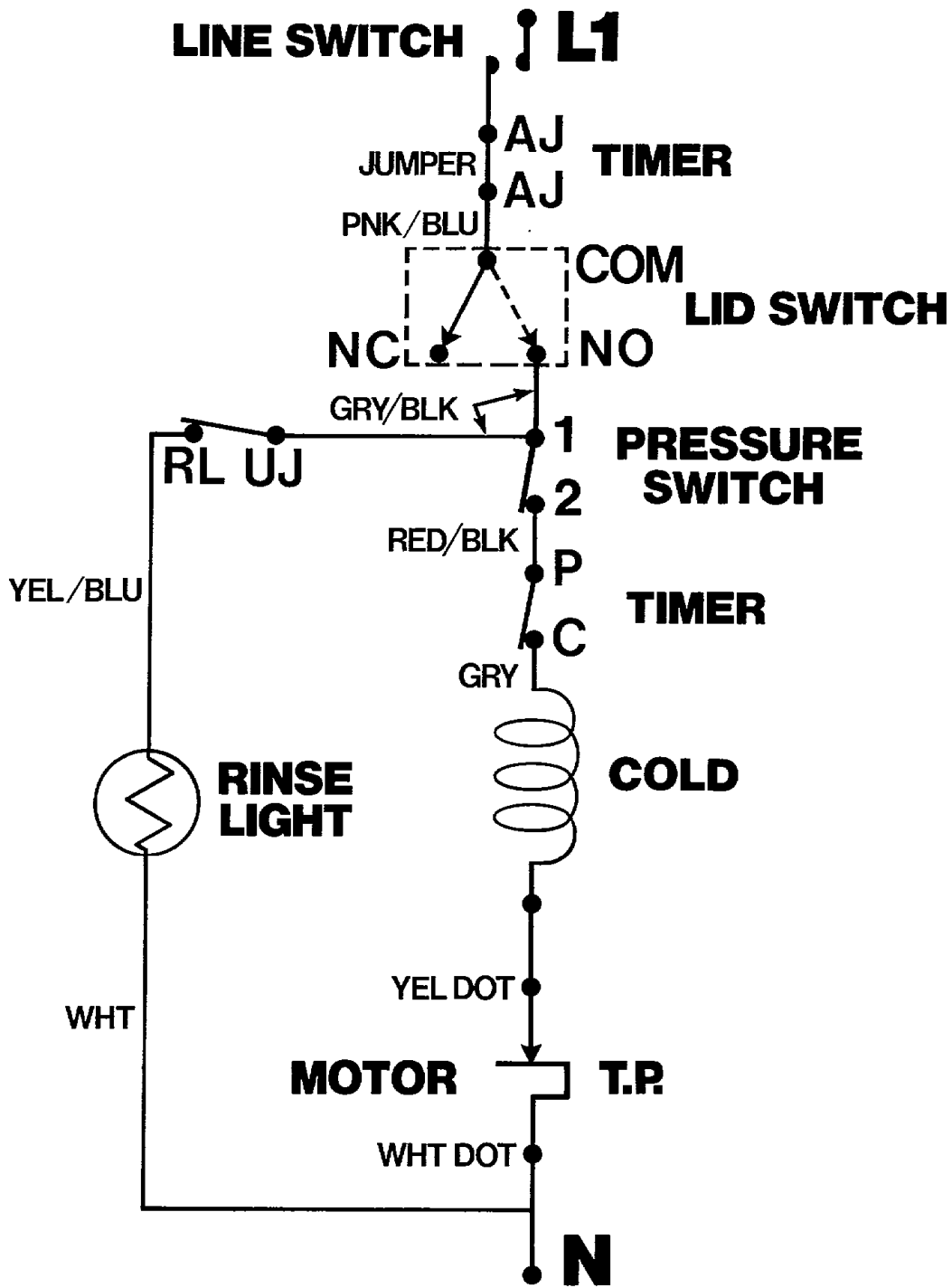

# RINSE FILL

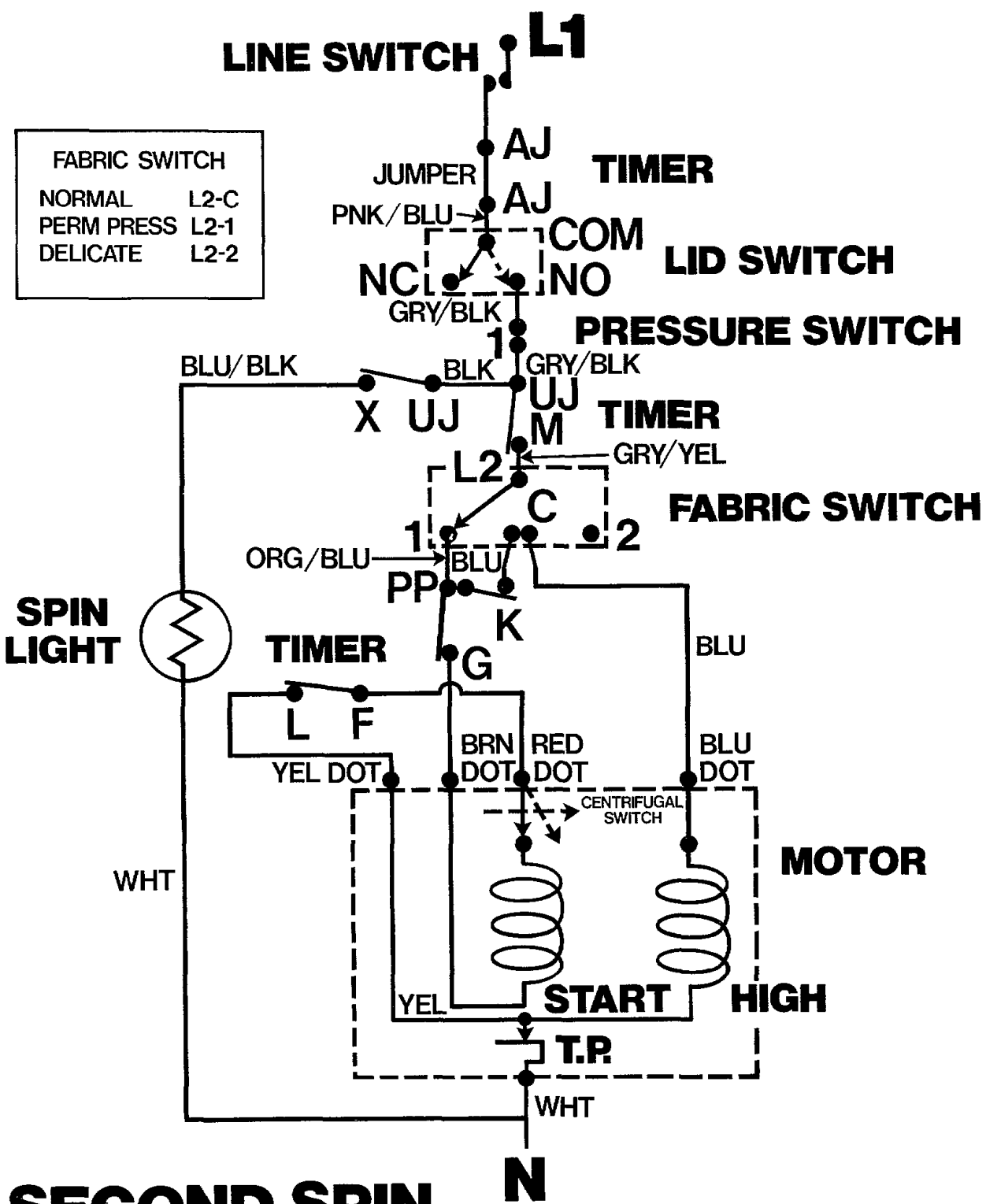

**SECOND SPIN**  
**(Fast) Perm Press Setting**

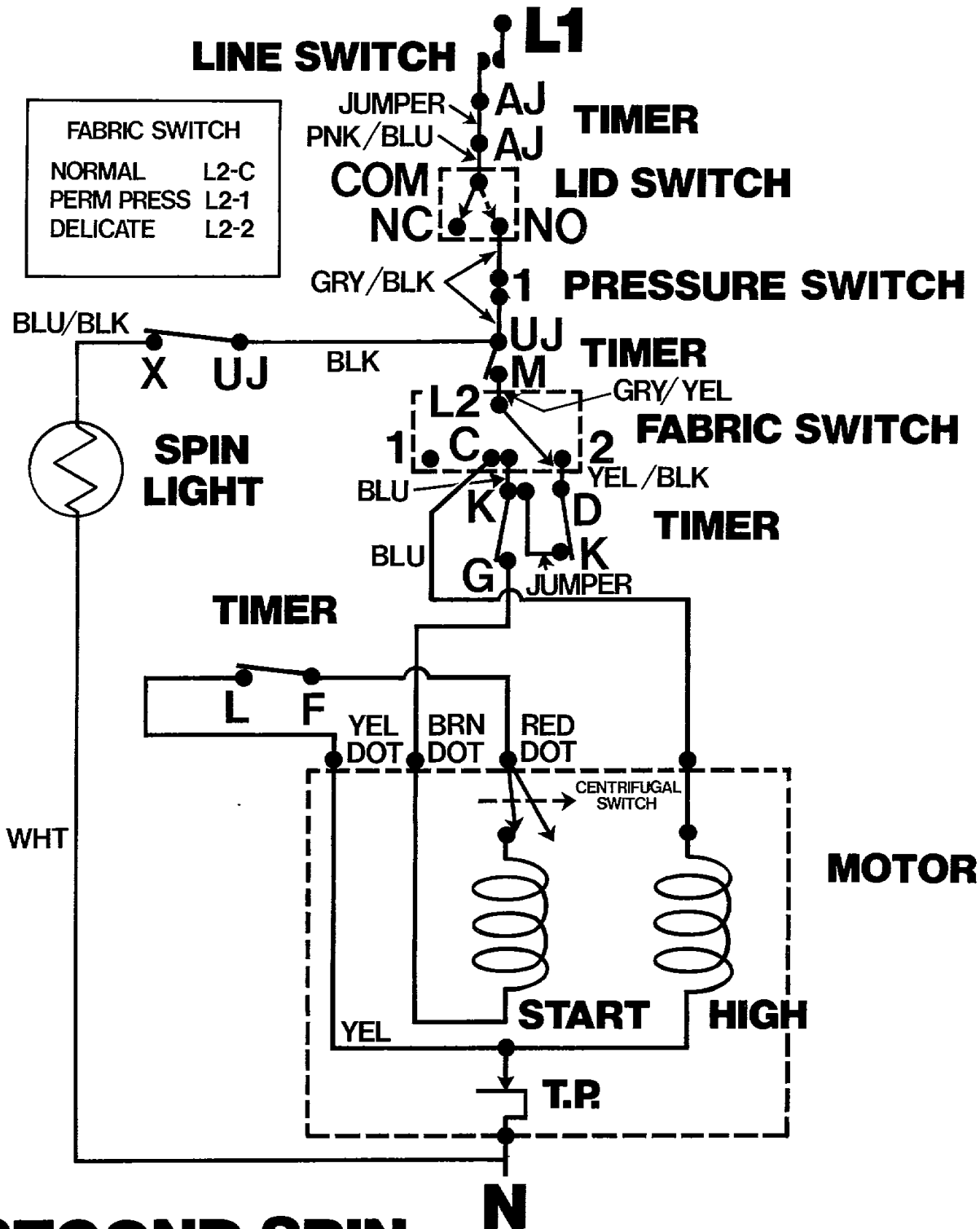

# SECOND SPIN

(Fast) Delicate Setting



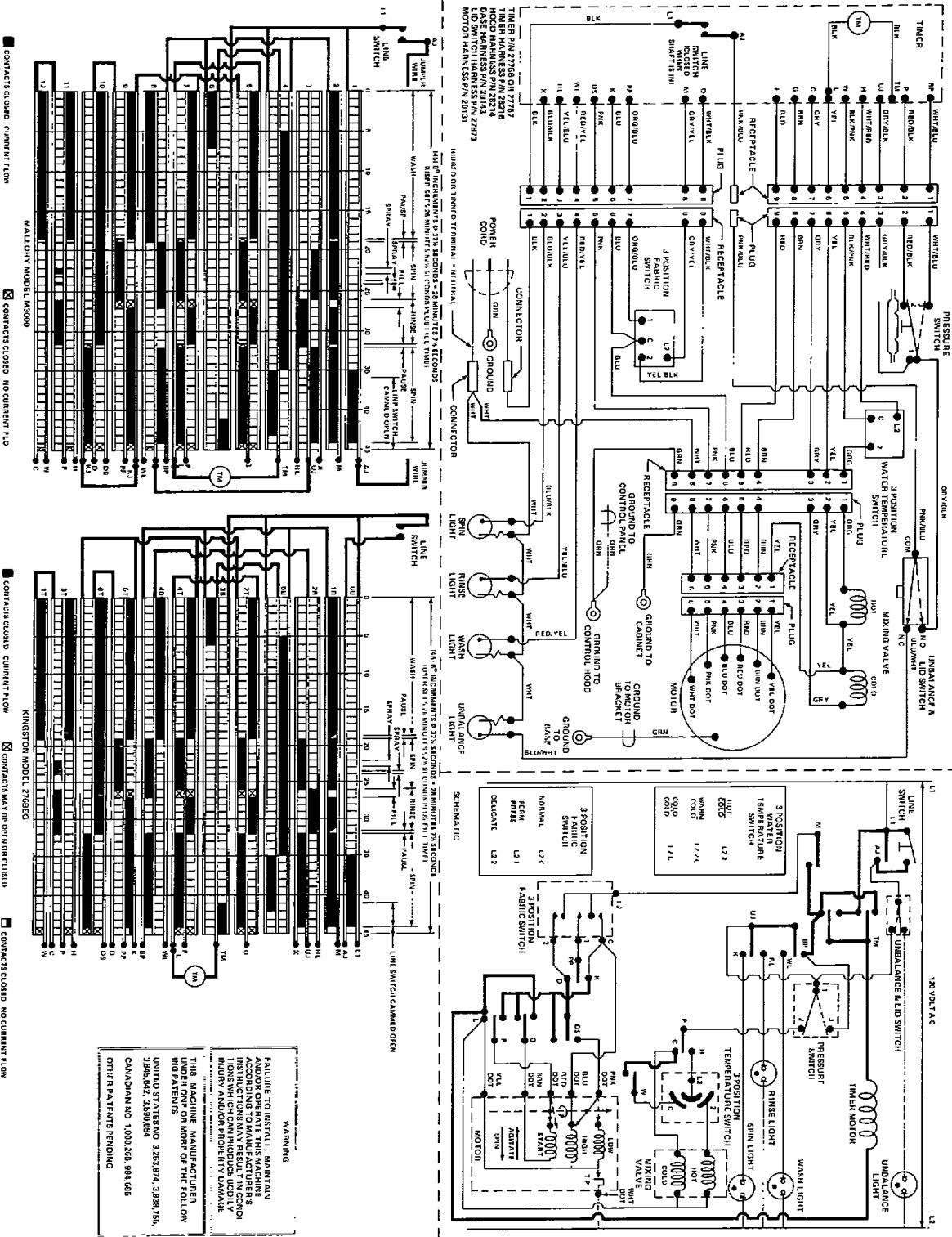

# Models SA4720, SA4721, SA4724, SA4725, SA4980, SA4981, SA4982, SA4983, SA4984 & SA4985

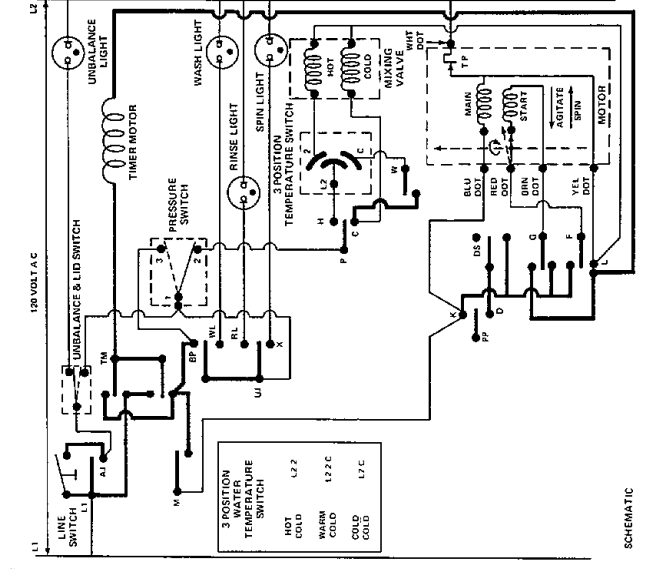

**WARNING**  
 FAILURE TO INSTALL, MAINTAIN AND/OR OPERATE THIS MACHINE ACCORDING TO MANUFACTURER'S INSTRUCTIONS MAY CAUSE PERSONAL INJURY AND/OR PROPERTY DAMAGE.  
 THIS MACHINE MANUFACTURED UNDER ONE OR MORE OF THE FOLLOWING PATENTS  
 UNITED STATES NO. 3,253,874; 3,838,751; 3,845,842; 3,890,654  
 CANADIAN NO. 1,008,265; 994,885  
 OTHER PATENTS PENDING

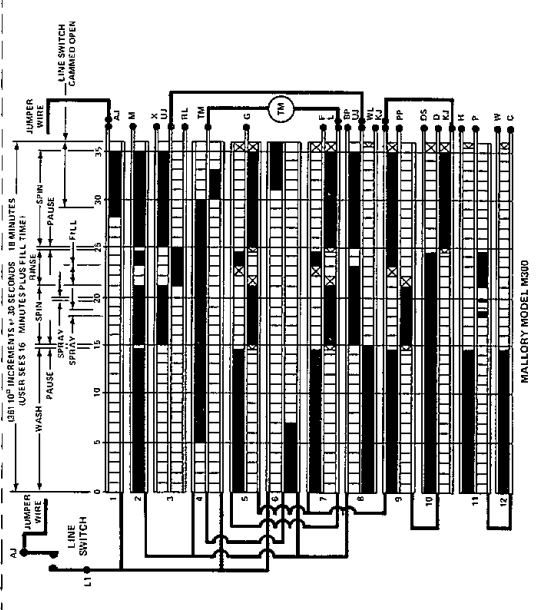
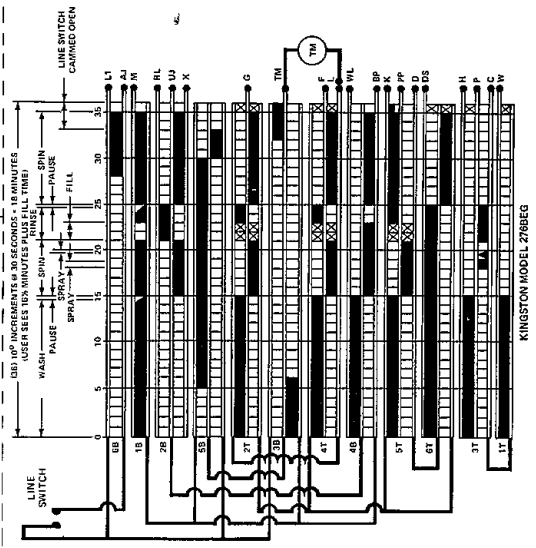
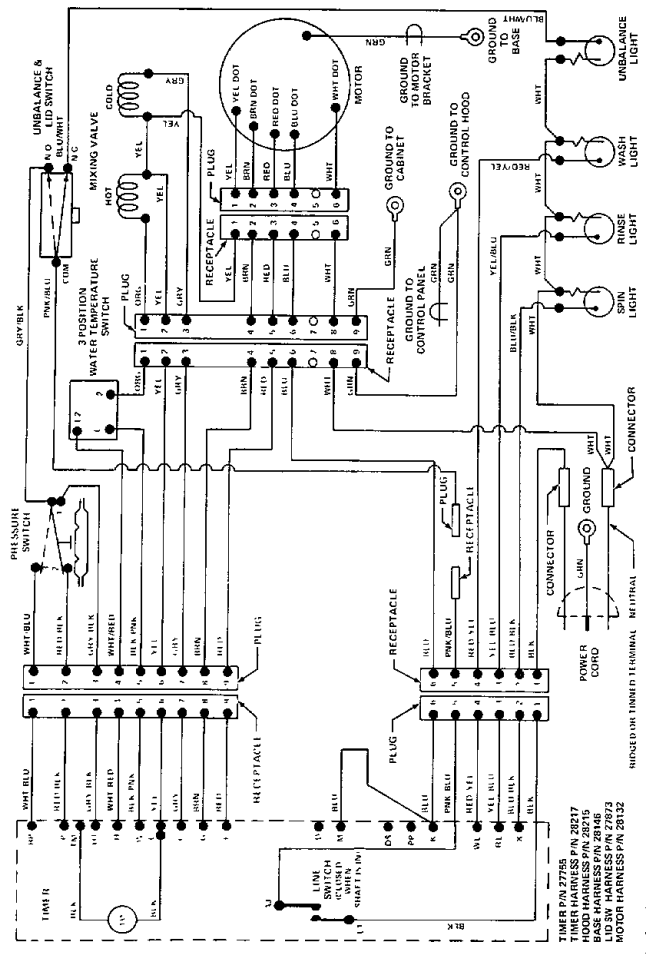

■ CONTACTS CLOSED CURRENT FLOW    □ CONTACTS CLOSED NO CURRENT FLOW    □ CONTACTS OPEN

# Models SA4950, SA4951, SA4954 & SA4955



CONTACTS CLOSED, CURRENT FLOW

CONTACTS CLOSED, NO CURRENT FLOW

CONTACTS CLOSED, CURRENT FLOW

CONTACTS OPEN, NO CURRENT FLOW

CONTACTS MAY BE OPEN OR CLOSED

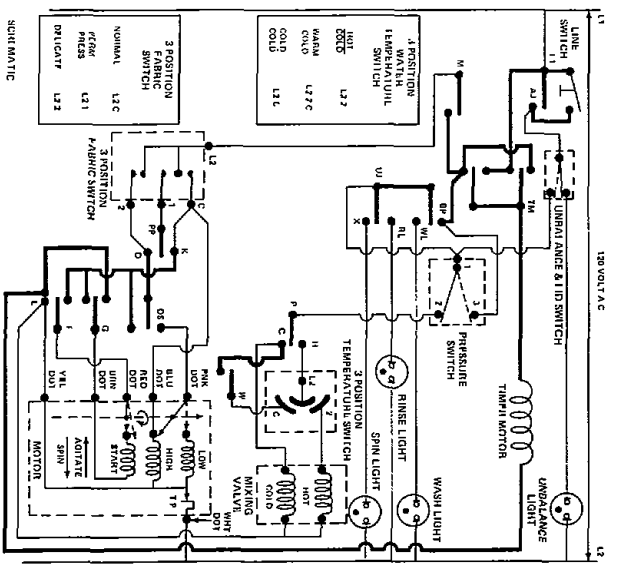
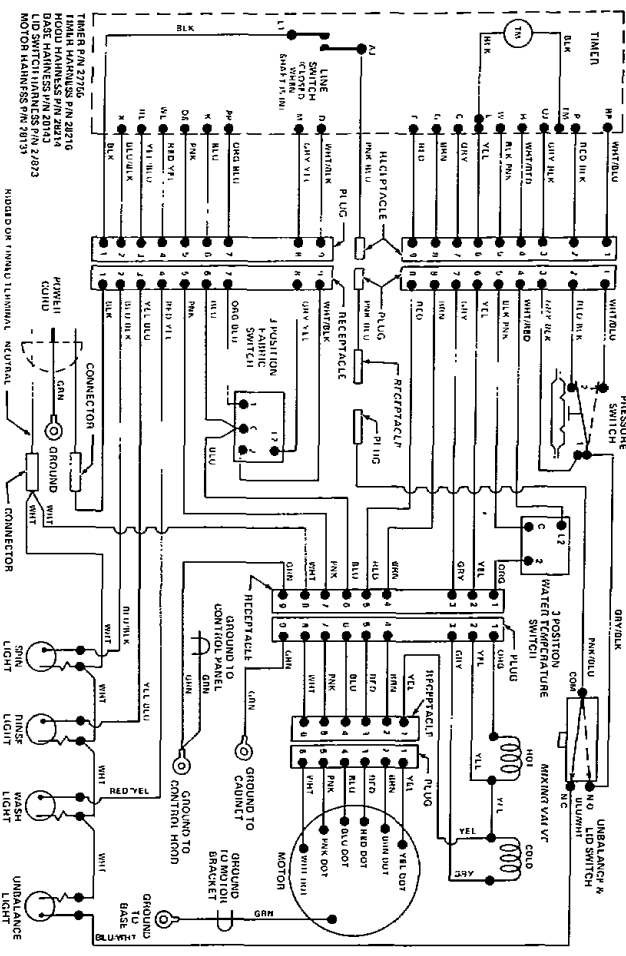
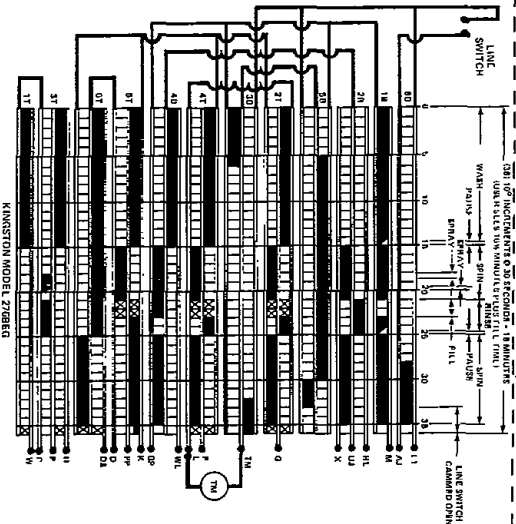
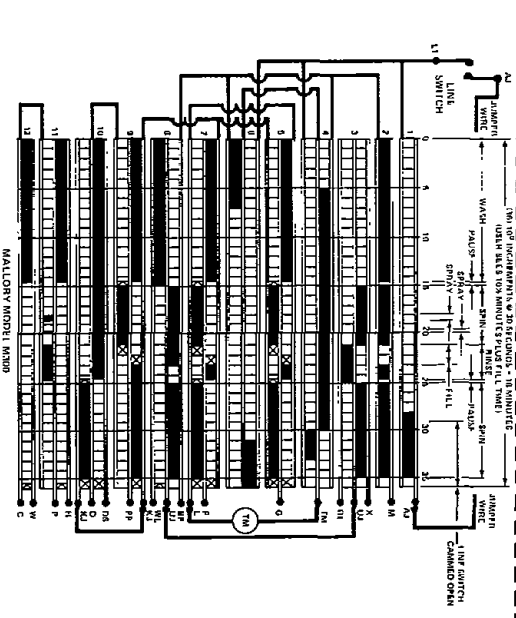

**WARNING**

FAILURE TO INSTALL, MAINTAIN AND/OR OPERATE THIS MACHINE AS INSTRUCTIONS MAY RESULT IN CON-DITIONS WHICH CAN PRODUCE FATAL INJURY AND/OR PROPERTY DAMAGE.

THIS MACHINE MANUFACTURED UNDER PATENTS

UNITED STATES NO. 3,263,874, 3,288,866, 3,291,941, 3,299,929

CANADIAN NO. 1,080,250, 994,197

OTHER PATENTS PENDING

# Models SA4970, SA4971, SA4974 & SA4975