



# AD-50V

## Parts Manual

### 24 VAC Phase 5

---

**American Dryer Corporation**  
88 Currant Road  
Fall River, MA 02720-4781  
Telephone: (508) 678-9000 / Fax: (508) 678-9447  
E-mail: [techsupport@amdry.com](mailto:techsupport@amdry.com)

[www.amdry.com](http://www.amdry.com)

# Retain This Manual In A Safe Place For Future Reference

American Dryer Corporation products embody advanced concepts in engineering, design, and safety. If this product is properly maintained, it will provide many years of safe, efficient, and trouble free operation.

**ONLY qualified technicians should service this equipment.**

**OBSERVE ALL SAFETY PRECAUTIONS** displayed on the equipment or specified in the installation manual included with the dryer.

The following “**FOR YOUR SAFETY**” caution must be posted near the dryer in a prominent location.

## FOR YOUR SAFETY

Do not store or use gasoline or other flammable vapors and liquids in the vicinity of this or any other appliance.

## POUR VOTRE SÉCURITÉ

Ne pas entreposer ni utiliser d'essence ni d'autres vapeurs ou liquides inflammables à proximité de cet appareil ou de tout autre appareil.

We have tried to make this manual as complete as possible and hope you will find it useful. ADC reserves the right to make changes from time to time, without notice or obligation, in prices, specifications, colors, and material, and to change or discontinue models.

## Important

For your convenience, log the following information:

DATE OF PURCHASE \_\_\_\_\_ MODEL NO. **AD-50V**  
RESELLER'S NAME \_\_\_\_\_  
Serial Number(s) \_\_\_\_\_  
\_\_\_\_\_  
\_\_\_\_\_

Replacement parts can be obtained from your reseller or the ADC factory. When ordering replacement parts from the factory, you can FAX your order to ADC at (508) 678-9447 or telephone your order directly to the ADC Parts Department at (508) 678-9000. Please specify the dryer model number and serial number in addition to the description and part number, so that your order is processed accurately and promptly.

The illustrations on the following pages may not depict your particular dryer exactly. The illustrations are a composite of the various dryer models. Be sure to check the descriptions of the parts thoroughly before ordering.

### **“IMPORTANT NOTE TO PURCHASER”**

Information must be obtained from your local gas supplier on the instructions to be followed if the user smells gas. These instructions must be posted in a prominent location near the dryer.

# Table of Contents

Non-Coin Control Door Assembly for Models Mfd. as of July 1, 2002 .....	4
Coin Control Door Assembly for Models Mfd. as of July 1, 2002 .....	5
Control Door Assembly for Models Mfd. prior to July 1, 2002 .....	6
Phase 5 Coin Microprocessor Control Panel Assembly .....	7
Phase 5 Non-Coin Microprocessor Control Panel Assembly .....	8
Coin and Non-Coin Control Box Assembly .....	9
Coin Vault Assembly .....	10
Dual Timer "Tap Touch" Controls for Models Mfd. as of November 1, 2000 .....	11
Dual Timer Control Panel Assembly for Models Mfd. prior to November 1, 2000 .....	12
Non-Microprocessor Coin Meter Control Panel Assembly for Models Mfd. as of January 25, 2002 .....	13
Non-Microprocessor Coin Meter Control Panel Assembly for Models Mfd. prior to January 25, 2002 .....	14
Front Panel Assembly for Models Mfd. with Steel Main Door .....	15
Front Panel Assembly for Models Mfd. with Plastic Main Door .....	16
Main Door "Steel" Assembly .....	17
Plastic Main Door Assembly .....	18
Main Door Switch Assembly for Models Mfd. with Steel Main Door .....	19
Main Door Switch for Models Mfd. with Plastic Main Door .....	20
Lint Drawer / Lint Drawer Switch Assemblies for Models Mfd. prior to August 10, 2000 and as of April 19, 2003 .....	21
Lint Drawer / Lint Drawer Switch Assemblies for Models Mfd. between August 10, 2000 and April 18, 2003 .....	22
Idler Bearing Assembly .....	23
Tumbler Bearing Assembly for Models Mfd. as of July 17, 2000 .....	24
Tumbler Bearing Assembly for Models Mfd. prior to July 17, 2000 .....	26
Tumbler / Support Assemblies .....	28
Non-Reversing T.E.F.C. Motor Mount Assembly .....	30
Reversing T.E.F.C. Motor Mount Assembly .....	32
Sensor Bracket Assemblies .....	34
Direct Spark Ignition Burner Assembly for Models Mfd. as of April 7, 2000 .....	36
Direct Spark Ignition Burner Assembly for Models Mfd. prior to April 7, 2000 .....	37
Electric Oven Assembly .....	38
Gas Burner Sail Switch / Hi-Limit Assemblies .....	40
Single-Phase (1 $\phi$ ) Motor, Electric Relay Panel Assembly .....	41
3-Phase (3 $\phi$ ) Motor, Electric Relay Panel Assembly .....	42
460-480 VAC 3-Phase (3 $\phi$ ) Motor, Electric Relay Panel Assembly .....	44
Reversing Electric Relay Panel Assembly .....	45
460-480 VAC Reversing Electric Relay Panel Assembly .....	46
Steam Coil / Air-Operated Steam Damper Assembly .....	47
Steam Coil / Mechanical Steam Damper Assembly Option .....	48
Outer Top / Back Guard Assemblies .....	49
Microprocessor Coin Acceptors Listing .....	50
Coin Meter Replacement Parts .....	51
Electric Oven Component Application Chart .....	52
Additional Parts Available .....	53

# Non-Coin Control Door Assembly

For Models Mfd. as of July 1, 2002

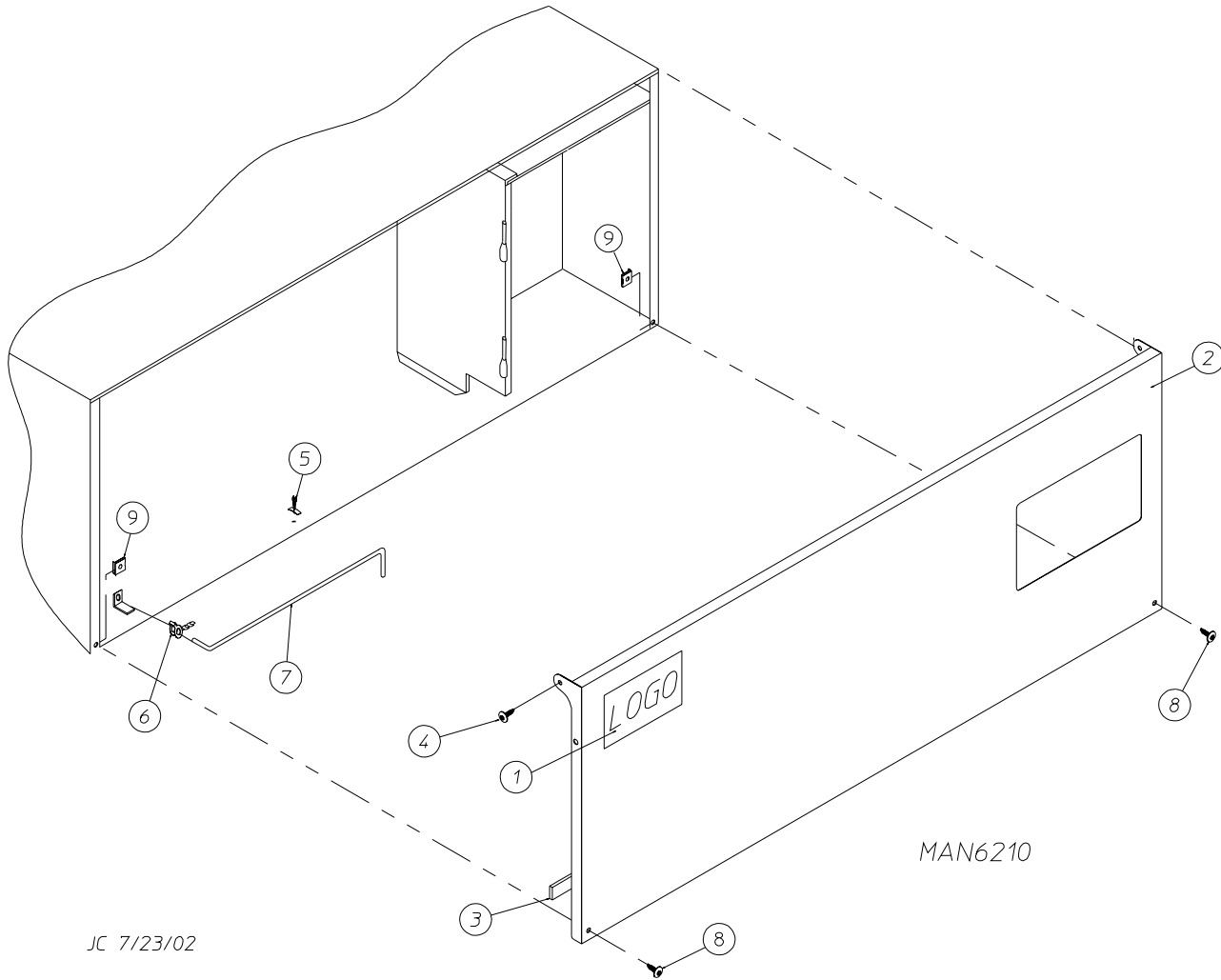

Illus. No.	Part No.	Qty.	Description
1	881053	1	ADC Logo with Tape
	870011	1	Double Sided Tape Kit
2	883550	1	White Control Door Assembly (includes illus. nos. 2 and 3)
	883551	1	Ivory Control Door Assembly (includes illus. nos. 2 and 3)
	883552	1	Coral Blue Control Door Assembly (includes illus. nos. 2 and 3)
3	117604	3	Neoprene Sponge Tape (sold by the foot)
4	150317	2	#10-16 x 3/4" TORX PLUS® BTN Type 1
5	102603	1	Control Door Rod Support Catch
6	102601	1	Control Door Rod Retainer Clip
7	102502	1	Control Door Support Rod
8	150321	2	#10-32 x 1/2" Phillips Machine Screw
9	154011	2	#10-32 Multi-Thread U-Nut

# Coin Control Door Assembly

For Models Mfd. as of July 1, 2002

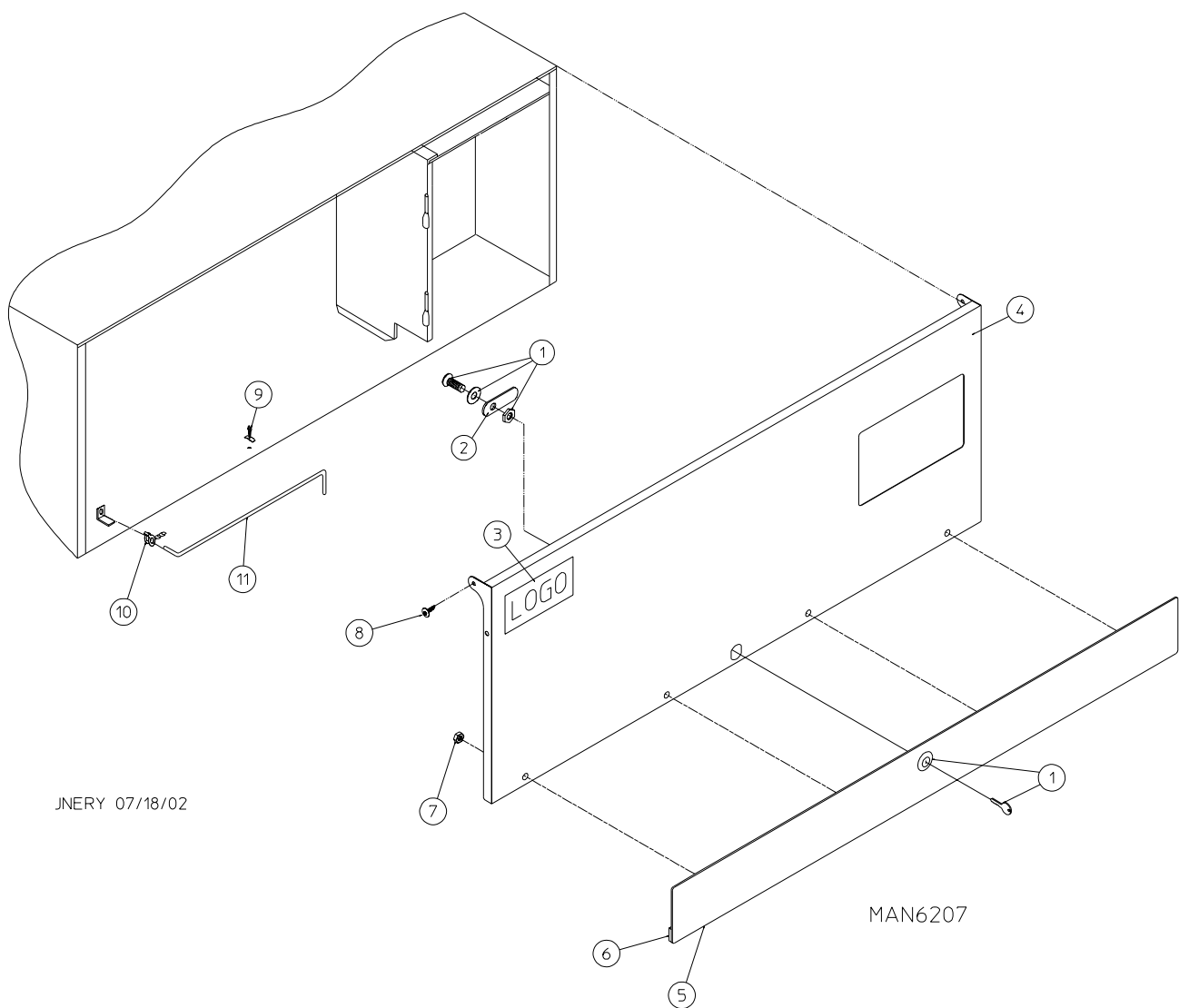

JNERY 07/18/02

MAN6207

Illus. No.	Part No.	Qty.	Description
1	160015	1	High Security Lock Assembly
	160104	1	Key ONLY
2	160016	1	Lock Cam ONLY
3	881053	1	ADC Logo with Tape
4	883477	1	White Control Door Assembly with Black Trim (includes illus. nos. 4 through 7)
	883478	1	Ivory Control Door with Black Trim (includes illus. nos. 4 through 7)
	883549	1	Coral Blue Control Door with Black Trim (includes illus. nos. 4 through 7)
5	883476	1	Black Trim Strip with Lock Hole
6	117604	6	Neoprene Sponge Tape (sold by the foot)
7	152014	4	1/4-20 with 3/4" Free Spin Wash Nut
8	150317	2	#10-16 x 3/4" TORX PLUS® BTN Type 1
9	102603	1	Control Door Rod Support Catch
10	102601	1	Control Door Rod Retainer Clip
11	102502	1	Control Door Support Rod

# Control Door Assembly

For Models Mfd. prior to July 1, 2002

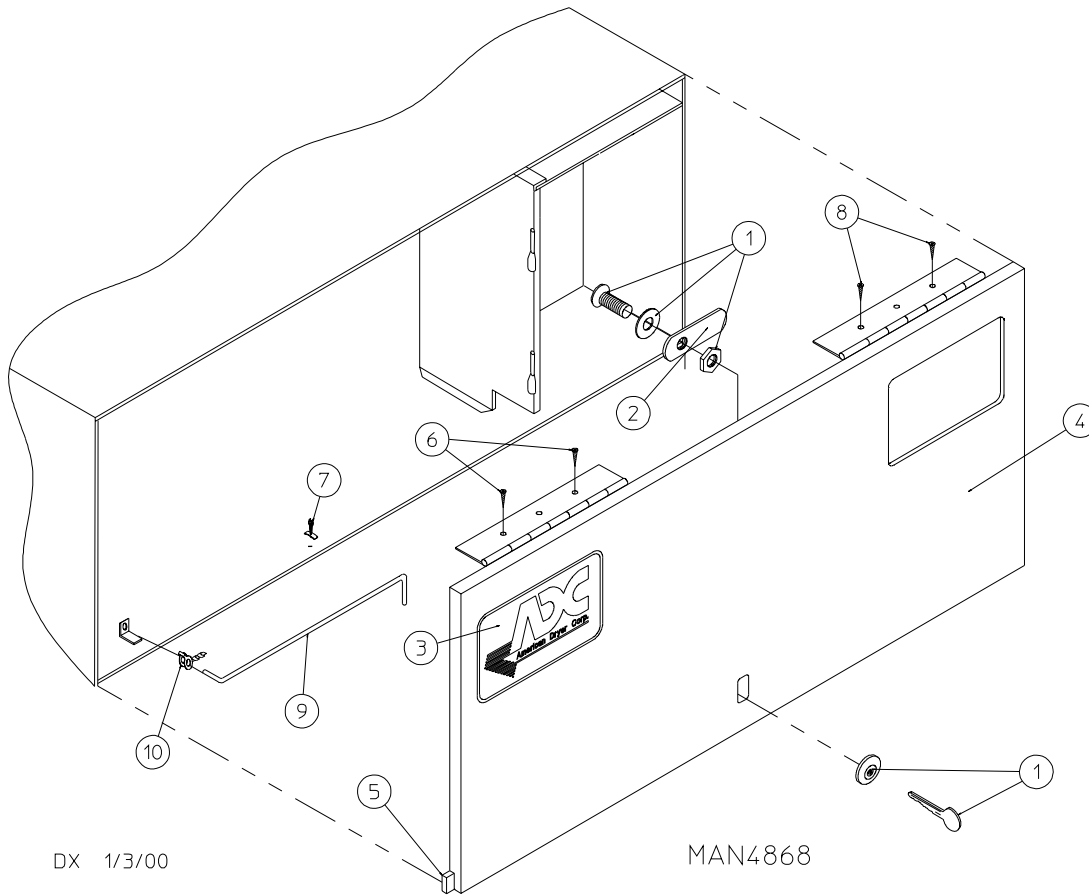

Illus. No.	Part No.	Qty.	Description
1	160015	1	High Security MK-100 Lock Assembly with Key (for coin models Only)
	160017	1	Special Dummy Lock ONLY (for non-coin models Only)
	160104	1	MK-100 Key ONLY
2	160052	1	Lock Cam ONLY
3	881053	1	ADC Logo with Tape
	870011	1	Double Sided Tape Kit
4	882511	1	White High Security Control Door Assembly Less Lock (includes illus. nos. 4 and 5)
	882513	1	Almond "B" High Security Control Door Assembly Less Lock (includes illus. nos. 4 and 5)
	882512	1	Coral Blue High Security Control Door Assembly Less Lock (includes illus. nos. 4 and 5)
	882509	1	Stainless Steel High Security Control Door Assembly Less Lock (includes illus. nos. 4 and 5)
5	117603	3	Noise Suppressor Tape (sold by the foot)
6	150300	2	#10-16 x 1/2" Hex Washer TEK Screw
7	102603	1	Control Door Rod Support Catch
8	150300	2	#10-16 x 1/2" Hex Washer TEK Screw
9	102502	1	Control Door Support Rod
10	102601	1	Control Door Rod Retainer Clip

# Phase 5 Coin Microprocessor Control Panel Assembly

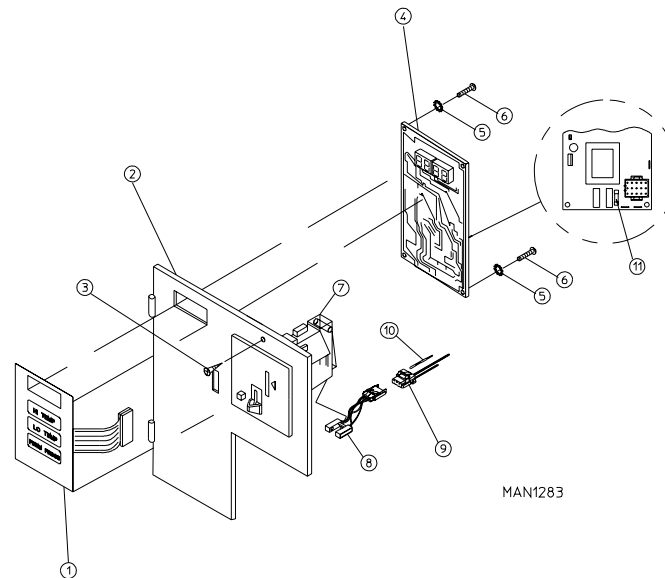

<u>Illus. No.</u>	<u>Part No.</u>	<u>Qty.</u>	<u>Description</u>
1	112526	1	Coin Keypad Label Assembly
2	883537	1	Phase 5 Coin Control Panel Assembly (for models mfd. as of June 25, 2002) (includes illus. nos. 1, 2, and 4 through 6)
	883538	1	Phase 5 Coin Control Panel Assembly with Battery Option (for models mfd. as of June 25, 2002) (includes illus. nos. 1, 2, and 4 through 6)
	883582	1	Phase 5 Coin Control Panel Assembly with Battery Option (for models mfd. prior to June 25, 2002) (includes illus. nos. 1, 2, and 4 through 6)
	883581	1	Phase 5 Coin Control Panel Assembly (for models mfd. prior to June 25, 2002) (includes illus. nos. 1, 2, and 4 through 6)
	883539	1	Coin Control Panel ONLY (for models mfd. as of June 25, 2002)
	883540	1	Coin Control Panel ONLY with Battery Bracket (for models mfd. as of June 25, 2002)
	883580	1	Coin Control Panel ONLY (for models mfd. prior to June 25, 2002)
	883579	1	Coin Control Panel ONLY with Battery Bracket (for models mfd. prior to June 25, 2002)
3	150309	1	#10-16 x 1/2" Hex Head TEK Crimpite Screw
4	137213	1	Phase 5 Coin Controller
	824998	1	Phase 5 Battery Clip
5	153010	2	#6 Star Washer
6	150005	2	#6-32 x 1/4" Phillips Round Head Machine Screw
7	-----	1	Microprocessor Coin Acceptor <b>(refer to Microprocessor Coin Acceptors Listing on page 50)</b>
8	-----	1	Optic Switch ONLY <b>(refer to Microprocessor Coin Acceptors Listing on page 50)</b>
9	137023	1	Optic Switch Connector
10	137021	3	Microprocessor Socket
	880772	1	Single Coin Optical Switch Harness
	122800	1	Microprocessor (female) Pin Extraction Tool
11	136048	1	1/8-Amp (Slo-Blo) Fuse

IMPORTANT: Check label on computer chip to verify correct part number of controller (computer).

# Phase 5 Non-Coin Microprocessor Control Panel Assembly

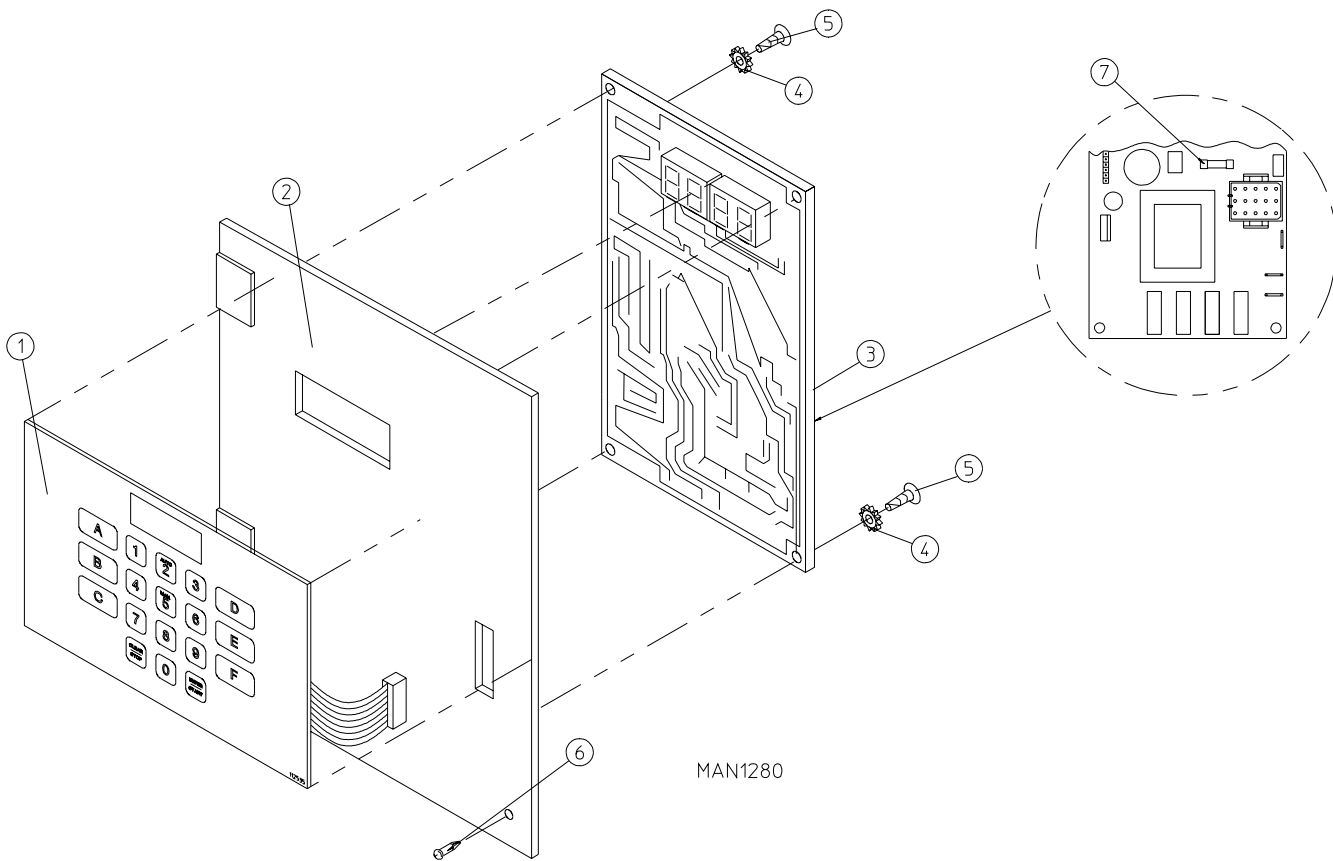

Illus. No.	Part No.	Qty.	Description
1	112535	1	Non-Coin English Keypad Label Assembly
	112276	1	Non-Coin Stick-On Labels (English Only) ... Not Illustrated
	112275	1	3-Language Non-Coin Stick-On Labels (Spanish, Italian, and Hebrew) ... Not Illustrated
	112277	1	3-Language Non-Coin Stick-On Labels (English, Spanish, and Hebrew) ... Not Illustrated
	112278	1	5-Language Non-Coin Stick-On Labels (Italian, Dutch, French, German, and Chinese) ... Not Illustrated
2	801255	1	Phase 5 Microprocessor Control Panel ONLY
	801256	1	Phase 5 Microprocessor Control Panel with Battery Bracket
	801206	1	Phase 5 Non-Coin Non-Reversing Microprocessor Control Panel Assembly Complete (includes illus. nos. 1 through 6)
	801207	1	Phase 5 Non-Coin Reversing Microprocessor Control Panel Assembly Complete (includes illus. nos. 1 through 6)
3	137222	1	Phase 5 Non-Coin Non-Reversing Controller
	137231	1	Phase 5 Non-Coin Reversing Controller
	824998	1	Phase 5 Battery Clip
4	153010	2	#6 Star Washer
5	150005	2	#6-32 x 1/4" Phillips Round Head Machine Screw
6	150309	1	#10-16 x 1/2" Hex Head TEK Crimptite Screw
7	136048	1	1/8-Amp (Slo-Blo) Fuse

**IMPORTANT:** Check label on computer chip to verify correct part number for controller (computer).



# Coin and Non-Coin Control Box Assembly

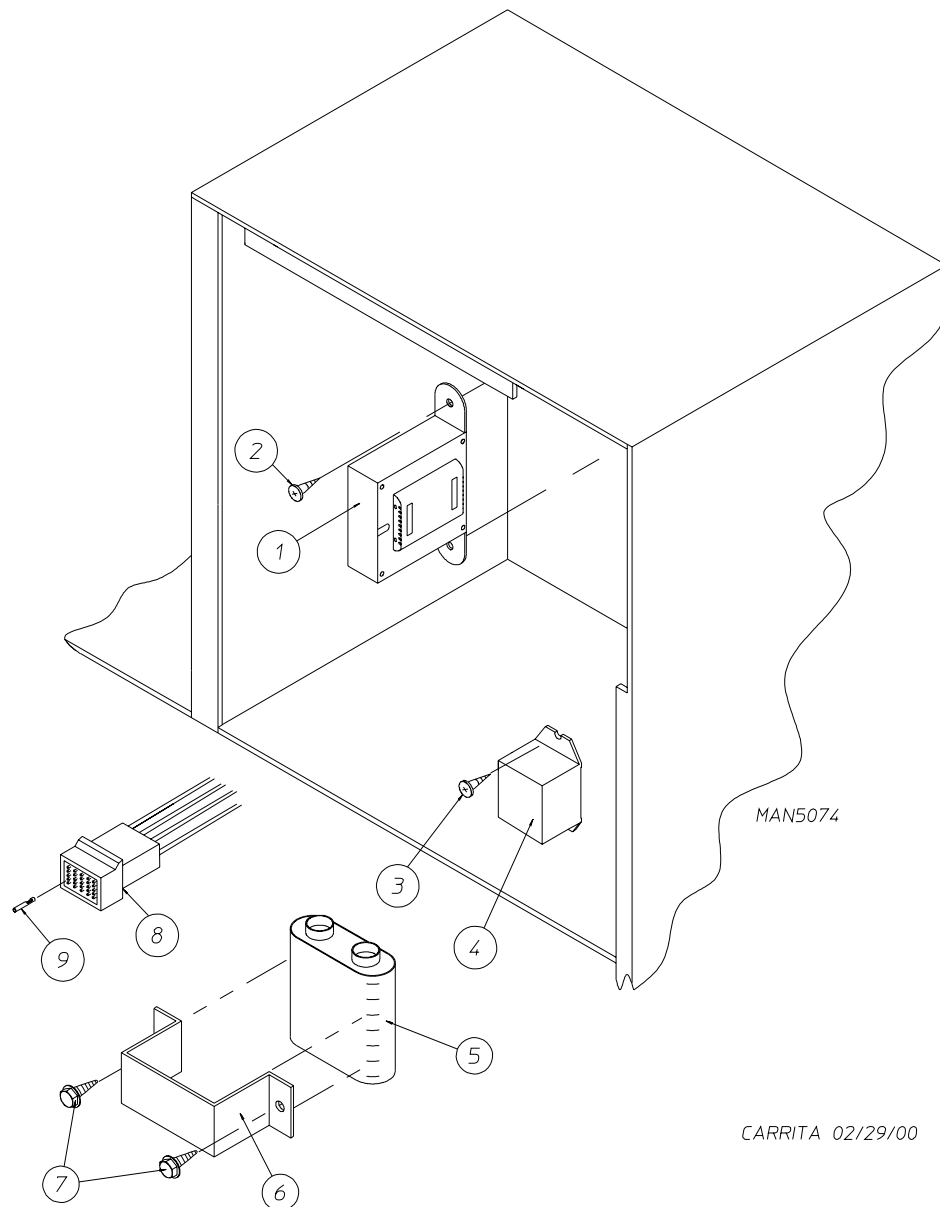

Illus. No.	Part No.	Qty.	Description
1	132002	1	Transformer (for mechanical steam damper models – 208 VAC and higher Only)
2	150300	2	#10-16 x 1/2" Hex Washer TEK Screw
3	150301	2	#8-18 x 7/16" Phillips Pan Head TEK Screw
4	131931	1	Steam Valve Relay – 24 VAC (for mechanical steam damper models Only)
5	137035	1	Motor Capacitor (for mechanical steam damper models Only)
6	323583	1	Capacitor Bracket (for mechanical steam damper models Only)
7	150300	2	#10-16 x 1/2" Hex Washer TEK Screw
8	122641	1	15-Pin Microprocessor Controller (computer) Connector
9	122706	*	Socket Terminal ONLY
—	122801	1	Pin / Socket Extraction Tool

\* As required.

# Coin Vault Assembly

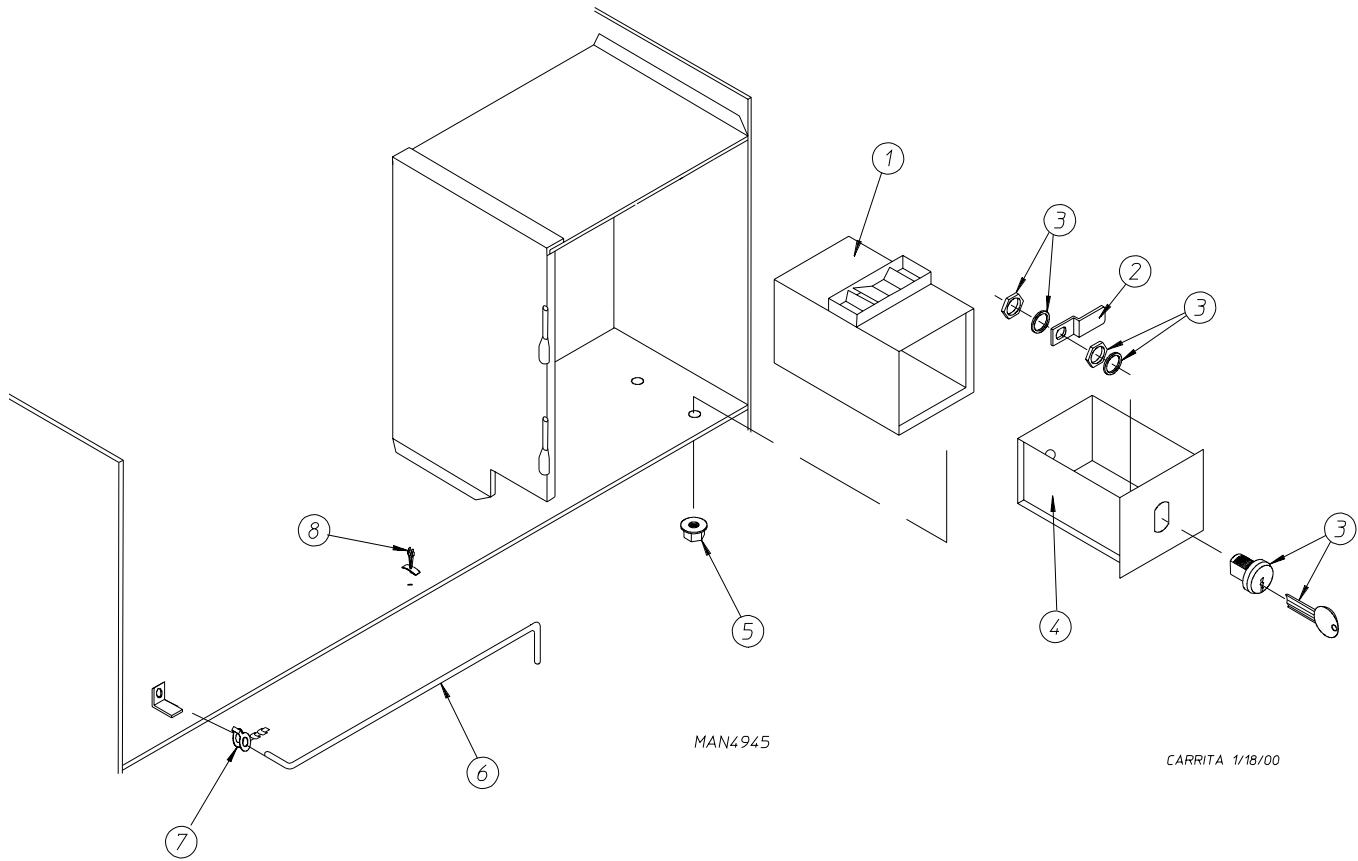

Illus. No.	Part No.	Qty.	Description
1	802112	1	Microprocessor Coin Vault Assembly Complete (includes illus. nos. 1 through 5)
	802117	1	Microprocessor Coin Vault ONLY
	802110	1	Non-Microprocessor Coin Vault Assembly Complete (includes illus. nos. 1 through 5)
	802115	1	Non-Microprocessor Coin Vault ONLY
2	160028	1	Cam for 1/4 Turn Lock
3	875061	1	1/4 Turn Lock with Key and Cam
	160105*	1	1/4 Turn Mer-Pel Key ONLY
4	802020	1	1/4 Turn Coin Box Assembly (includes illus. nos. 2 through 4)
5	152014	4	1/4-20 Free Spin Wash Nut
6	102502	1	Control Door Support Rod
7	102601	1	Control Door Rod Retainer Clip
8	102603	1	Control Door Rod Catch

\* Specify key number when ordering.

# Dual Timer "Tap Touch" Controls

For Models Mfd. as of November 1, 2000

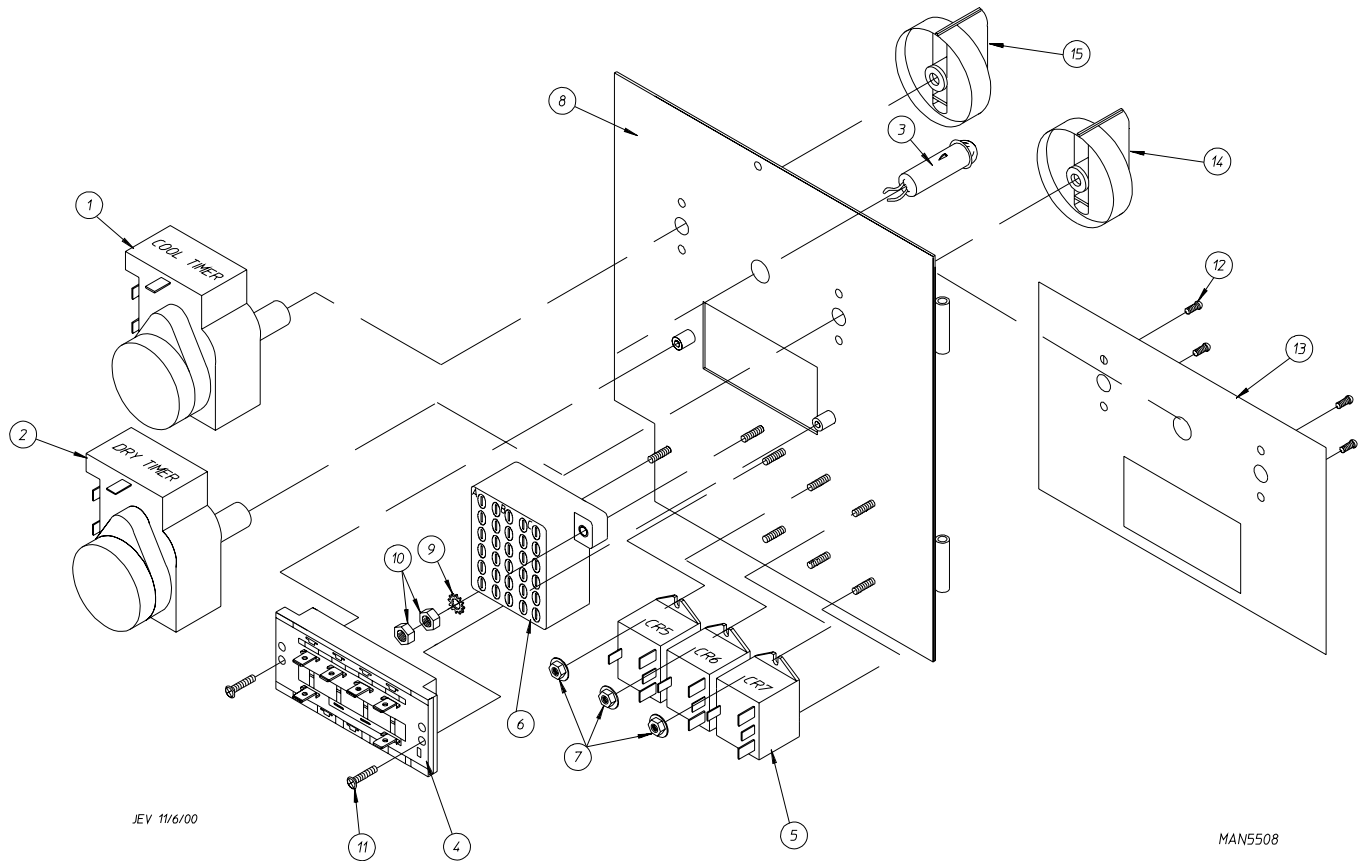

JEV 11/6/00

MAN5508

Illus. No.	Part No.	Qty.	Description
1	824298	1	15 Minute Timer – 24 VAC
2	824299	1	60 Minute Timer – 24 VAC
3	824175	1	Red Pilot Light – 24 VAC
4	122301	1	"Tap Touch" Switch
5	131932	3	Relay SPST 24v
6	120730	1	30-Position Terminal Block
7	151000	6	#6-32 Pal Nut
8	882903	1	Dual Timer Panel Complete (includes illus. nos. 1 through 15)
	850392	–	Dual Timer Panel ONLY
9	153010	2	#6 Star Washer
10	152000	3	#6-32 Hex Nut
11	150207	2	#10-24 x 1/2" Phillips Pan Head Machine Screw
12	150110	4	#8-32 x 1/4" Phillips Round Head Machine Screw
13	112563	1	Dual Timer Panel Overlay
14	124104	1	Pure Touch Knob with Red Pointer
15	124105	1	Pure Touch Knob with Blue Pointer

# Dual Timer Control Panel Assembly

For Models Mfd. prior to November 1, 2000

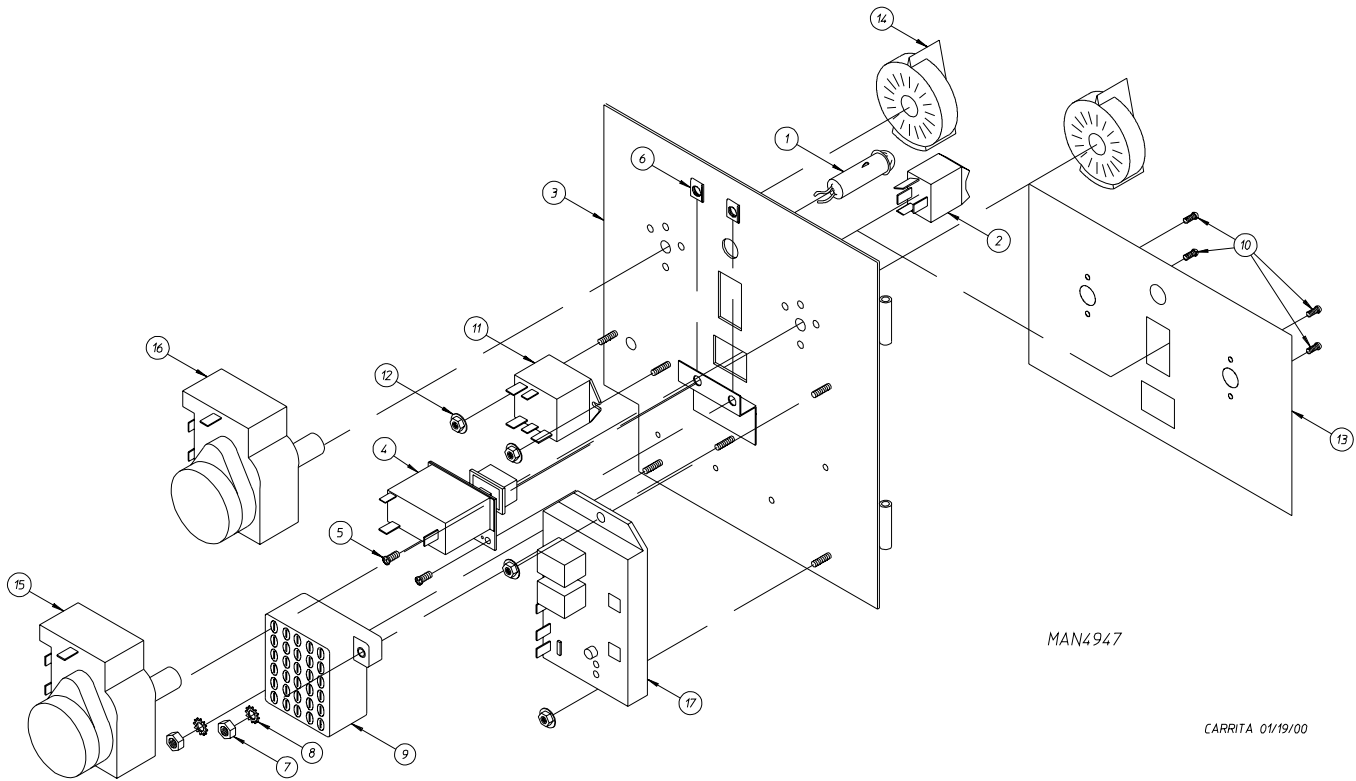

Illus. No.	Part No.	Qty.	Description
1	123005	1	Red Indicator Light – 24 VAC
2	122400	1	Rocker Heat Selector Switch
3	882596	1	Dual Timer Control Panel Assembly Complete – 24 VAC (includes illus. nos. 1 through 16)
	882600	1	Dual Timer Reversing Control Panel Assembly Complete – 24 VAC (includes illus. nos. 1 through 17)
	850456	1	Dual Timer Control Panel ONLY
4	131917	1	Push-To-Start Relay – 24 VAC
5	150207	2	#10-24 x 1/2" Phillips Pan Head Machine Screw
6	154001	2	#10-24 Speed Nut
7	152000	2	#6-32 Hex Nut
8	153010	2	#6 Star Washer
9	120730	1	30-Position Terminal Block
10	150110	4	#8-32 x 1/4" Phillips Round Head Machine Screw
11	131932	1	Dual Timer Relay – 24 VAC
12	151000	4	#6-32 Pal Nut
13	112050	1	Dual Timer Label
14	124103	2	Arrow Timer Knob
15	124025	1	60-Minute Timer – 24 VAC
16	124030	1	15-Minute Timer – 24 VAC
17	132198	1	Reversing Timer – 24 VAC
—	882540	1	Panel Wiring (non-reversing panel) ... Not Illustrated
—	882573	1	Panel Wiring (reversing panel) ... Not Illustrated

# Non-Microprocessor Coin Meter Control Panel Assembly

For Models Mfd. as of January 25, 2002

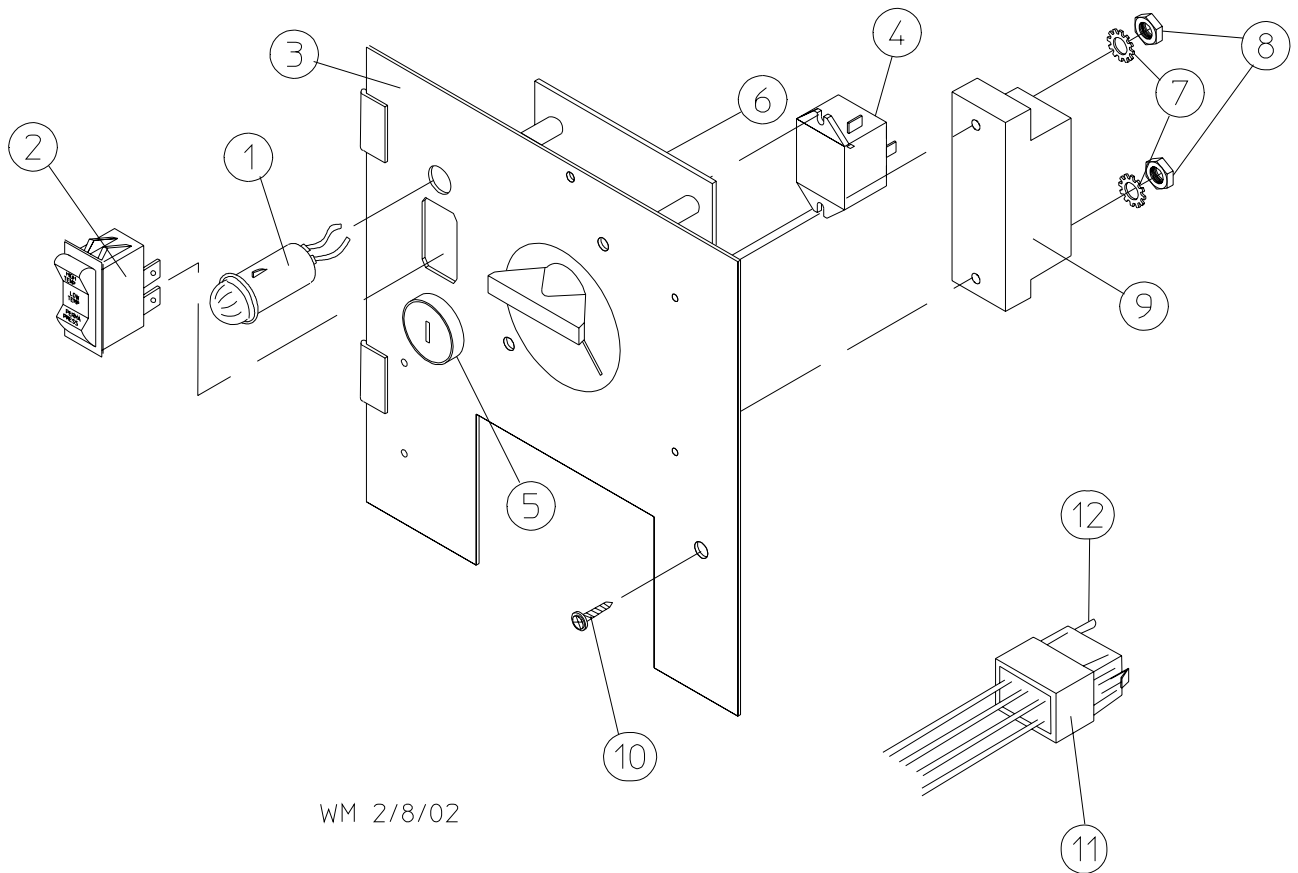

WM 2/8/02

MAN6086

Illus. No.	Part No.	Qty.	Description
1	123005	1	Red Indicator Light – 24 VAC
2	122400	1	Rocker Heat Selector Switch
3	824172	1	Coin Meter Control Panel Assembly Less Coin Meter (includes illus. nos. 2 through 5, 7, and 8)
	824109	1	Coin Meter Control Panel ONLY
4	131932	1	24 VAC Relay
	154001	2	#10-24 Speed Nut (used on P/N: 131932, 24 VAC relay)
5	123225	1	Green Push-To-Start Button
6	125601	1	25¢ Coin Meter – 24 VAC (specify timing)
7	153010	2	#6 Star Washer
8	152016	2	#4-40 Hex Nut
9	120712	1	12-Position Terminal Block
10	150300	1	#10-16 x 1/2" Hex Washer TEK Screw
11	122602	1	9-Pin Connector
12	122700	7	Pin Terminal
—	122801	1	Pin Extraction Tool

NOTE: For Coin Meter Replacement Parts refer to page 51.

# Non-Microprocessor Coin Meter Control Panel Assembly

For Models Mfd. prior to January 25, 2002

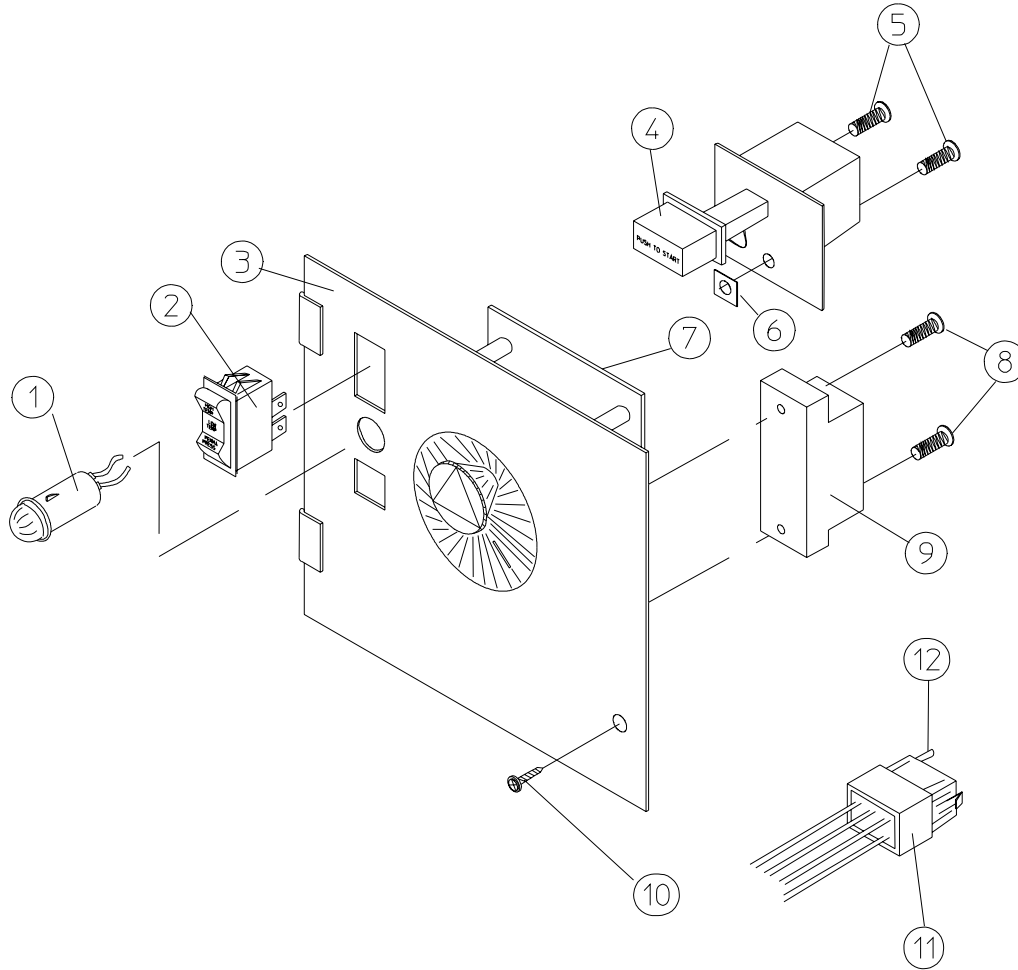

MAN1625

<u>Illus. No.</u>	<u>Part No.</u>	<u>Qty.</u>	<u>Description</u>
1	123005	1	Red Indicator Light – 24 VAC
2	122400	1	Rocker Heat Selector Switch
3	824020	1	Coin Meter Control Panel Assembly Complete – 24 VAC (includes illus. nos. 1 through 6 and 8 through 12)
	800054	1	Coin Meter Control Panel ONLY
4	131917	1	Push-To-Start Relay – 24 VAC
5	150207	2	#10-24 x 1/2" Round Head Machine Screw
6	154001	2	#10-24 Speed Nut
7*	125601	1	25¢ Coin Meter – 24 VAC (specify timing)
8	150303	2	#4 x 3/4" Pan Head "A" Screw
9	120712	1	12-Position Terminal Block
10	150309	1	#10-16 x 1/2" Hex Head TEK Crimp Screws
11	122602	1	9-Pin Connector
12	122700	9	Pin Terminal
—	122801	1	Pin / Socket Extraction Tool

\* Consult factory for coin meters not listed.

**NOTE: For Coin Meter Replacement Parts refer to page 51.**

# Front Panel Assembly

For Models Mfd. with Steel Main Door

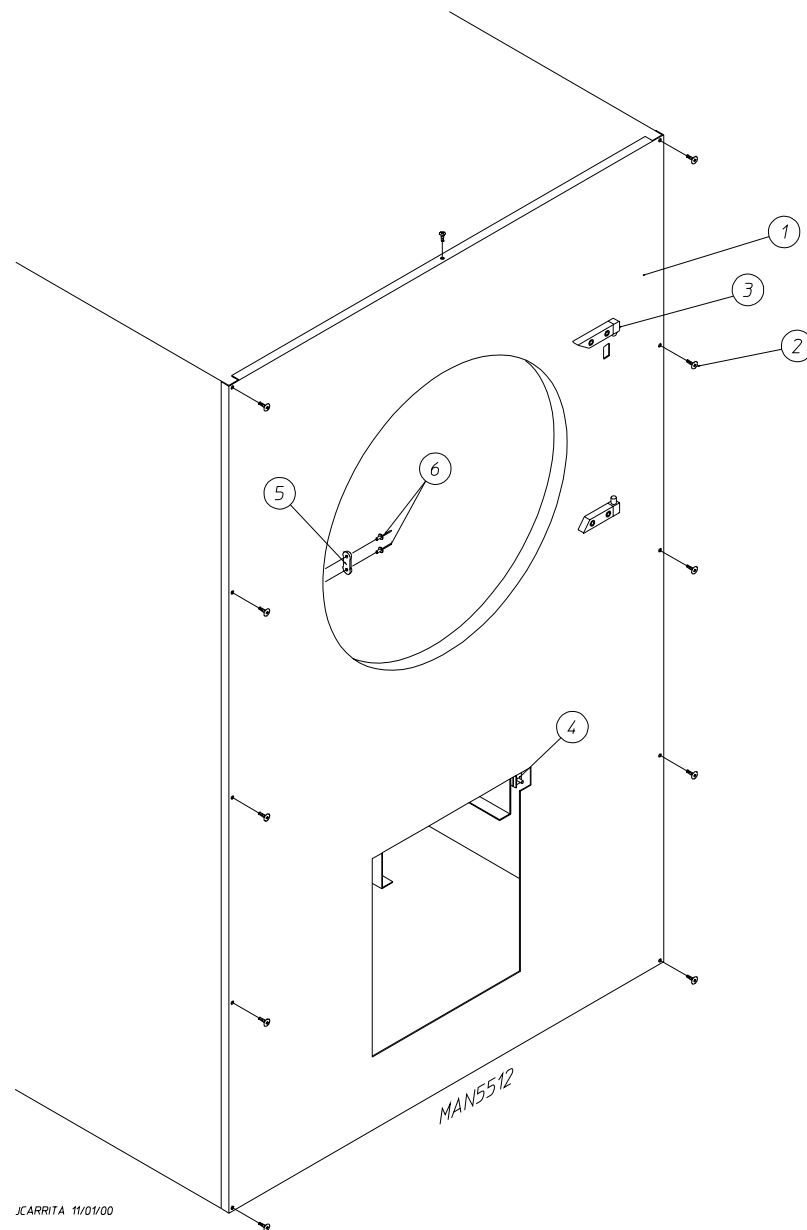

JCARRITA 11/01/00

Illus. No.	Part No.	Qty.	Description
1	883137	1	White Front Panel Assembly (includes illus. nos. 1, 5, and 6)
	883138	1	Coral Blue Front Panel Assembly (includes illus. nos. 1, 5, and 6)
	883139	1	Ivory Front Panel Assembly (includes illus. nos. 1, 5, and 6)
2	150313	11	#10-16 x 1/2" TORX PLUS® BTN Type 1
	150318	1	25 IP TORX PLUS® Bit 1/4 Hex (for removal of TORX® head screw)
3	_____	1	Main Door Hinge
4	_____	1	Lint Drawer Switch <b>(refer to Lint Drawer / Lint Drawer Switch Assemblies on page 21)</b>
5	170330	1	Friction Door Latch
6	154215	2	5/32" Pop Rivet

# Front Panel Assembly

For Models Mfd. with Plastic Main Door

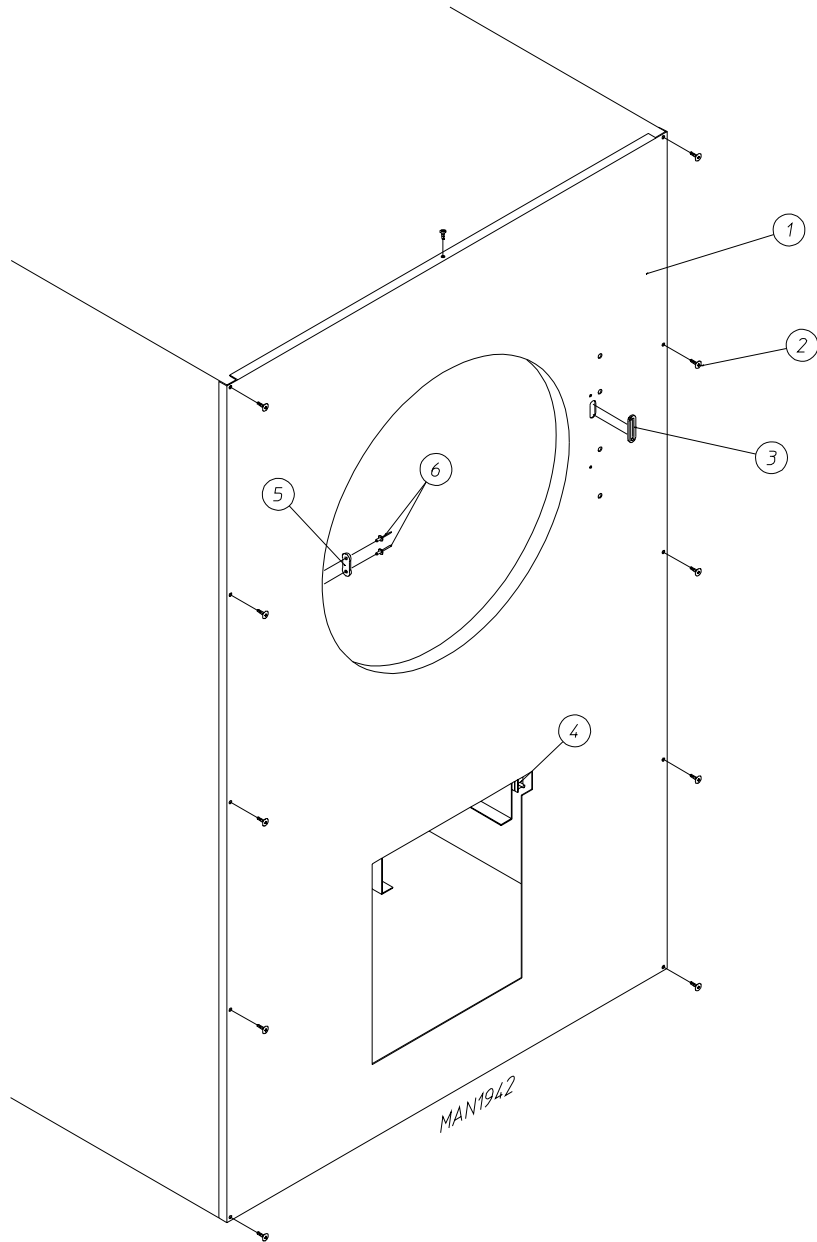

<u>Illus. No.</u>	<u>Part No.</u>	<u>Qty.</u>	<u>Description</u>
1	882525	1	White Right Hand Front Panel Assembly (includes illus. nos. 1, 3, 5, and 6)
	882527	1	Almond "B" Right Hand Front Panel Assembly (includes illus. nos. 1, 3, 5, and 6)
	882528	1	Coral Blue Right Hand Front Panel Assembly (includes illus. nos. 1, 3, 5, and 6)
2	150309	11	#10-16 x 1/2" Hex Head TEK Crimptite Screw
3	121405	1	Rubber Grommet
4	-----	1	Lint Drawer Switch <b>(refer to Lint Drawer / Lint Drawer Switch Assemblies on page 21)</b>
5	170330	1	Friction Door Latch
6	154215	2	5/32" Pop Rivet



# Main Door "Steel" Assembly

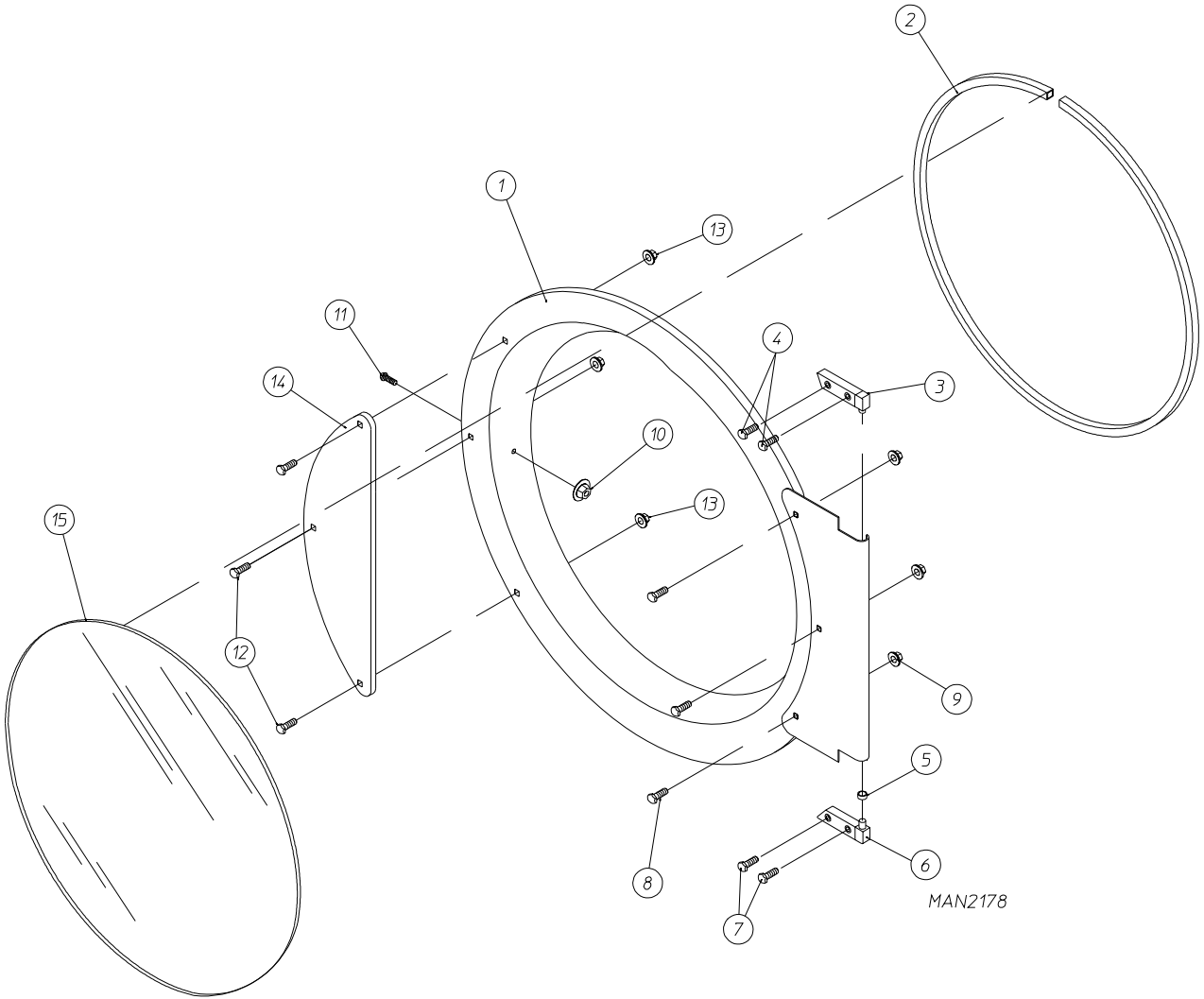

Illus. No.	Part No.	Qty.	Description
1	881150	1	Black Main Door Assembly Complete (includes illus. nos. 1, 2, and 8 through 15)
2	102354	1	Door Gasket
	170731	1	Black Gasket Adhesive (10.7 oz. cartridge)
3	881152	1	Black Top Hinge Block Assembly (includes illus. nos. 3 and 4)
4	150445	2	1/4-20 x 3/4" Black Cap Head Setscrew
5	153031	1	1/4" Nylon Washer
6	881151	1	Black Bottom Hinge Block Assembly (includes illus. nos. 5 through 7)
7	150445	2	1/4-20 x 3/4" Black Cap Head Setscrew
8	150683	3	1/4-20 x 5/8" Black Carriage Bolt
9	152014	3	1/2-20 Free Spin Wash Nut
10	151010	1	#10-32 Black Hex Acorn Nut
11	150120	1	Door Latch Screw
12	150683	3	1/4-20 x 5/8" Black Carriage Bolt
13	152014	3	1/2-20 Free Spin Wash Nut
14	881210	1	Black Main Door Handle ONLY
15	102211	1	20-7/16" Door Glass
	170731	1	Black Glass Adhesive (10.3 oz. cartridge)

# Plastic Main Door Assembly

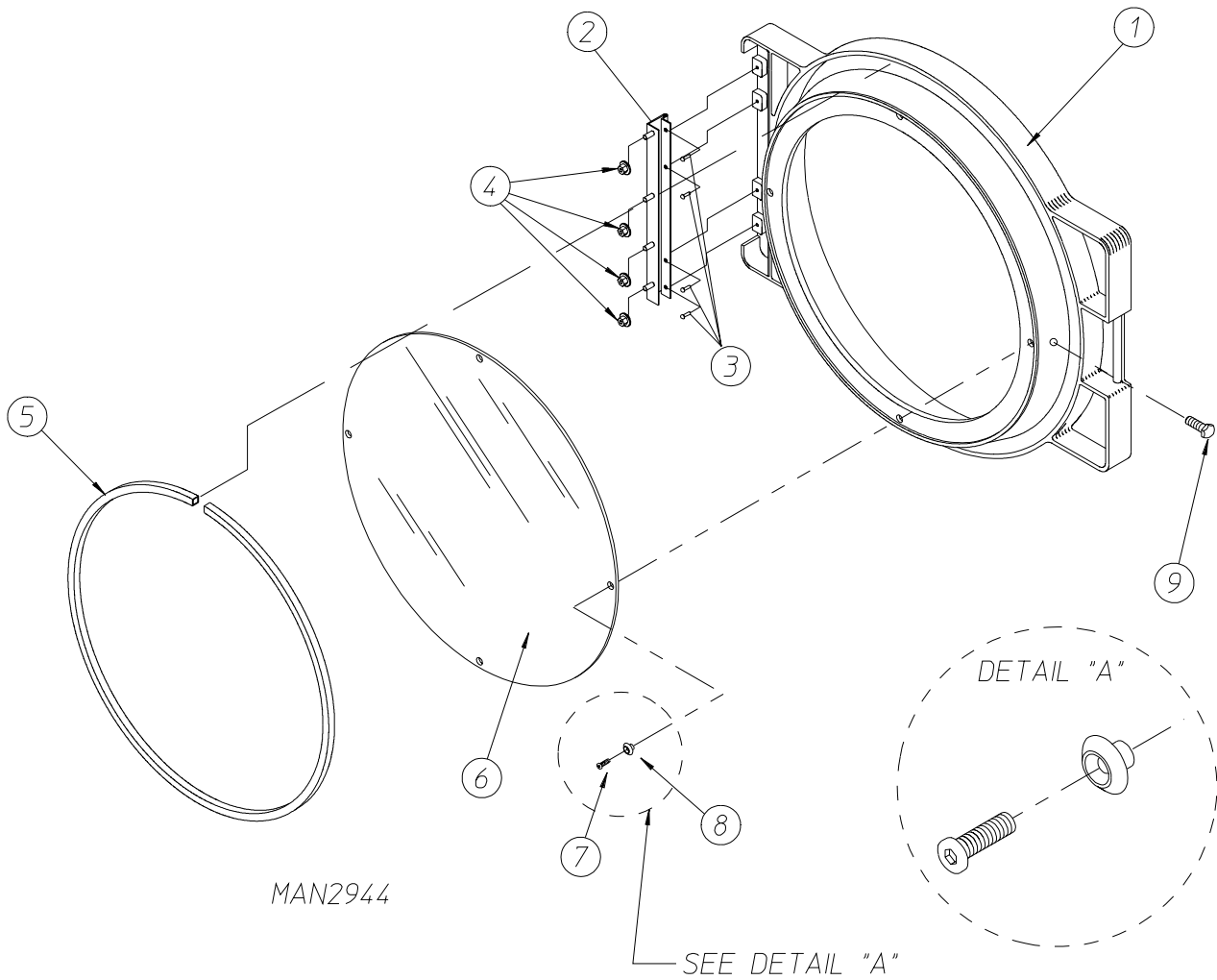

Illus. No.	Part No.	Qty.	Description
1	881422	1	Black Plastic Main Door Assembly Complete with Mechanical Fasteners (includes illus. nos. 1 and 5 through 9)
2	800448	1	12-1/2" Stainless Steel Main Door Hinge Assembly
3	150410	4	#10-24 x 3/8" Phillips Pan Head Taptite Screw
4	152014	4	1/4-20 Free Spin Wash Nut
5	102349	1	Main Door Gasket
6	102212	1	20-7/16" Door Glass with 4 Holes
	170730	1	Main Door Gasket / Glass Adhesive (10.3 oz. cartridge)
7	150448	4	1/2" Stainless Steel Flat Head Allen Screw
8	170319	4	Door Glass (Nylon) Spacer
9	150431	1	Main Door Latch Screw (#10 x 7/16" Dome Hex Head Screw)

# Main Door Switch Assembly

For Models Mfd. with Steel Main Door

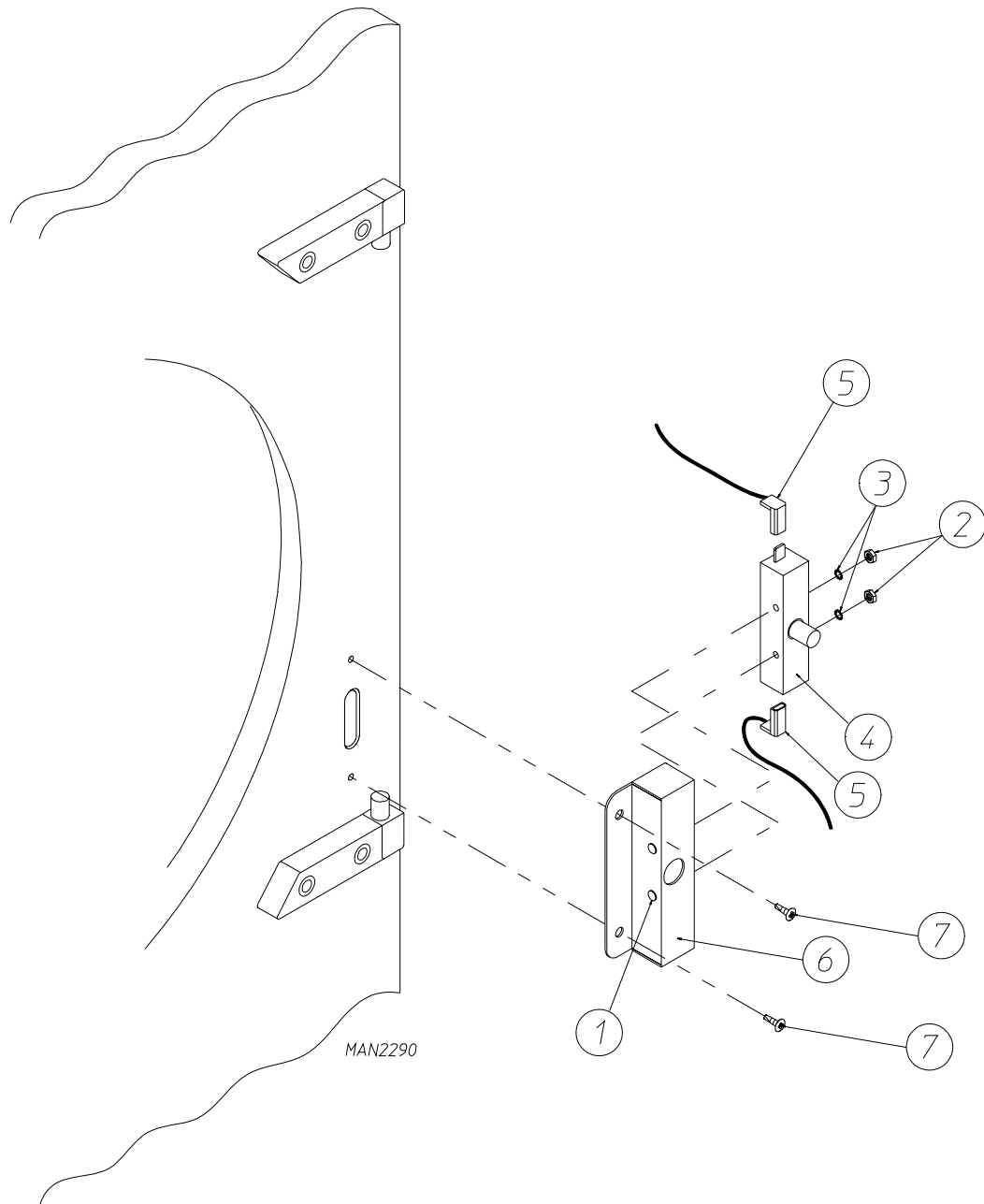

<u>Illus. No.</u>	<u>Part No.</u>	<u>Qty.</u>	<u>Description</u>
1	150006	2	#6-32 x 7/8" Phillips Pan Head Machine Screw
2	152013	2	#6-32 Hex Nut
3	153010	2	#6 Star Washer
4	137005	1	Door Switch
5	122636	2	Flag Terminal
6	881211	1	Black Main Door Switch Housing ONLY
	881153	1	Black Main Door Switch Housing Complete (includes illus. nos. 1 through 4 and 6)
7	150301	2	#8-18 x 7/16" Phillips Pan Head TEK Screw

# Main Door Switch

For Models Mfd. with Plastic Main Door

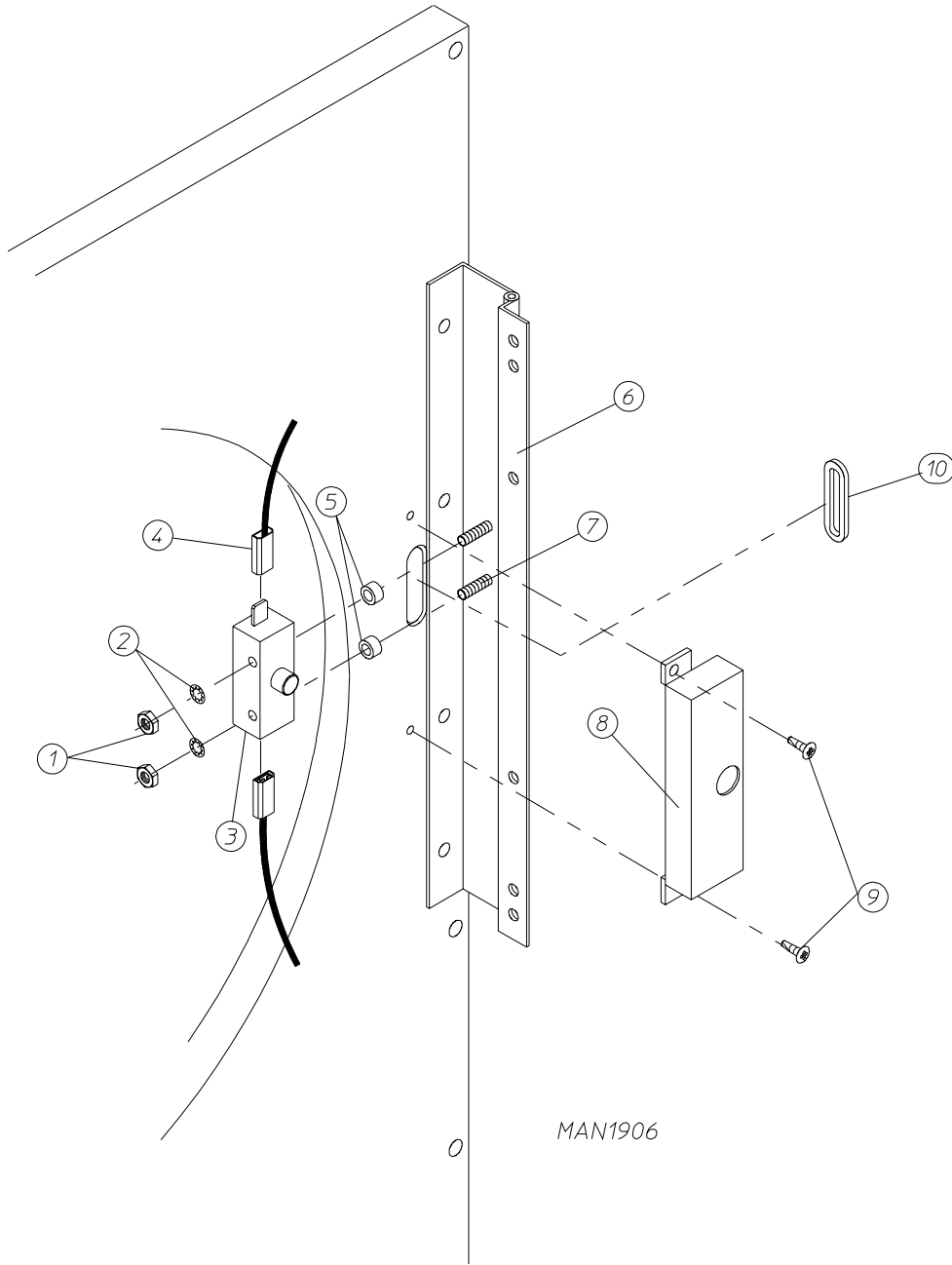

Illus. No.	Part No.	Qty.	Description
1	152013	2	#6-32 Hex Nut
2	153008	2	#6 Lock Washer
3	137005	1	Single Pole Door Switch
4	121028	2	Insulated Female Terminal
5	154281	2	3/8" Standard Nylon Spacer
6	800448	1	12-1/2" Stainless Steel Main Door Hinge Assembly (includes illus. nos. 6 and 7)
7	153565	2	#6-32 x 1" Self-Clinching Stud
8	881246	1	Main Door Switch Housing
9	150201	2	#10-32 x 1/4" Phillips Pan Head Screw
10	121405	1	Rubber Grommet

# Lint Drawer / Lint Drawer Switch Assemblies

For Models Mfd. prior to August 10, 2000 and as of April 19, 2003

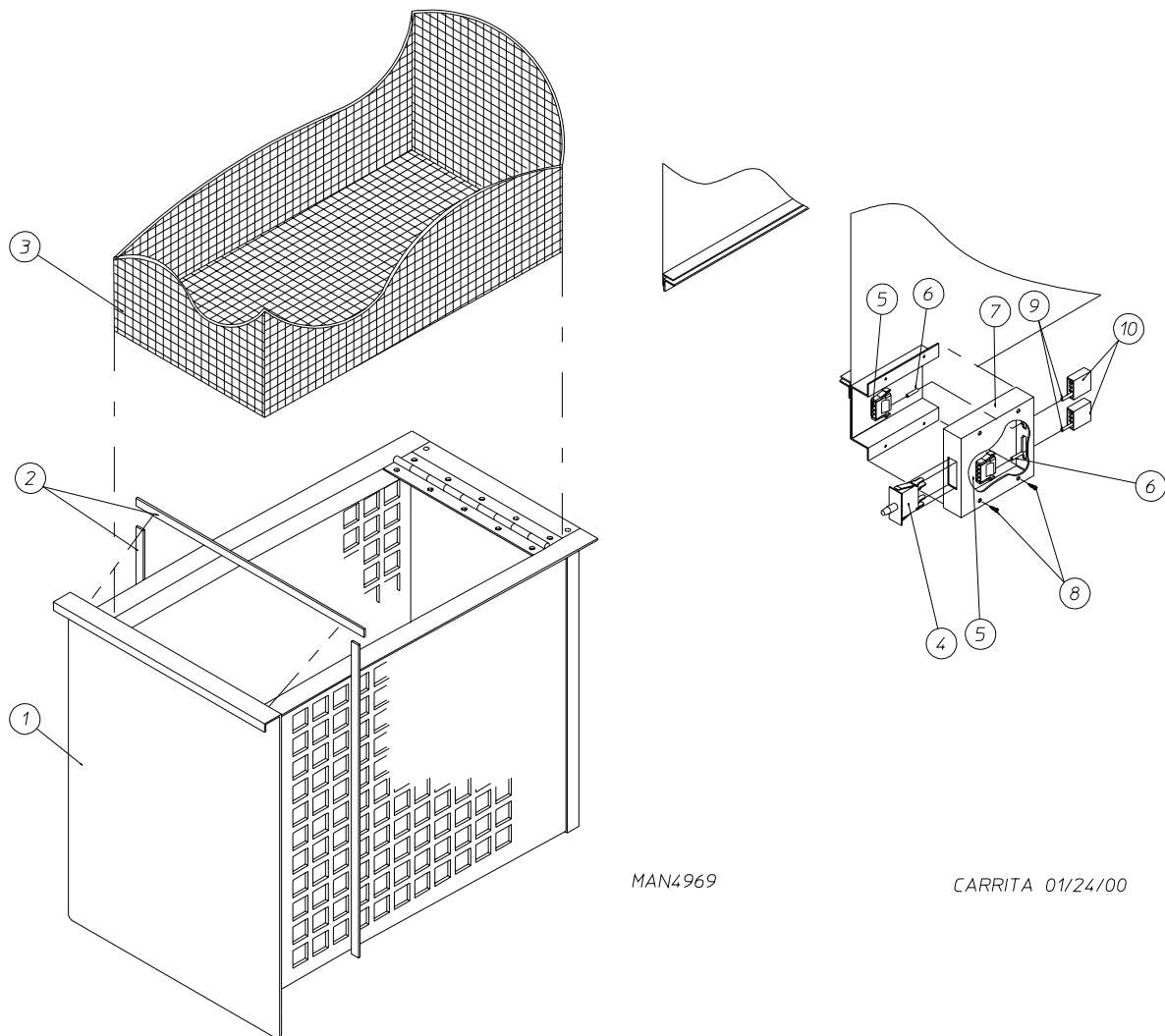

MAN4969

CARRITA 01/24/00

<u>Illus. No.</u>	<u>Part No.</u>	<u>Qty.</u>	<u>Description</u>
1	882629	1	White Lint Drawer Assembly (includes illus. nos. 1 and 2)
	882634	1	Almond "B" Lint Drawer Assembly (includes illus. nos. 1 and 2)
	882628	1	Coral Blue Lint Drawer Assembly (includes illus. nos. 1 and 2)
2	117605	5	Neoprene Sponge Tape (sold by the foot)
3	108225	1	Lint Screen Assembly
4	122116	1	Lint Drawer Switch
5	122605	2	4-Pin Socket Connector
6	122701	4	Socket Terminal
	122801	1	Pin / Socket Extraction Tool
7	800478	1	Lint Drawer Switch Box Assembly (includes illus. nos. 4 through 7)
	304136	1	Lint Drawer Switch Box ONLY
8	150301	2	#8-18 x 7/16" Phillips Pan Head TEK Screw
9	122700	4	Pin Terminal
10	122604	2	4-Pin Connector

# Lint Drawer / Lint Drawer Switch Assemblies

For Models Mfd. between August 10, 2000 and April 18, 2003

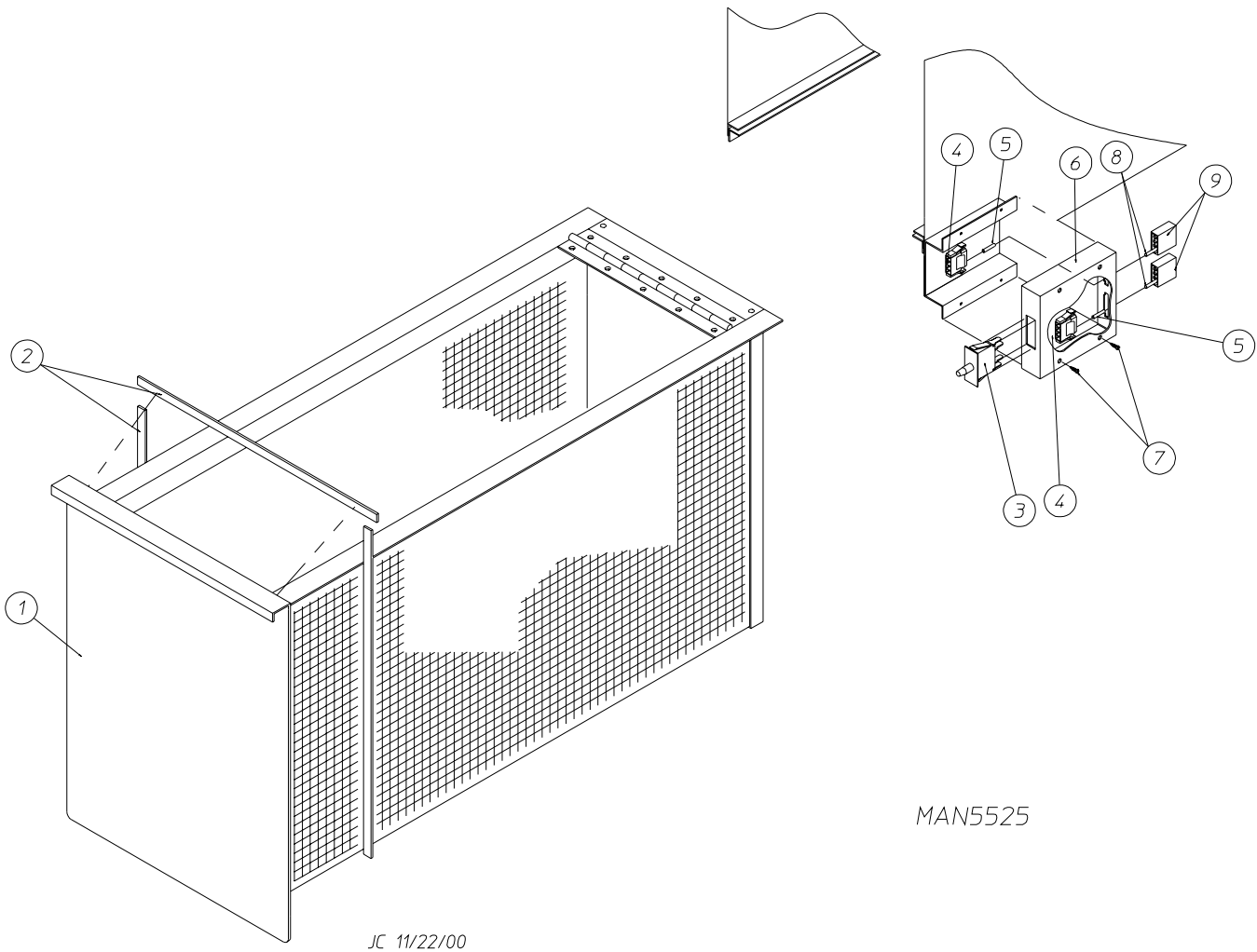

MAN5525

JC 11/22/00

Illus. No.	Part No.	Qty.	Description
1	883161	1	White Lint Drawer Assembly (includes illus. nos. 1 and 2)
	883162	1	Coral Blue Lint Drawer Assembly (includes illus. nos. 1 and 2)
	883163	1	Ivory Lint Drawer Assembly (includes illus. nos. 1 and 2)
2	117605	5	Neoprene Sponge Tape (sold by the foot)
3	122116	1	Lint Drawer Switch
4	122605	2	4-Pin Socket Connector
5	122701	4	Socket Terminal
	122801	1	Pin / Socket Extraction Tool
6	818087	1	Lint Drawer Switch Box Assembly (includes illus. nos. 3 through 6)
	304136	1	Lint Drawer Switch Box Cover ONLY
7	150301	2	#8-18 x 7/16" Phillips Pan Head TEK Screw
8	122700	4	Pin Terminal
9	122604	2	4-Pin Connector

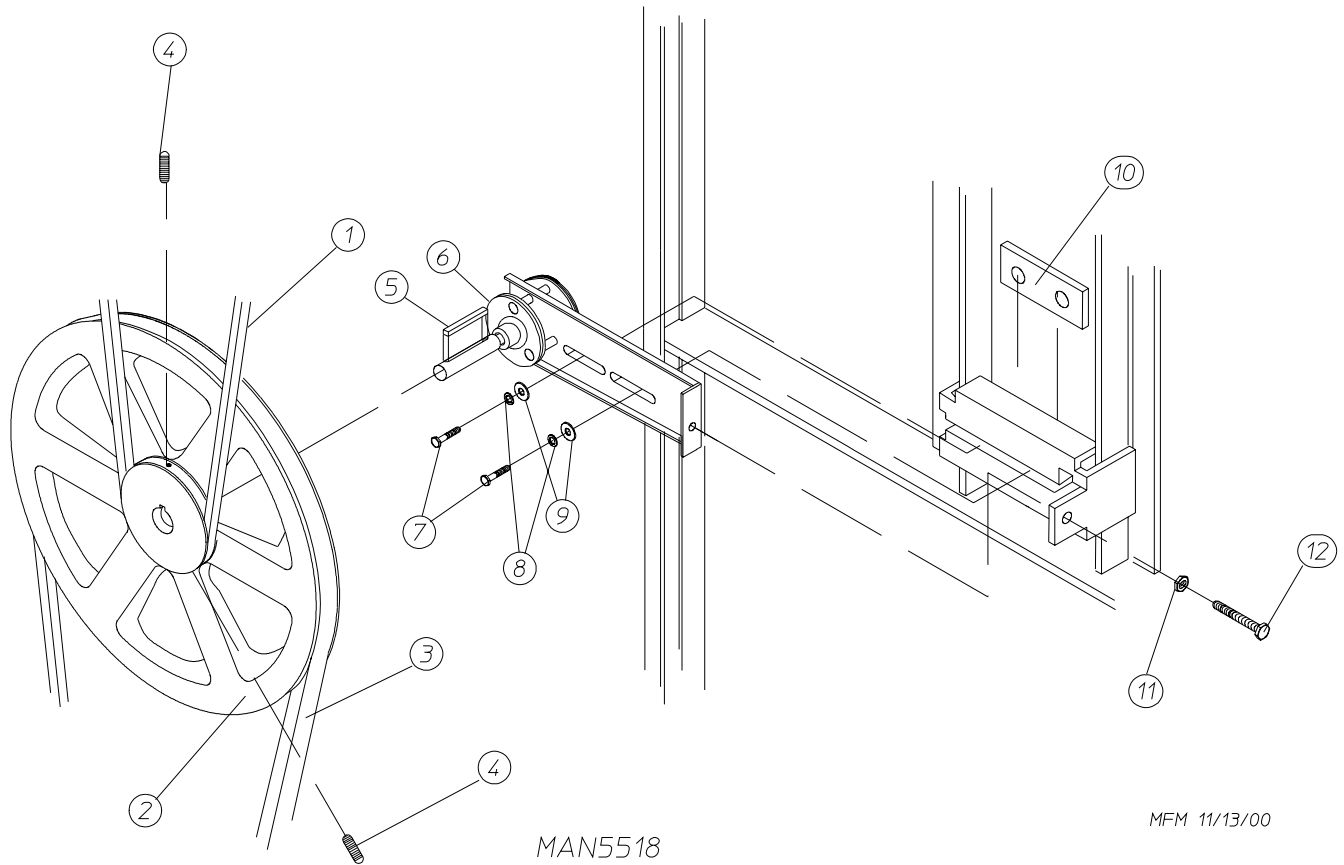

Illus. No.	Part No.	Qty.	Description
1	100100	1	5L-660 V-Belt (tumbler to idler) For Non-Reversing Models ONLY
	100108	1	5L-680 V-Belt (tumbler to idler) For Reversing Models ONLY
2	101129	1	9" x 2-1/2" Compound Pulley
3	100105	1	4L-520 V-Belt For Non-Reversing Models ONLY
	100112	1	4L-610 V-Belt (idler to motor) For Reversing Models ONLY
4	154301	2	5/16-18 x 1" Allen Setscrew
5	100705	1	3/16" x 3/16" x 1-3/8" Key
6	882576	1	Idler Bearing Assembly Complete (includes illus. nos. 5 through 12)
7	150617	2	3/8-16 x 1" Hex Head Machine Bolt
8	153005	2	3/8" Lock Washer
9	153004	2	3/8" Flat Washer
10	801009	1	Idler Square Washer
11	152004	1	5/16-18 Hex Nut
12	150509	1	5/16-18 x 3" Hex Head Machine Bolt

# Tumbler Bearing Assembly

For Models Mfd. as of July 17, 2000

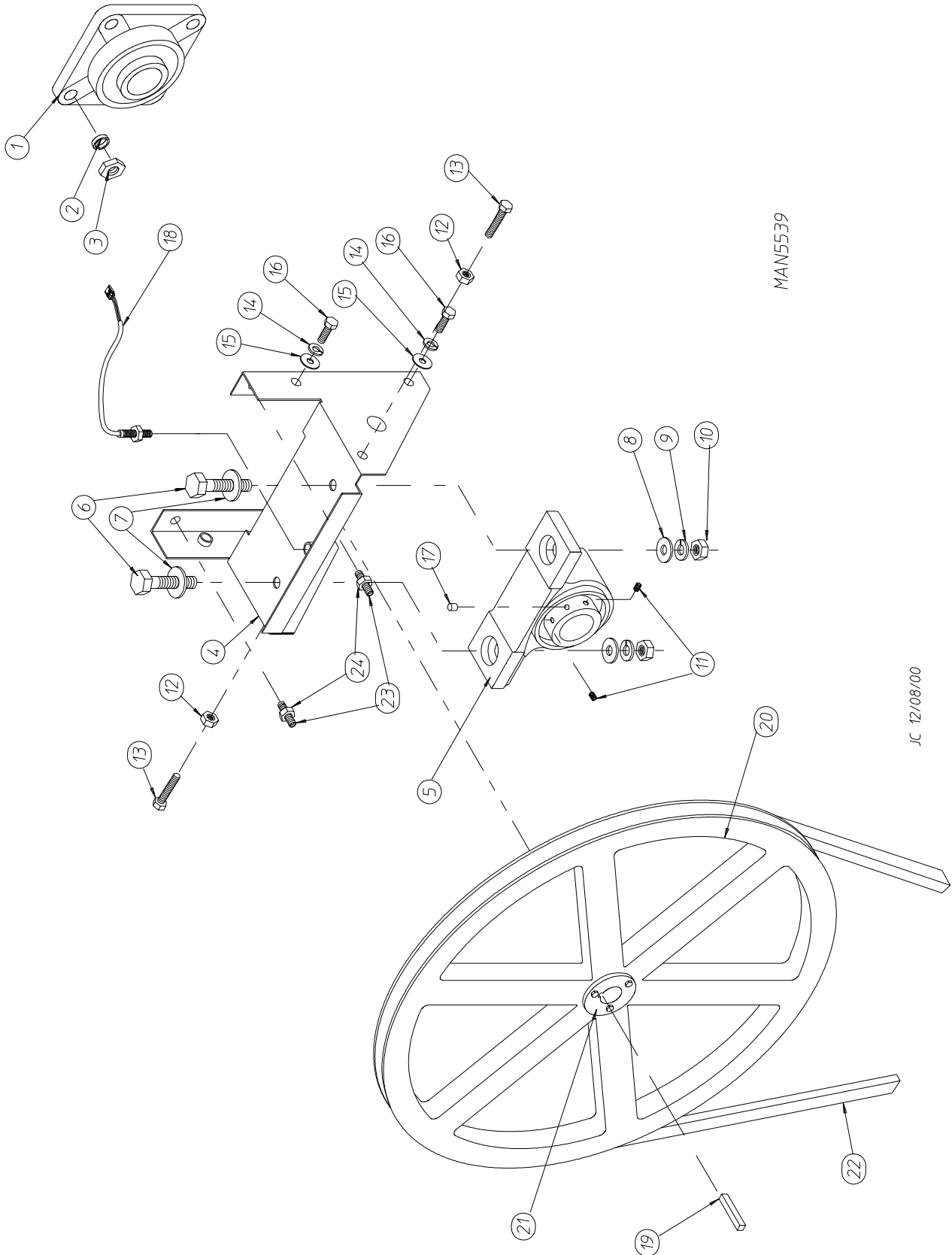

MAN5539

JC 12/08/00



# Tumbler Bearing Assembly

For Models Mfd. as of July 17, 2000

<u>Illus. No.</u>	<u>Part No.</u>	<u>Qty.</u>	<u>Description</u>
1	880220	1	1-3/4" Flange Bearing
2	153025	4	9/16" Lock Washer
3	152050	4	9/16-12 Hex Nut
4	882544	1	Pillow Block Bearing Assembly Complete (includes illus. nos. 4 through 17)
	882545	1	Pillow Block Bearing Assembly Complete with Rotational Sensor (includes illus. nos. 4 through 18)
	882543	1	Pillow Block Bearing Platform ONLY
5	880202	1	1-3/8" Pillow Block Bearing
	880779	1	1-3/8" Pillow Block Bearing (for reversing models Only)
6	150601	2	3/8-16 x 2" Hex Bolt
7	153004	2	3/8" Flat Washer
8	153004	2	3/8" Flat Washer
9	153005	2	3/8" Lock Washer
10	152005	2	3/8-16 Hex Nut
11	154326	2	5/16-24 x 3/8" Setscrew
12	152004	2	5/16-18 Hex Nut
13	150621	2	5/16-18 x 1-1/2" Tap Bolt
14	153002	4	5/16" Lock Washer
15	153004	6	3/8" Flat Washer
16	150501	4	5/16-18 x 3/4" Tap Bolt
17	102120	1	Sintered 8 Magnet (for reversing models Only)
18	824807	1	Rotational Sensor Assembly
19	100735	1	Shaft Key (for reversing models Only)
20	101100	1	18" Pulley (for non-reversing models Only)
	101118	1	18-3/4" Pulley (for reversing models Only)
21	101110	1	1" Taper Lock Bushing (for reversing models Only)
22	100100	1	5L-660 V-Belt (tumbler to idler) for Non-Reversing Models ONLY
	100108	1	5L-680 V-Belt (tumbler to idler)
23	150610	2	5/16-18 x 1-1/2 Allen Setscrew
24	152004	2	5/16-18 Hex Nut

# Tumbler Bearing Assembly

For Models Mfd. prior to July 17, 2000

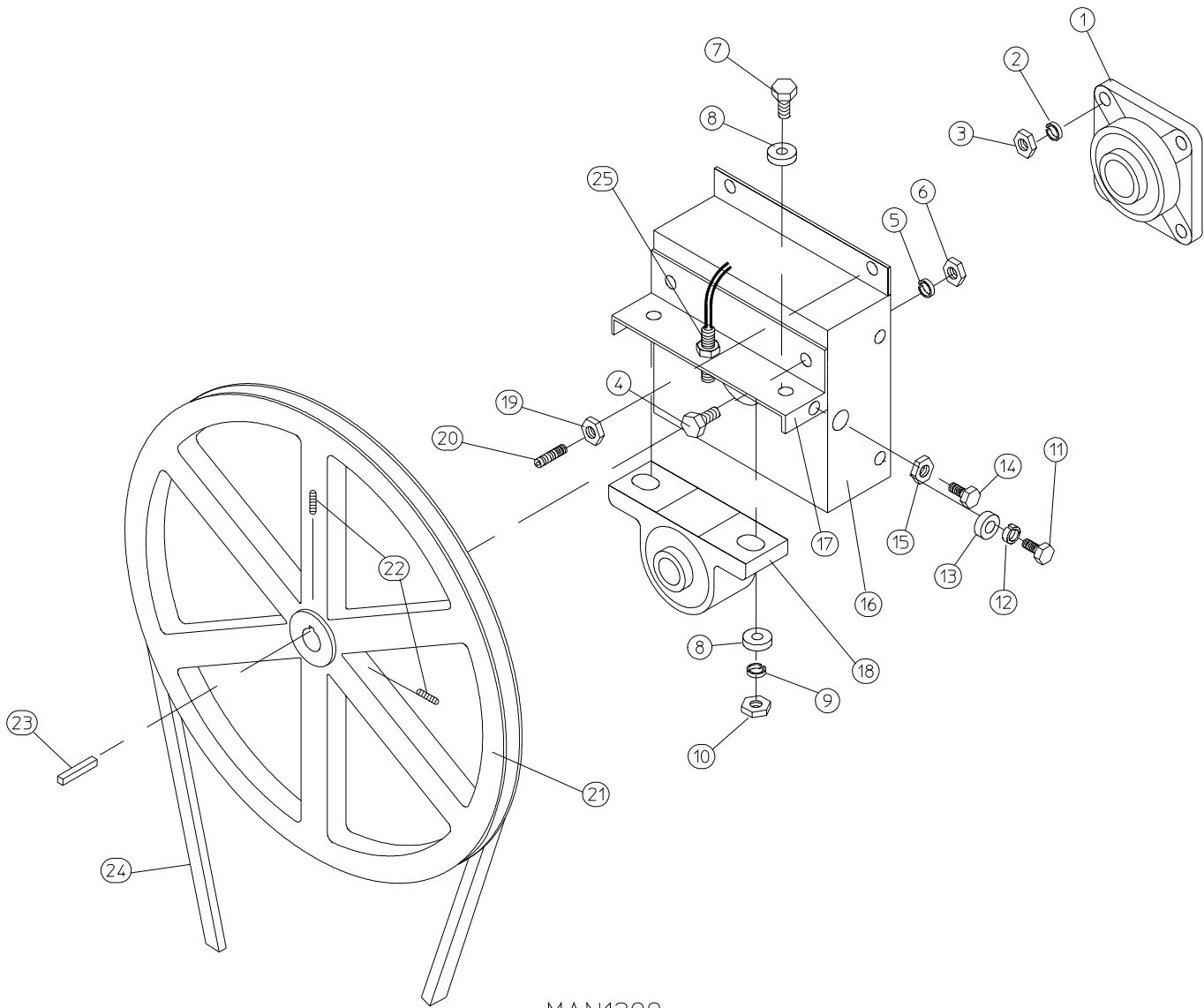

MAN1299

# Tumbler Bearing Assembly

For Models Mfd. prior to July 17, 2000

<u>Illus. No.</u>	<u>Part No.</u>	<u>Qty.</u>	<u>Description</u>
1	880220	1	1-3/4" Flange Bearing with Nylock Setscrews
2	153025	4	9/16" Lock Washer
3	152050	4	9/16-12 Hex Nut
4	150508	2	3/8-16 x 3/4" Hex Head Machine Bolt
5	153005	2	3/8" Lock Washer
6	152005	2	3/8-16 Hex Nut
7	150600	2	3/8-16 x 1-1/2" Hex Head Machine Bolt
8	153004	*	3/8" Flat Washer
9	153005	2	3/8" Lock Washer
10	152005	2	3/8-16 Hex Nut
11	150501	4	5/16-18 x 3/4" Hex Head Machine Bolt
12	153002	4	5/16" Lock Washer
13	153001	4	5/16" Flat Washer
14	150621	2	5/16-18 x 1-1/2" Hex Head Machine Bolt
15	152004	2	5/16-18 Hex Nut
16	801101	1	1-3/8" Bearing Box Assembly Complete (for models mfd. without rotational sensor) (includes illus. nos. 4 through 20)
	801103	1	1-3/8" Bearing Box and Support ONLY (includes illus. nos. 4 through 6, 16, and 17)
	801105	1	1-3/8" Bearing Box ONLY
17	801104	1	Pillow Block Bearing Support ONLY
18	880779	1	1-3/8" Pillow Block Bearing Assembly with Magnet (for models mfd. with rotational sensor)
	880202	1	1-3/8" Pillow Block Bearing with Nylock Setscrews
19	152004	2	5/16-18 Hex Nut
20	150610	2	5/16-18 x 1-1/2" Allen Setscrew
21	101100	1	18" Pulley (for non-reversing models Only)
	101118	1	18-3/4" Pulley (for reversing models Only)
	101110	1	1" Taper Lock Hub (key is not included) (for reversing models Only)
	100735	1	Shaft Key (for taper lock hub)
22	154301	2	5/16-18 x 1" Allen Setscrew
23	100713	1	1/4" x 1/4" x 7/8" Key
24	100100	1	5L-660 V-Belt (tumbler to idler) (for non-reversing models Only)
	100108	1	5L-680 V-Belt (tumbler to idler) (for reversing models Only)
25	824807	1	Rotational Sensor Assembly

\* As required.

# Tumbler / Support Assemblies

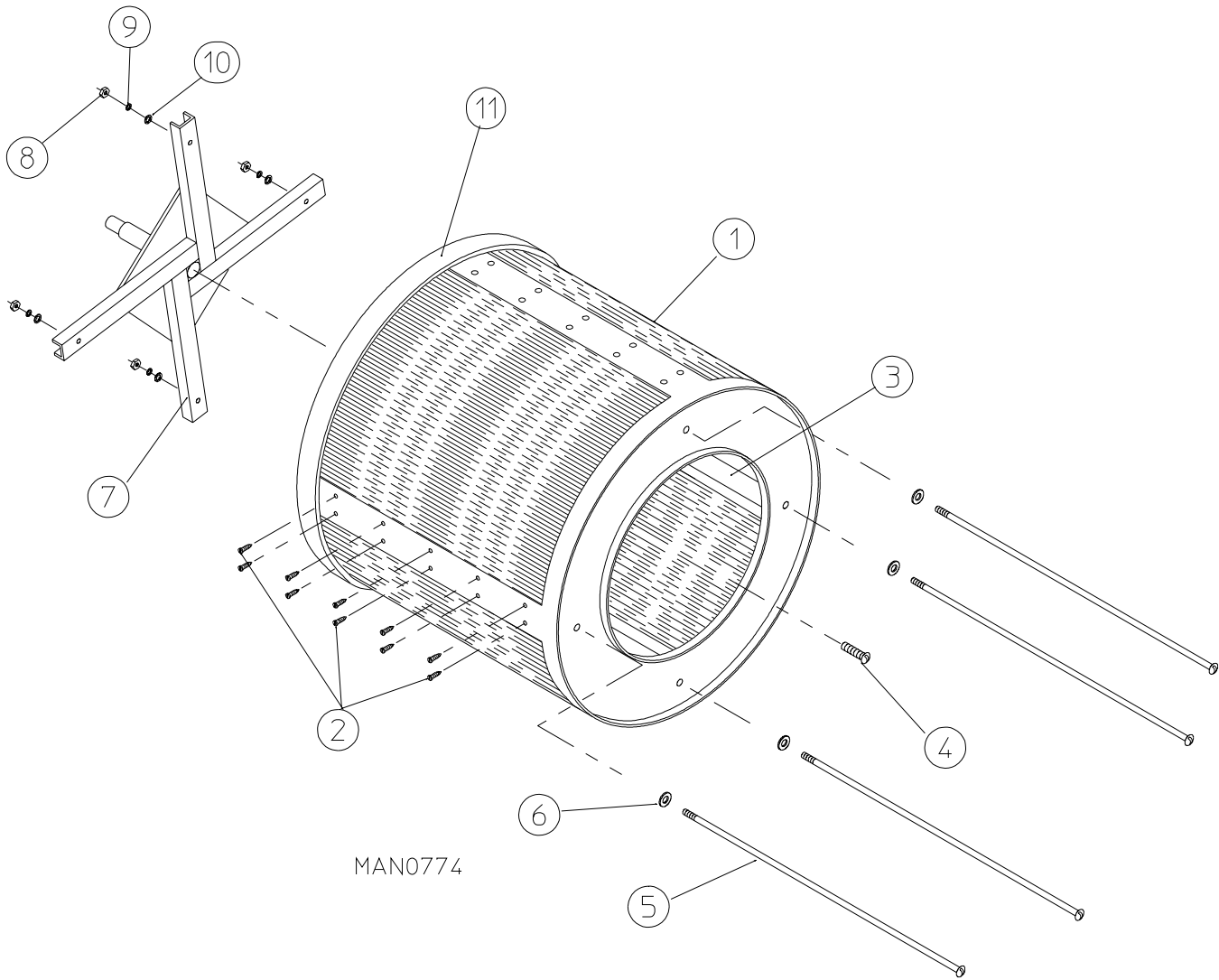

<u>Illus. No.</u>	<u>Part No.</u>	<u>Qty.</u>	<u>Description</u>
1*	800838	1	Galvanized Tumbler ONLY (without felt collar)
	800736	1	Stainless Steel Tumbler ONLY (without felt collar)
	800837	1	Galvanized Tumbler and Support Assembly with Tapered Ribs (includes illus. nos. 1 through 10)
	882683	1	Stainless Steel Tumbler and Support Assembly with Tapered Ribs (includes illus. nos. 1 through 10)
2	150413	40	#10-16 x 1/2" TORX® Crimptite Screw
	150429	1	TORX® Screw Hand Driver
3	301302	2	Tumbler Rib ONLY (low rib)
	301311	2	Tapered Tumbler Baffle Rib ONLY (high rib)
4	150500	1	5/16-18 x 3/4" Socket Button Head Screw
5	100903	4	3/8-16 x 38-1/2" Tie Rod
6	153004	4	3/8" Flat Washer
7	800616	1	Tumbler Support
8	152005	4	3/8-16 Hex Nut
9	153005	4	3/8" Lock Washer
10	153004	4	3/8" Flat Washer
11	116001	1	Felt Collar
—	401010	1	#847 Adhesive for Felt Collar (5.0 oz. tube)

\* Felt collar is not included and must be ordered separately.

# Non-Reversing T.E.F.C. Motor Mount Assembly

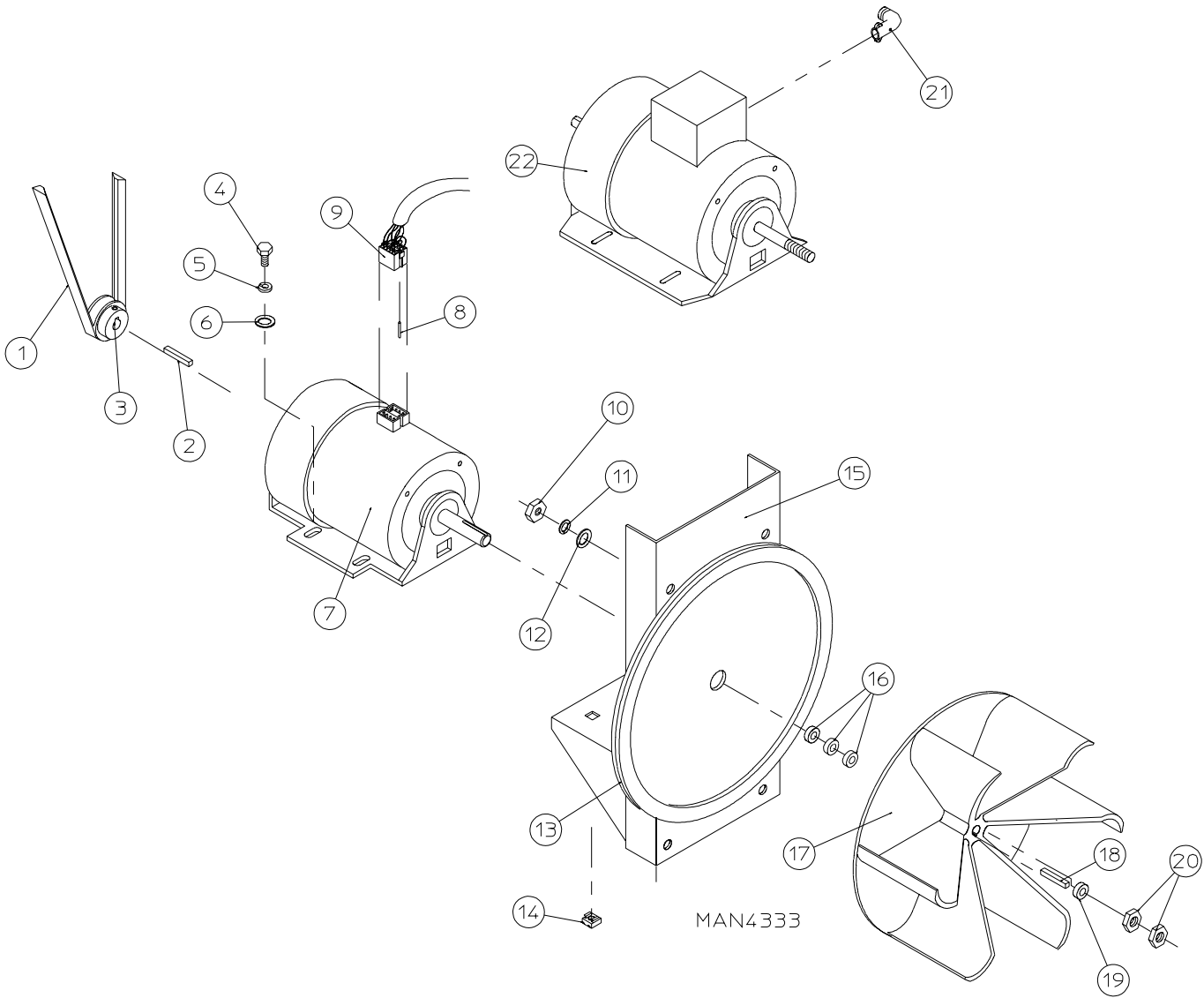

## Non-Reversing T.E.F.C. Motor Mount Assembly

<u>Illus. No.</u>	<u>Part No.</u>	<u>Qty.</u>	<u>Description</u>
1	100105	1	4L-520 V-Belt (motor to idler)
2	100701	1	3/16" x 3/16" x 1" Key (for use on 3ø models Only)
3	101132	1	5/8" x 2" Motor Pulley (for use on 60 Hz models Only)
	101133	1	5/8" x 2-1/4" Motor Pulley (for use on 50 Hz models Only)
4	150501	4	5/16-18 x 3/4" Hex Head Machine Bolt
5	153002	4	5/16" Lock Washer
6	153001	4	5/16" Flat Washer
7	100069*	1	3/4 hp 120-230v 1ø Totally Enclosed, Fan-Cooled Motor with Plug (56Z frame) for 60 Hz Models ONLY
	100068	1	3/4 hp 240v 1ø Totally Enclosed, Fan-Cooled Motor with Plug (56Z frame) for 50 Hz Models ONLY
8	122701	8	Socket Terminal
	122801	1	Pin / Socket Extraction Tool
9	137030	1	8-Pin Housing Connector
10	152004	4	5/16-18 Hex Nut
11	153002	4	5/16" Lock Washer
12	153001	4	5/16" Flat Washer
13	117604	4	Neoprene Sponge Tape (sold by the foot)
14	154000	4	5/16-18 Tinnerman Nut
15	850017	1	Non-Reversing Motor Mount ONLY with Gasket (56Z frame) (includes illus. no. 13)
	817029*	1	3/4 hp 120/230v 1ø 60 Hz Totally Enclosed, Fan-Cooled Motor Mount Assembly Complete with Plug Motor (includes illus. nos. 3 through 7 and 13 through 20)
	817074*	1	3/4 hp 240v 1ø 50 Hz Totally Enclosed, Fan-Cooled Motor Mount Assembly Complete with Plug Motor (includes illus. nos. 3 through 7 and 13 through 20)
	817080*	1	1/2 hp 208/230/380/460v 3ø 60 Hz Non-Reversing Totally Enclosed, Fan-Cooled Motor Mount Assembly Complete (includes illus. nos. 2 through 6 and 13 through 22)
	883271*	1	1/2 hp 208/230/380/460v 3ø 50 Hz Non-Reversing Totally Enclosed, Fan-Cooled Motor Mount Assembly Complete (includes illus. nos. 2 through 6 and 13 through 22)
16	153050	3	1/2" S.A.E. Flat Washer
17	100604	1	12-1/2" Impellor (fan / blower) with 1/2" Bore
18	100702	1	1/8" x 1/8" x 1-1/2" Key
19	153050	1	1/2" S.A.E. Flat Washer
20	152006	2	1/2-20 Left Hand Jam Nut
21	120200	1	3/8" x 90° Connector
22	100007*	1	1/2 hp 208/230/380/460v 3ø 50/60 Hz Totally Enclosed, Fan-Cooled Motor (56Z frame)

\* Specify voltage when ordering.

# Reversing T.E.F.C. Motor Mount Assembly

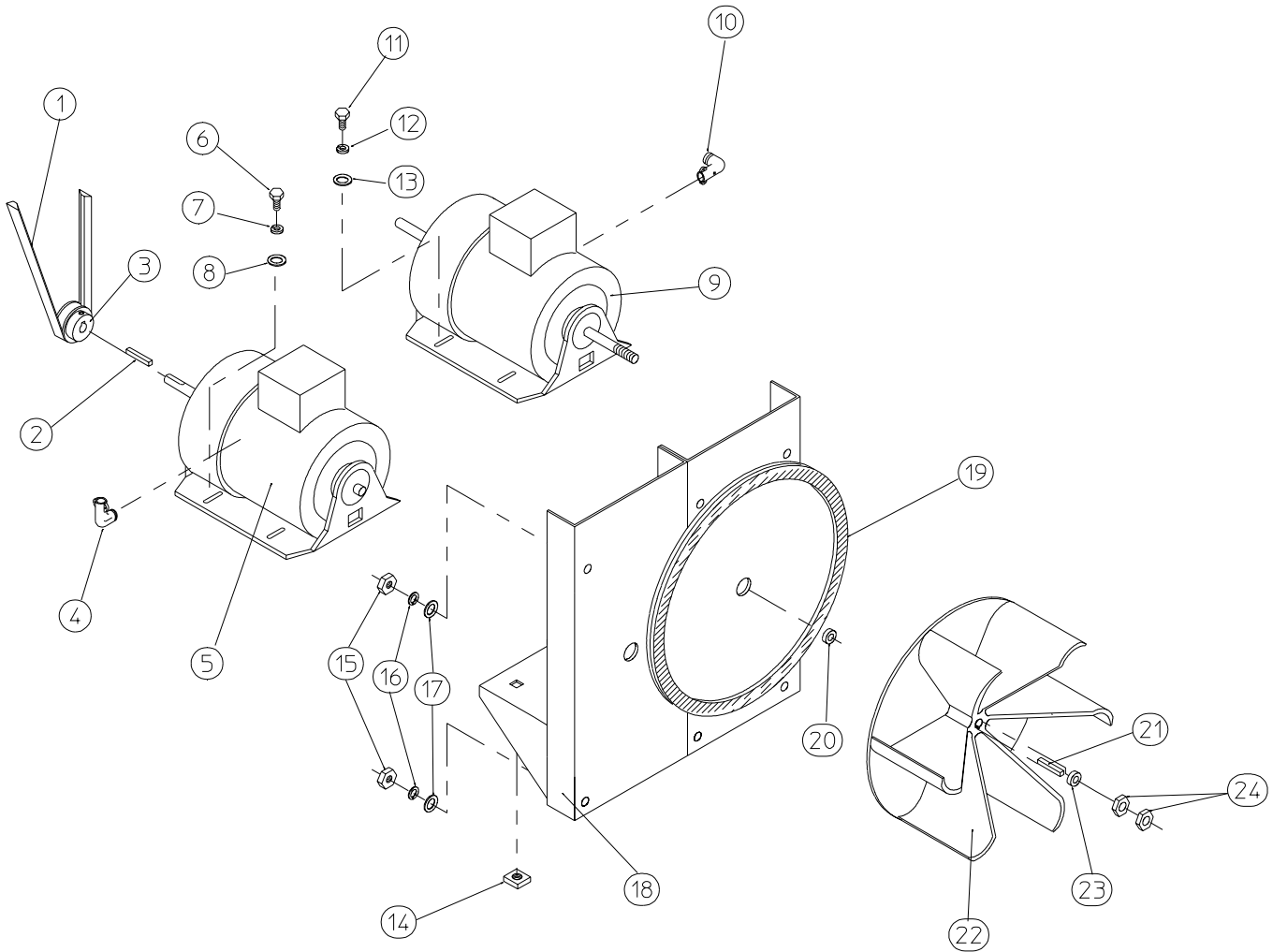

MAN0250



## Reversing T.E.F.C. Motor Mount Assembly

<u>Illus. No.</u>	<u>Part No.</u>	<u>Qty.</u>	<u>Description</u>
1	100112	1	4L-610 V-Belt (motor to idler)
2	100701	1	3/16" x 3/16" x 1" Key
3	101132	1	5/8" x 2" Motor Pulley (for 60 Hz models Only)
	101133	1	5/8" x 2-1/4" Motor Pulley (for 50 Hz models Only)
4	120200	1	3/8" x 90° Connector
5*	181003	1	1/2 hp 208/230/380/460v 3ø 50/60 Hz Totally Enclosed, Fan-Cooled (56Z frame)
6	150501	4	5/16-18 x 3/4" Hex Head Machine Bolt
7	153002	4	5/16" Lock Washer
8	153001	4	5/16" Flat Washer
9*	100007	1	1/2 hp 208/230/380/460v 3ø 50/60 Hz Totally Enclosed, Fan-Cooled Motor (56Z frame)
10	120200	1	3/8" x 90° Connector
11	150501	4	5/16-18 x 3/4" Hex Head Machine Bolt
12	153002	4	5/16" Lock Washer
13	153001	4	5/16" Flat Washer
14	154000	8	5/16" Tinnerman Nut
15	152004	7	5/16" Hex Nut
16	153002	4	5/16" Lock Washer
17	153001	4	5/16" Flat Washer
18	850070	1	Reversing Motor Mount ONLY with Gasket (56Z frame) (includes illus. no. 19)
	803802*	1	Reversing Totally Enclosed, Fan-Cooled Motor Mount Assembly Complete For 60 Hz Models ONLY (includes illus. nos. 2 through 14 and 18 through 24)
	803803*	1	Reversing Totally Enclosed, Fan-Cooled Motor Mount Assembly Complete For 50 Hz Models ONLY (includes illus. nos. 2 through 14 and 18 through 24)
19	117604	4	Neoprene Sponge Tape (sold by the foot)
20	153050	1	1/2" S.A.E. Flat Washer
21	100702	1	1/8" x 1/8" x 1-1/2" Key
22	100604	1	12-1/2" Impellor with 1/2" Bore
23	153050	2	1/2" S.A.E. Flat Washer
24	152006	2	1/2-20 Left Hand Jam Nut

\* Specify voltage when ordering.

# Sensor Bracket Assemblies

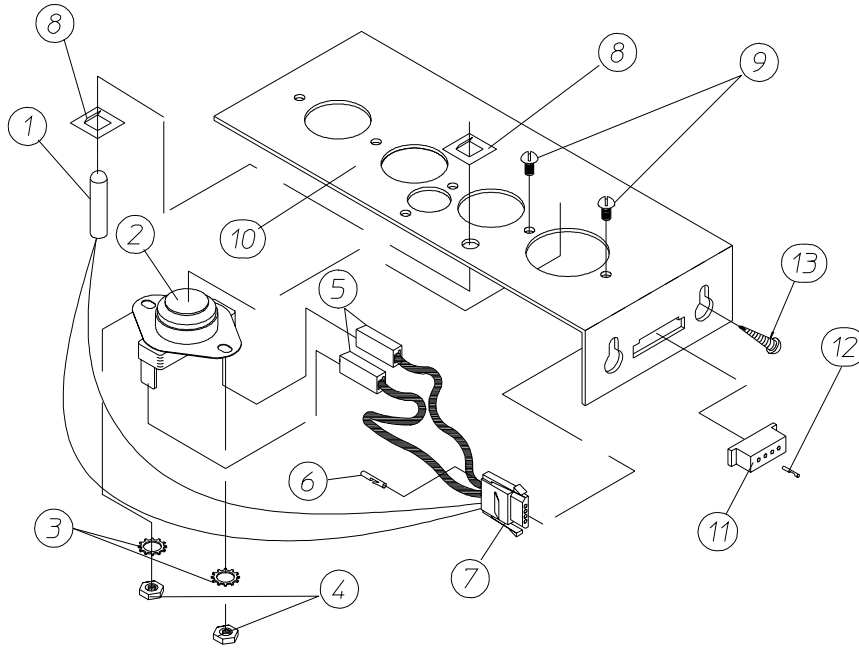

MICROPROCESSOR SENSOR BRACKET ASSEMBLY

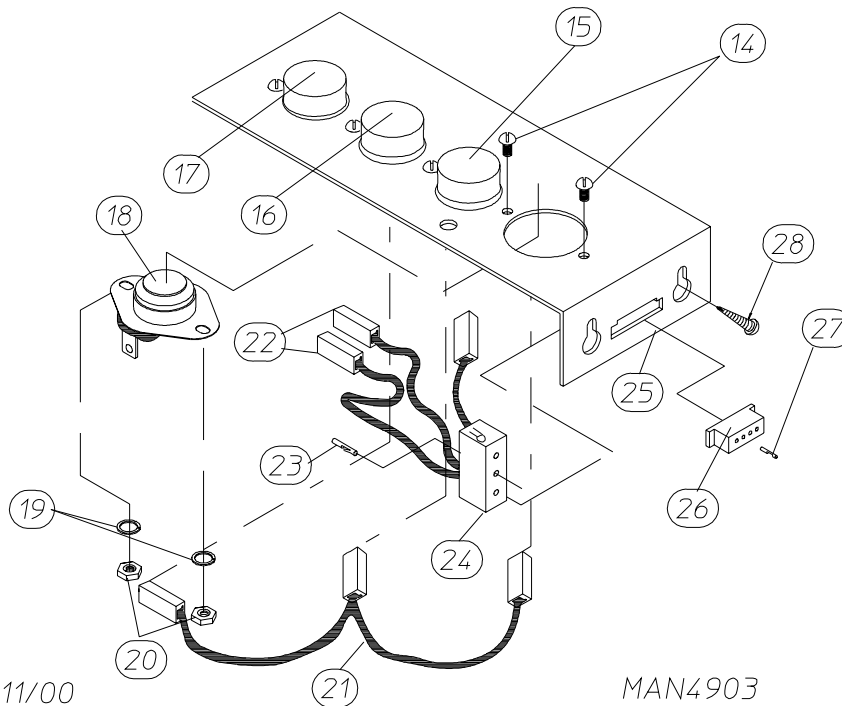

DX 01/11/00

MAN4903

NON-COMPUTER SENSOR BRACKET ASSEMBLY

<u>Illus. No.</u>	<u>Part No.</u>	<u>Qty.</u>	<u>Description</u>
1	880251	1	1/4" Temperature Sensor Probe Assembly (includes illus. nos. 1 and 5 through 8)
2	130301	1	225° Manual Reset Thermostat
3	153010	2	#6 Star Washer
4	152000	2	#6-32 Hex Nut
5	121028	2	Insulated Terminal
6	122701	4	Socket Terminal
7	122605	1	4-Pin Socket Connector
8	154007	2	1/4" Tinnerman Push-On Fastener
9	150005	2	#6-32 x 1/4" Round Head Machine Screw
10	817046	1	Microprocessor Sensor Bracket Assembly Complete (includes illus. nos. 1 through 10)
	322062	1	Universal Sensor Bracket ONLY
11	122604	1	4-Pin Connector
12	122700	4	Pin Terminal
13	150301	2	#8-18 x 7/16" Phillips Pan Head TEK Screw
14	150005	5	#6-32 x 1/4" Phillips Round Head Machine Screw
15	130111	1	130° Thermostat
16	130100	1	150° Thermostat
17	130301	1	225° Manual Reset Thermostat
18	130101	1	180° Thermostat
19	153010	5	#6 Star Washer
20	152000	5	#6-32 Hex Nut
21	882535	1	Sensor Jumper
22	121028	4	Insulated Terminal
23	122701	4	Socket Terminal
24	122605	1	4-Pin Socket Connector
	882534	1	Sensor Bracket Harness Assembly (includes illus. nos. 22 through 24)
25	882536	1	Noncomputer Sensor Bracket Assembly Complete (includes illus. nos. 14 through 25)
	322062	1	Universal Sensor Bracket ONLY
26	122604	1	4-Pin Connector
27	122700	4	Pin Terminal
	122801	1	Pin / Socket Extraction Tool
28	150301	2	#8-18 x 7/16" Phillips Pan Head TEK Screw

# Direct Spark Ignition Burner Assembly

For Models Mfd. as of April 7, 2000

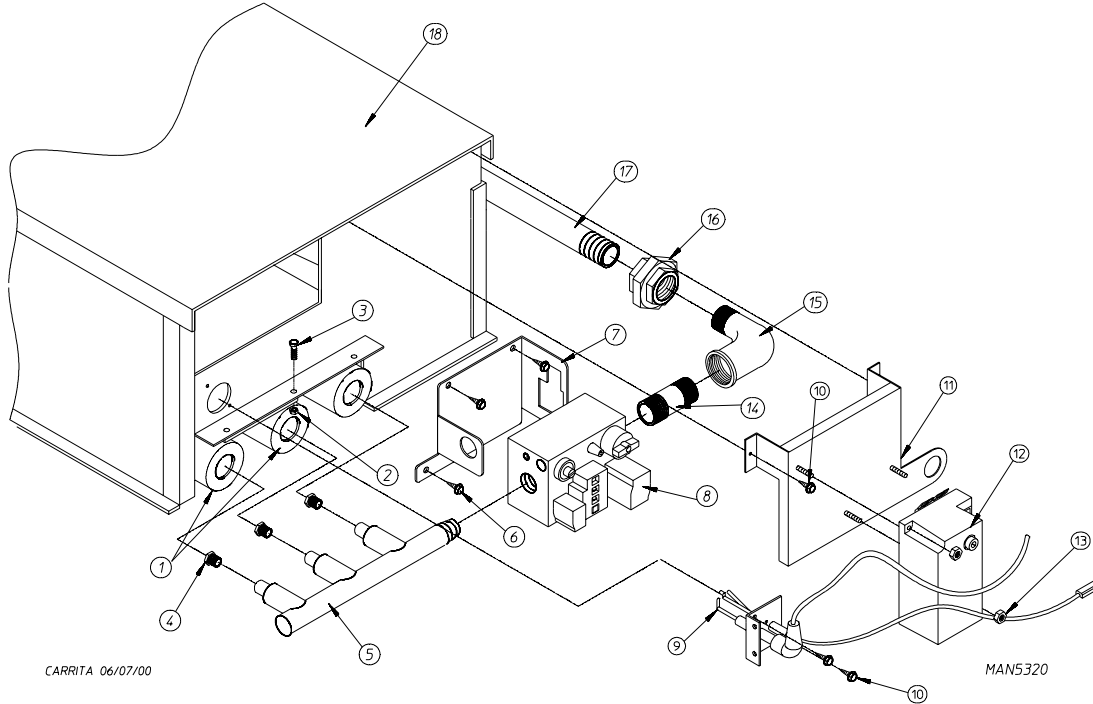

Illus. No.	Part No.	Qty.	Description
1	141105	3	Large Tube Burner
2	151001	3	#8-32 Pal Nut
3	150108	3	#8-32 x 1/2" Pan Head Machine Screw
4*	140820	3	#29 Natural Gas Burner Orifice
	140806	3	#46 Liquid Propane Burner Orifice
5	141232	1	1/2" Direct Spark Ignition Manifold (3-port)
6	150309	3	#10-16 x 1/2" Hex Head TEK Crimptite Screw
7	318714	1	Gas Valve Bracket (horizontal)
8	128927	1	1/2" 24 VAC Redundant (natural gas) Gas Valve
	880960		1/2" 24 VAC Redundant (liquid propane gas) Gas Valve
9	884265	1	Ignitor Probe Assembly
	884278	1	High Voltage Wire (for models with 1/4" spade connection at module)
	128919	1	High Voltage Wire (for models with spike style connection at module)
	882537	1	Flame-Probe Wire
10	150300	2	#10-16 x 1/2" Hex Washer TEK Screw
11	817027	1	Direct Spark Ignition Module Mounting Bracket Assembly
12	883849	1	Direct Spark Ignition Module with 3 Tries
13	152013	2	#6-32 Hex Nut
14	142707	1	1/2" x 1-1/2" Black Nipple
15	142506	1	1/2" Street Elbow
16	142600	1	1/2" Black Union
17	142809	1	1/2" x 29" Pipe / Nipple
18	817062	1	Direct Spark Ignition Burner Assembly Complete (natural gas) (includes illus. nos. 1 through 3 and 5 through 18)
	817063	1	Direct Spark Ignition Burner Assembly Complete (liquid propane gas) (includes illus. nos. 1 through 3 and 5 through 18)
—	850899	1	Direct Spark Ignition Burner Box ONLY
—	882271*	1	ADG-50V Liquid Propane Conversion Kit (includes orifices)
—	883310**	1	Steam to Gas Transition Plate ... Not Illustrated

\* Consult factory for elevations over 2,000 feet.

\*\* Needed when converting dryer from steam heat to gas heat.

# Direct Spark Ignition Burner Assembly

For Models Mfd. prior to April 7, 2000

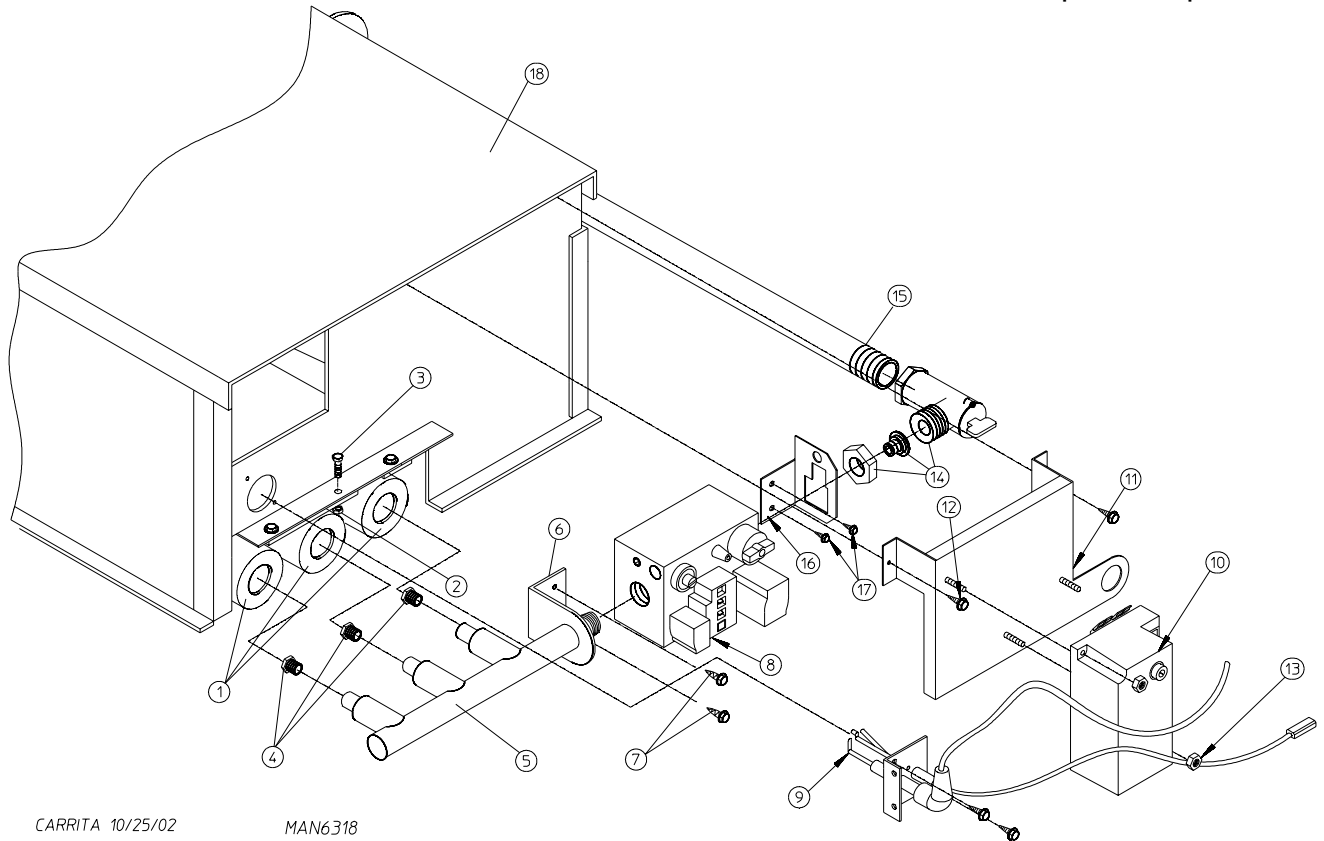

CARRITA 10/25/02

MAN6318

<u>Illus. No.</u>	<u>Part No.</u>	<u>Qty.</u>	<u>Description</u>
1	141105	3	Large Tube Burner
2	151001	3	#8-32 Pal Nut
3	150108	3	#8-32 x 1/2" Pan Head Machine Screw
4*	140820	3	#29 Natural Gas Burner Orifice
	140806	3	#46 Liquid Propane Burner Orifice
5	141232	1	1/2" Direct Spark Ignition Manifold (3-port)
6	318700	2	Pipe Bracket (bent)
7	150300	2	#10-16 x 1/2" Hex Washer TEK Screw
8	128927	1	1/2" 24 VAC Redundant (natural gas) Gas Valve
	880960	1	1/2" 24 VAC Redundant (liquid propane gas) Gas Valve
9	884265	1	Ignitor Probe Assembly
	884278	1	High Voltage Wire (for models with 1/4" spade connection at module)
	128919	1	High Voltage Wire (for models with spike style connection at module)
	882537	1	Flame-Probe Wire
10	883849	1	Direct Spark Ignition Module with 3 Tries
11	817027	1	Direct Spark Ignition Module Mounting Bracket Assembly
12	150309	3	#10-16 x 1/2" Hex Head TEK Crimptite Screw
13	152013	2	#6-32 Hex Nut
14	141313	1	90° x 1/2" x 1" Gas Shutoff Assembly
15	142809	1	1/2" x 29" Pipe / Nipple
16	318712	1	Gas Valve Pipe Bracket
17	150309	4	#10-16 x 1/2" Hex Head TEK Crimptite Screw
18	850899	1	Direct Spark Ignition Burner Box ONLY
—	882271*	1	ADG-50V Liquid Propane Conversion Kit (includes orifices)
—	883310**	1	Steam to Gas Transition Plate ... Not Illustrated

\* Consult factory for elevations over 2,000 feet.

\*\* Needed when converting dryer from steam heat to gas heat.

# Electric Oven Assembly

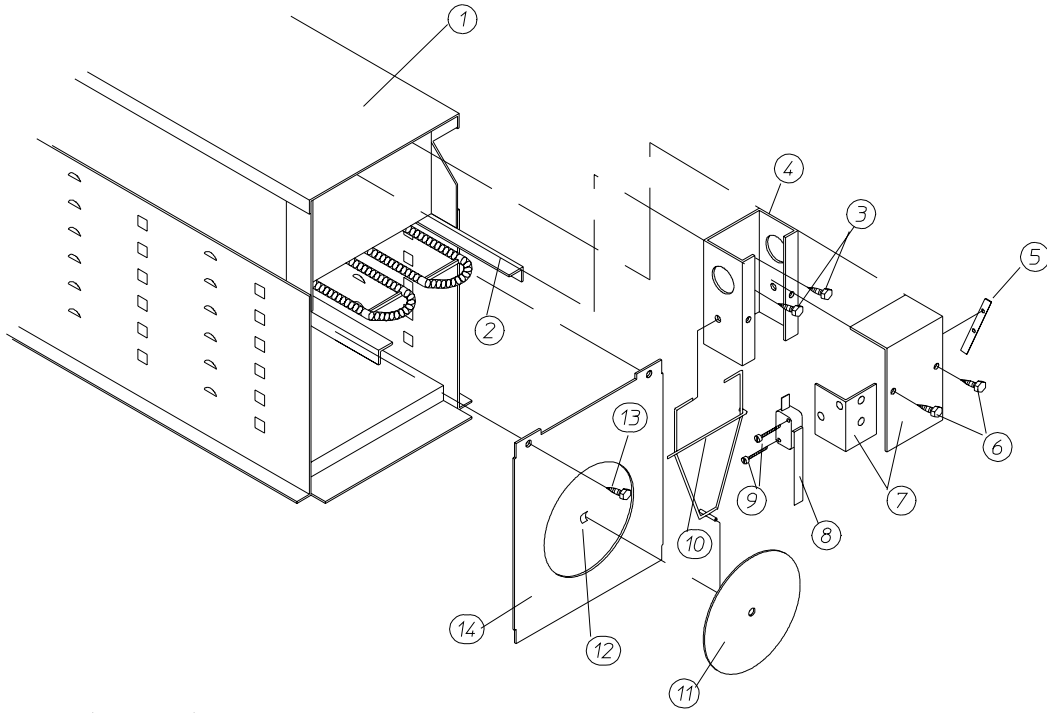

ELECTRIC OVEN (FRONT VIEW)

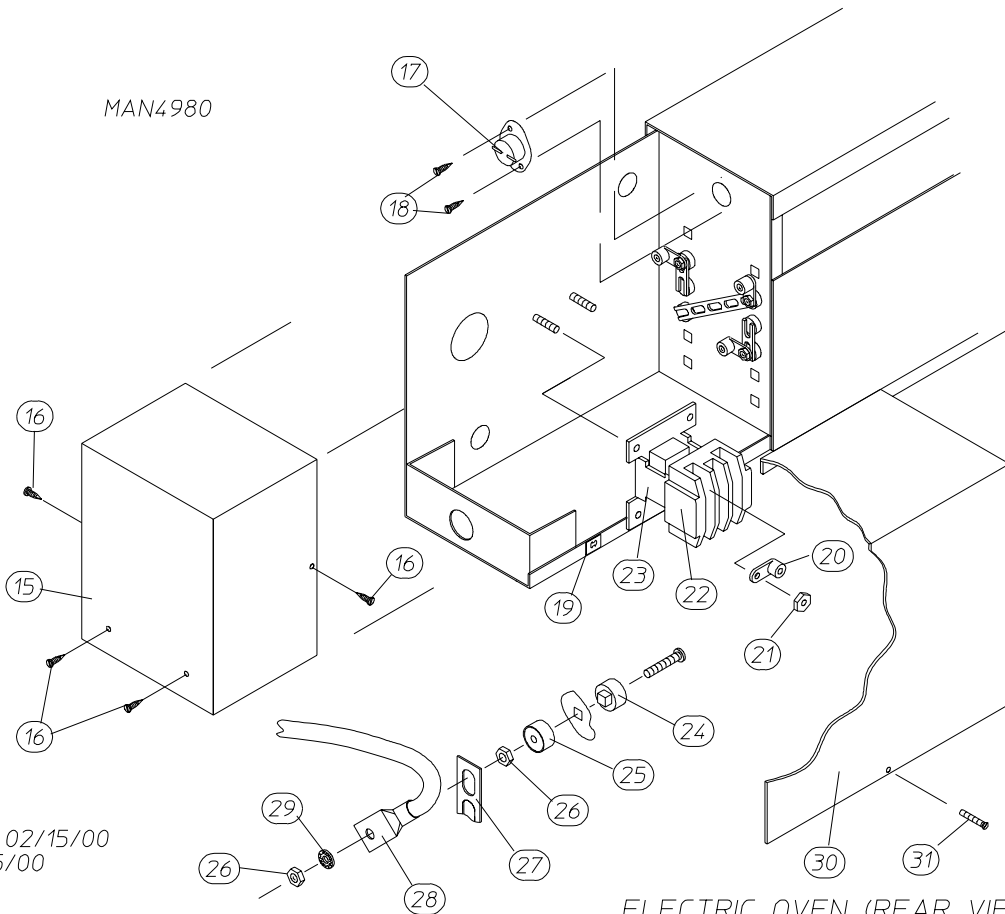

MAN4980

TCOSTA 02/15/00  
DX 01/25/00

ELECTRIC OVEN (REAR VIEW)

<u>Illus. No.</u>	<u>Part No.</u>	<u>Qty.</u>	<u>Description</u>
1	803007*	1	Large Electric Oven Box
	-----*	1	Electric Oven Assembly Complete
2	-----*	-	Electric Element
3	150300	2	#10-16 x 1/2" Hex Washer TEK Screw
4	802800	1	Sail Switch Box with Bracket and Cover ONLY
	802801	1	Sail Switch Box Assembly Complete (includes illus. nos. 4 through 12)
5	154004	1	Twin Speed Nut
6	150300	2	#10-16 x 1/2" Hex Washer TEK Screw
7	802799	1	Sail Switch Box Cover and Bracket
8	122200	1	Sail Switch
9	150303	2	#4 x 3/4" Pan Head "A" Machine Screw
10	105500	1	Sail Switch Actuator Rod
11	319202	1	Sail Switch Damper (flat)
12	154002	1	1/8" Push-On Fastener
13	150300	2	#10-16 x 1/2" Hex Washer TEK Screw
14	803100	1	Electric Oven Front Cover
15	320611	1	Large Relay Box Cover
16	150301	2	#8-18 x 7/16" Phillips Pan Head TEK Screw
17	130400	1	290° Hi-Limit Thermostat
18	150300	2	#10-16 x 1/2" Hex Washer TEK Screw
19	154001	2	#10-24 Speed Nut
20	121010	1	L-70 Ground Lug
21	152014	3	1/4-20 Free Spin Wash Nut
22	-----*	1	Oven Relay
23	-----*	1	Oven Relay Replacement Coil
24	120081	-	Internal Ceramic Insulator (2 per element)
25	120080	-	External Ceramic Insulator (2 per element)
26	152008	-	#10-32 Hex Nut (4 per element)
27	121011	-	Bus Bar (sold by the foot)
28	-----*	-	Terminal Lug
29	153009	-	#10 Star Washer (2 per element)
30	321301	1	Large Electric Oven Right Side Cover
31	150207	2	#10-24 x 1/2" Phillips Pan Head Machine Screw
—	883310**	1	Steam to Electric Transition Plate ... Not Illustrated

\* Refer to Electric Oven Component Application Chart on page 52.

\*\* Needed when converting dryer from steam heat to electric heat.

# Gas Burner Sail Switch / Hi-Limit Assemblies

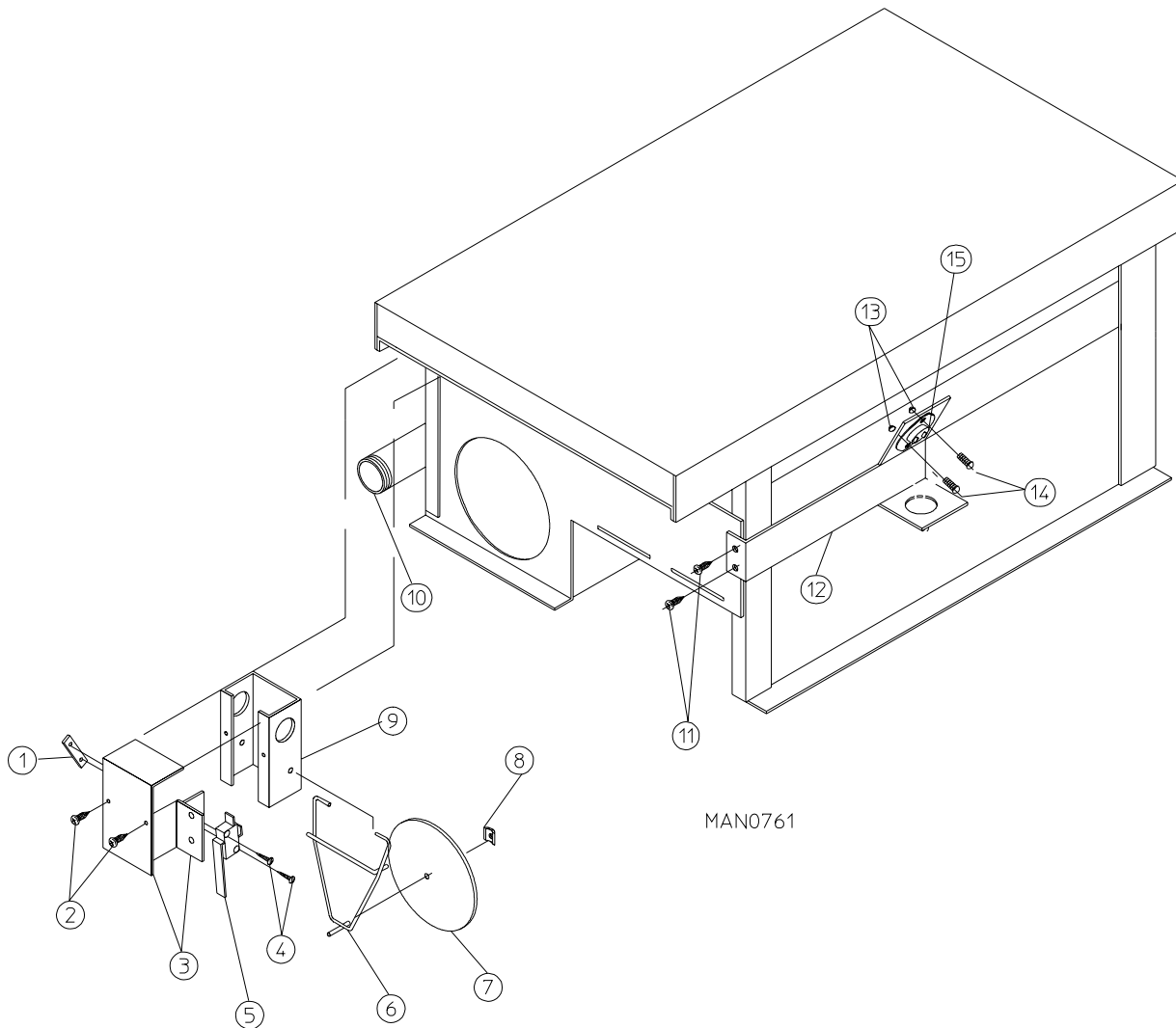

<u>Illus. No.</u>	<u>Part No.</u>	<u>Qty.</u>	<u>Description</u>
1	154004	1	Twin Speed Nut
2	150300	2	#10-16 x 1/2" Hex Washer TEK Screw
3	802799	1	Sail Switch Box Cover and Bracket
4	150303	2	#4 x 3/4" Pan Head "A" Machine Screw
5	122200	1	Sail Switch
6	105500	1	Sail Switch Actuator Rod
7	319202	1	Sail Switch Damper (flat)
8	154002	1	1/8" Push-On Fastener
9	802800	1	Sail Switch Box with Cover and Bracket ONLY
	802801	1	Sail Switch Assembly Complete (includes illus. nos. 1 through 9)
10	142809	1	1/2" x 29-1/8" Pipe / Nipple
11	150300	2	#10-16 x 1/2" Hex Washer TEK Screw
12	319704	1	Hi-Limit Mounting Bracket
13	151000	2	#6-32 Pal Nut
14	150001	2	#6-32 x 1/2" Phillips Round Head Machine Screw
15	130201	1	330° Manual Reset Hi-Limit Thermostat



# Single-Phase (1 $\phi$ ) Motor, Electric Relay Panel Assembly

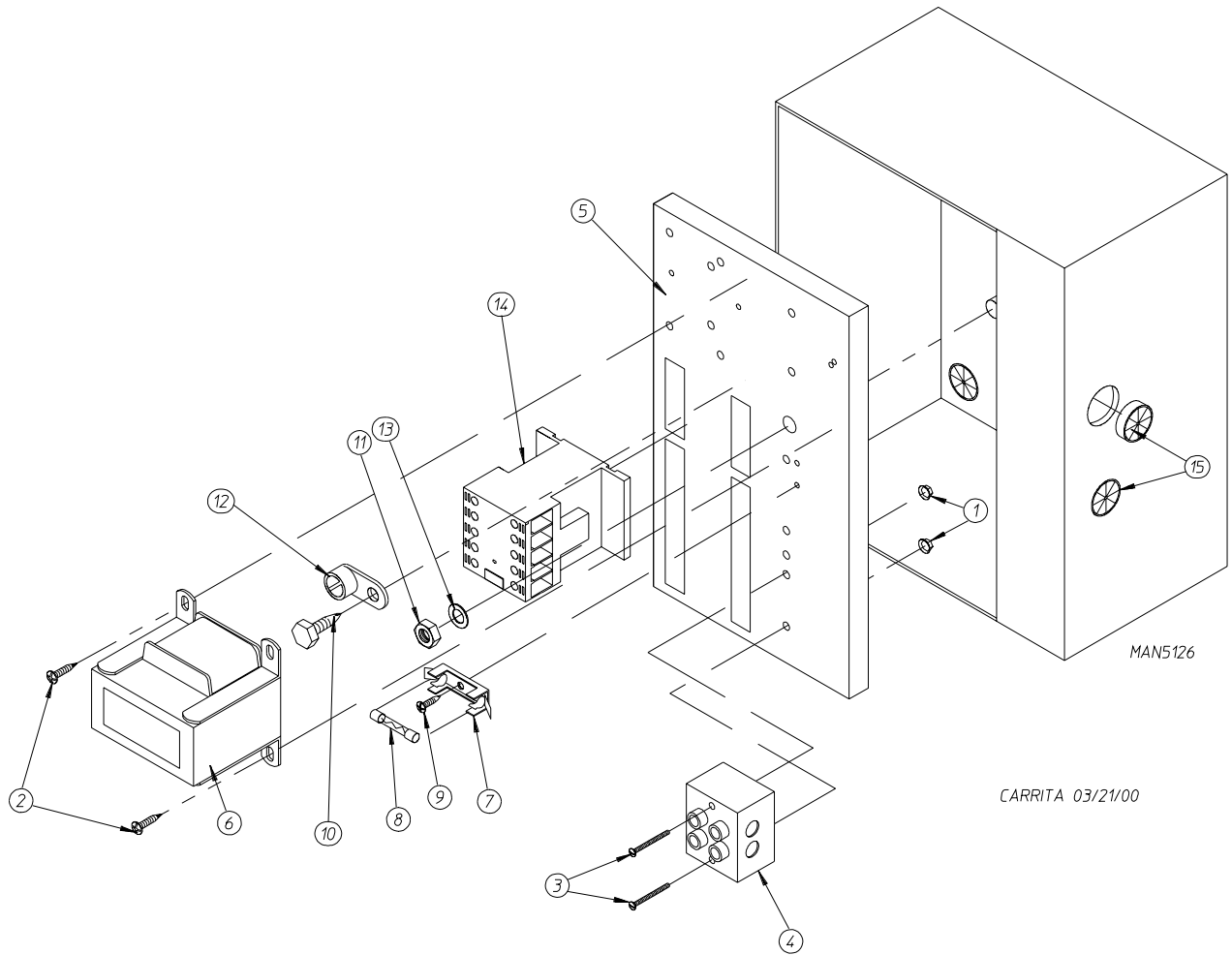

Illus. No.	Part No.	Qty.	Description
1	151000	2	#6-32 Pal Nut
2	150300	2	#10-16 x 1/2" Hex Washer TEK Screw
3	150008	2	#6-32 x 1-1/4" Phillips Pan Head Machine Screw
4	120716	1	2-Position Terminal Block
5	322817	1	Rear Electric Mounting Plate ONLY
	882662	1	Rear Electric Panel Assembly Complete – 120 Volt (includes illus. nos. 1 through 14)
	882663	1	Rear Electric Panel Assembly Complete – 208-240 Volt (includes illus. nos. 1 through 14)
6	882652	1	Transformer Assembly – 120 Volt
	882653	1	Transformer Assembly – 208-240 Volt
7	136008	1 or 2	Fuse Holder
8	136049	1	3/4-Amp (Slo-Blo) Fuse – 120 Volt
	136057	2	1/2-Amp (Slo-Blo) Fuse – 208-240 Volt
9	150301	1	#8-18 x 7/16" Phillips Pan Head TEK Screw
10	150297	1	#10 x 1/2" Hex Washer TEK Screw (green)
11	152004	1	5/16-18 Hex Nut
12	121010	1	L-70 Ground Lug
13	153002	1	5/16" Lock Washer
14	132459	1	3-Pole Contactor
15	121300	3	Open / Closed Bushing

# 3-Phase (3 $\phi$ ) Motor, Electric Relay Panel Assembly

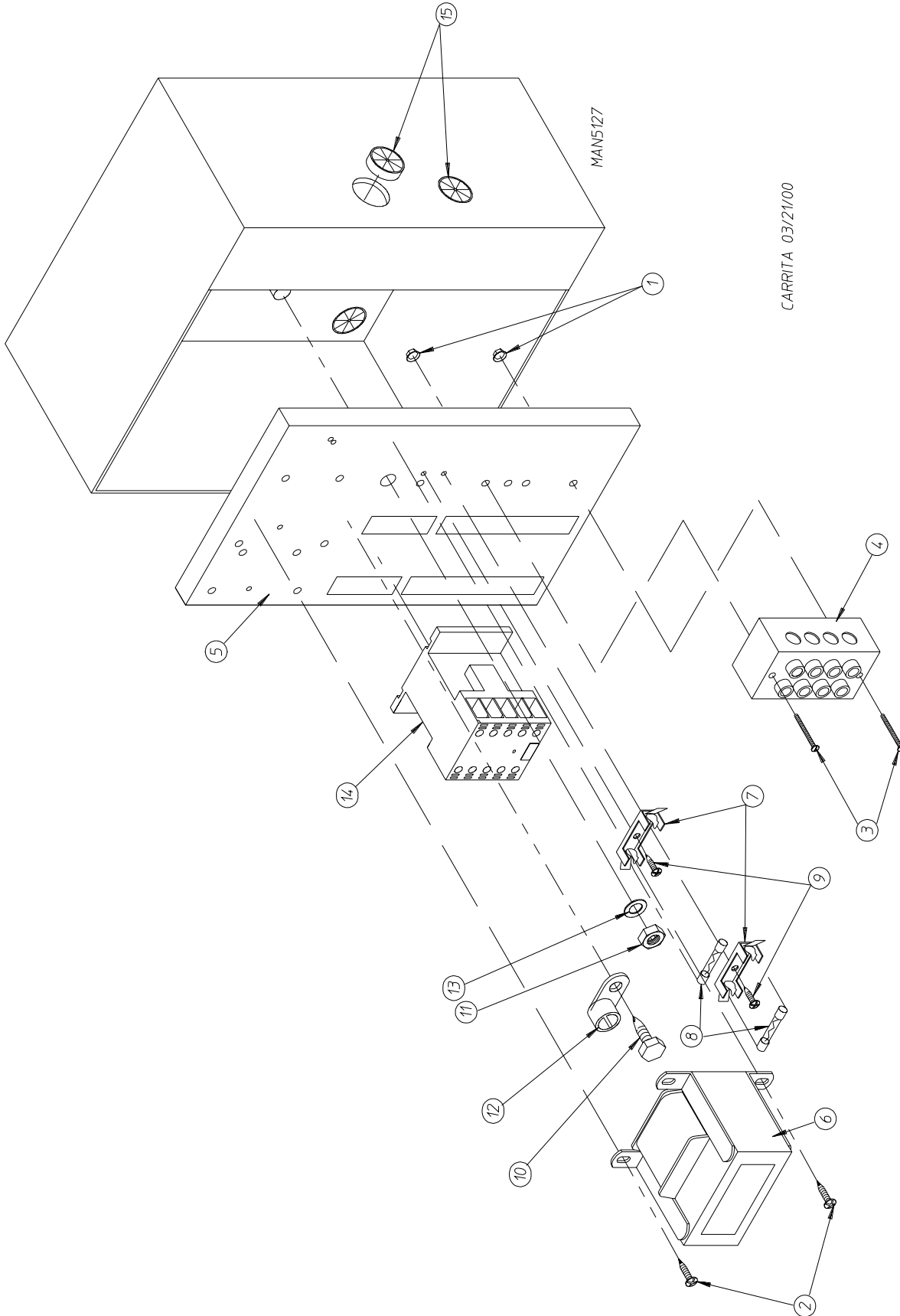

## 3-Phase (3Ø) Motor, Electric Relay Panel Assembly

---

<u>Illus. No.</u>	<u>Part No.</u>	<u>Qty.</u>	<u>Description</u>
1	151000	2	#6-32 Pal Nut
2	150300	2	#10-16 x 1/2" Hex Washer TEK Screw
3	150008	2	#6-32 x 1-1/4" Phillips Pan Head Machine Screw
4	120701	1	4-Position Terminal Block (for models mfd. with 3Ø motors)
	120716	1	2-Position Terminal Block (for models mfd. with 1Ø motors)
5	322817	1	Rear Electric Mounting Plate
	882664	1	Rear Electric Panel Assembly Complete – 208-240 Volt For Gas and Steam Models (includes illus. nos. 1 through 14)
	818400	1	Rear Electric Panel Assembly – 208-240 Volt For Electric Heated Models with 3Ø Motor (includes illus. nos. 1 through 14)
	818395	1	Rear Electric Panel Assembly Complete – 208-240 Volt For Electric Heated Models with Single-Phase (1Ø) Motor ONLY (includes illus. nos. 1 through 14)
	882665	1	Rear Electric Panel Assembly Complete for Gas and Steam Models – 380-416 Volt (includes illus. nos. 1 through 14)
	882667	1	Rear Electric Panel Assembly Complete – 380-416 Volt (includes illus. nos. 1 through 14) For Electric Heated Models with Single-Phase (1Ø) Motor ONLY
6	882653	1	Transformer Assembly – 208-240 Volt for Gas and Steam Models ONLY
	818396	1	Transformer Assembly – 208-240 Volt for Electric Heated Models ONLY
	882654	1	Transformer Assembly – 380-416 Volt
7	136008	2	Fuse Holder
8	136057	2	1/2-Amp (Slo-Blo) Fuse – 208-240 Volt
9	150301	2	#8-18 x 7/16" Phillips Pan Head TEK Screw
10	150297	1	#10 x 1/2" Hex Washer TEK Screw (green)
11	152004	1	5/16-18 Hex Nut
12	121010	1	L-70 Ground Lug
13	153002	1	5/16" Lock Washer
14	132459	1	3-Pole Contactor
15	121300	3	Open / Closed Bushing

# 460-480 VAC 3-Phase (3 $\phi$ ) Motor, Electric Relay Panel Assembly

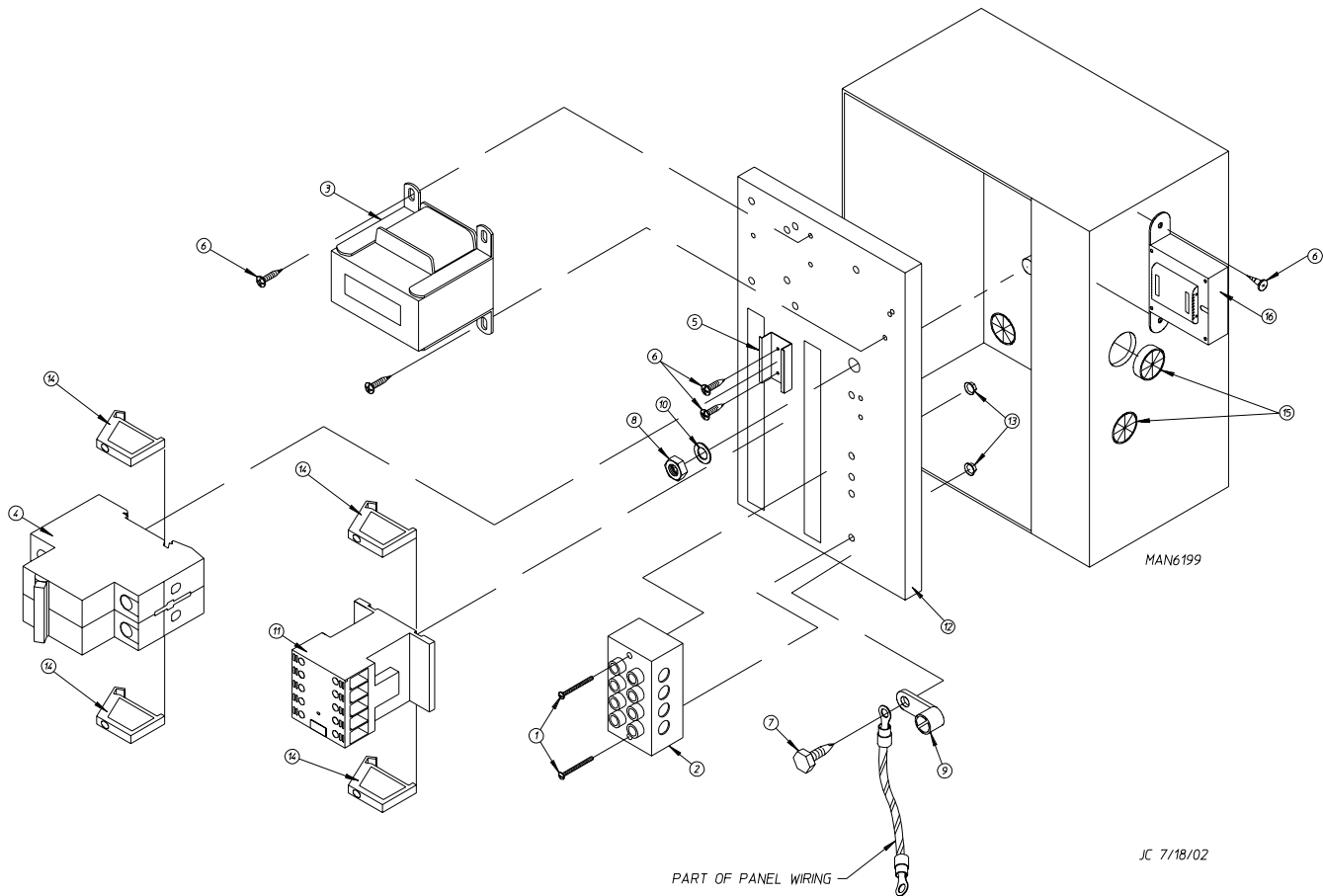

Illus. No.	Part No.	Qty.	Description
1	150009	2	#6-32 x 1-1/2" Phillips Pan Head Machine Screw
2	120701	1	4-Position Terminal Block
3	830208	1	Transformer Assembly (460 VAC) for Micro Models
	824161	1	Transformer Assembly (460 VAC) for Non-Micro Models
4	135501	1	1-Amp Double-Pole Circuit Breaker (460 VAC Only)
5	120768	2	35 x 15mm Din Rail
6	150301	4	#8-18 x 7/16" Phillips Pan Head TEK Screw
7	150297	2	#10 x 1/2" Ground Screw
8	152004	1	5/16-18 Hex Nut
9	121010	1	L-70 Ground Lug
10	153002	1	5/16" Lock Washer
11	132459	1	24 VAC 3-Pole Contactor
12	322817	1	Mounting Plate ONLY
	883332	1	Rear Panel Assembly Complete (460 VAC) for Micro Models (includes illus. nos. 1 through 14)
	830262	1	Rear Panel Assembly Complete (460 VAC) for Non-Micro Models (includes illus. nos. 1 through 14)
13	151000	2	#6-32 Pal Nut
14	120765	4	End Stop
15	121300	1	Open / Closed Bushing
16	141403	1	Control Voltage Transformer (24V) for Micro Models

# Reversing Electric Relay Panel Assembly

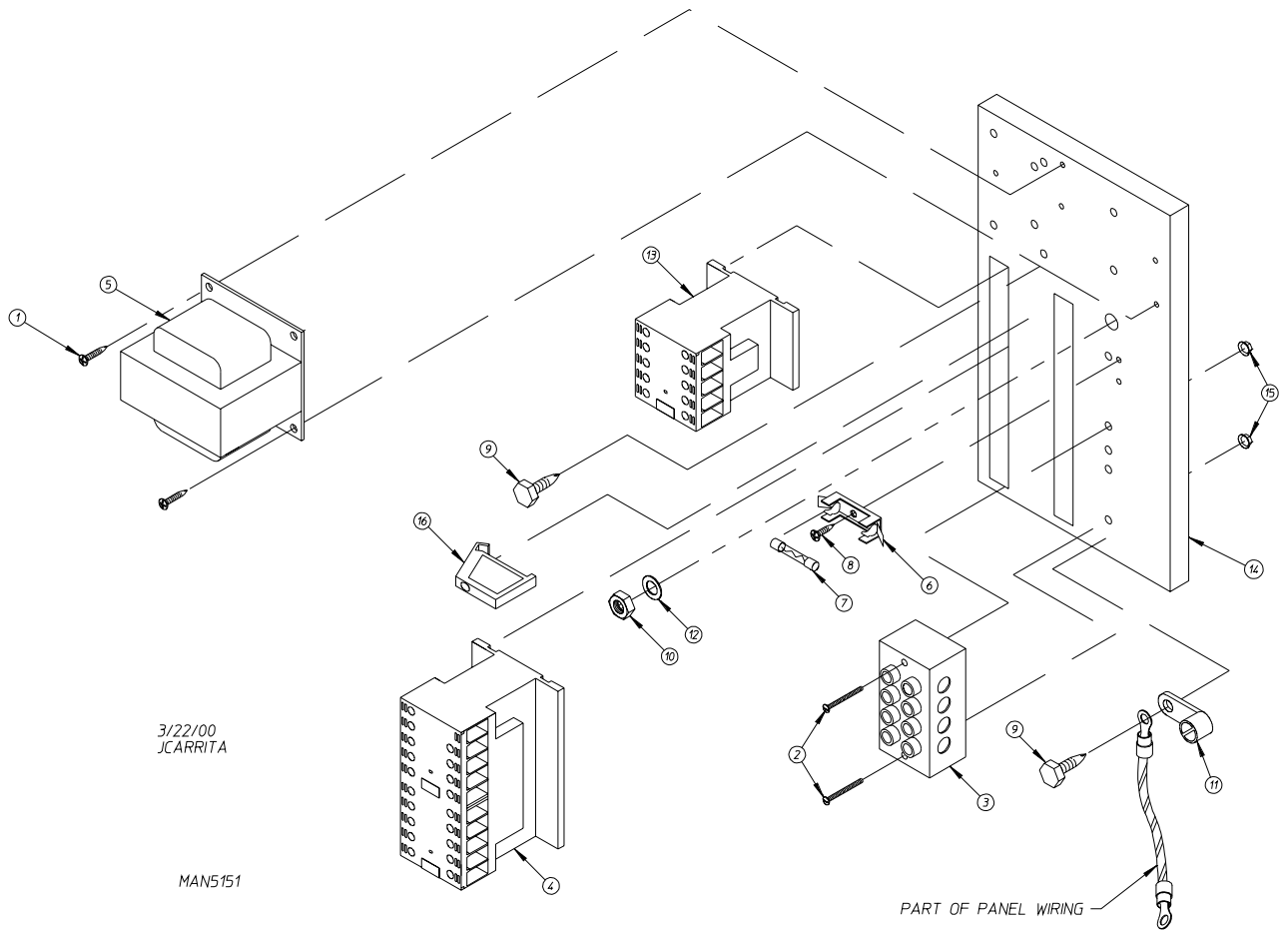

<u>Illus. No.</u>	<u>Part No.</u>	<u>Qty.</u>	<u>Description</u>
1	150300	2	#10-16 x 1/2" Hex Washer TEK Screw
2	150008	2	#6-32 x 1-1/4" Phillips Pan Head Machine Screw
3	120701	1	4-Position Terminal Block
4	132458	1	3-Pole Reversing Contactor
5	882653	1	Transformer Assembly (208-240 volt) for Gas and Steam Models
	825428	1	Transformer Assembly (208-240 volt) for Electric Heated Models
	882654	1	Transformer Assembly (380-416 volt)
6	136008	1	Fuse Holder
7	136057	1	1/2-Amp (Slo-Blo) Fuse ONLY (208-240 volt)
8	150301	1	#8-18 x 7/16" Phillips Pan Head TEK Screw
9	150297	1	#10 x 1/2" Hex Washer TEK Screw (green)
10	152004	1	5/16-18 Hex Nut
11	121010	1	L-70 Ground Lug
12	153002	1	5/16" Lock Washer
13	132459	1	3-Pole Contactor
14	322812	1	Rear Electric Mounting Plate ONLY
	882673	1	Rear Electric Panel Assembly Complete (208-240 volt) for Gas and Steam Models (includes illus. nos. 1 through 16)
	883335	1	Rear Electric Panel Assembly Complete (208-240 volt) for Electric Heated Models (includes illus. nos. 1 through 16)
	882676	1	Rear Electric Panel Assembly Complete (380-416 volt) (includes illus. nos. 1 through 16)
15	151000	2	#6-32 Pal Nut
16	120765	1	Standard End Bracket

# 460-480 VAC Reversing Electric Relay Panel Assembly

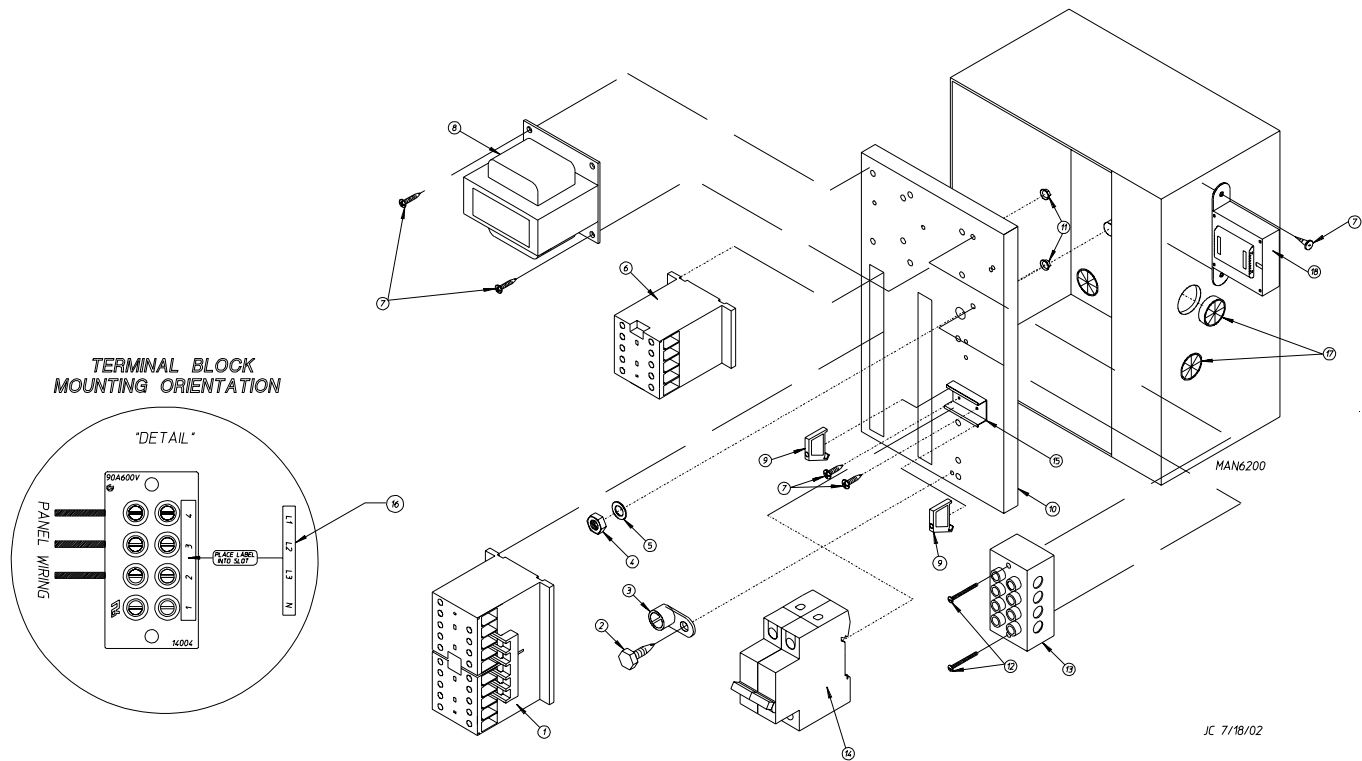

Illus. No.	Part No.	Qty.	Description
1	132458	1	24 VAC Reversing Contactor
2	150297	1	#10 x 1/2" Hex Head TEK Screw (green)
3	121010	1	L-70 Ground Lug
4	152004	1	5/16-18 Hex Nut
5	153002	1	5/16" Lock Washer
6	132459	1	24 VAC 3-Pole Blower Contactor
7	150300	4	#10-16 x 1/2" Hex Washer TEK Screw
8	830208	1	Transformer Assembly (460 VAC) for Micro Models
	824161	1	Transformer Assembly (460 VAC) for Non-Micro Models
9	120765	2	End Stop
10	322817	1	Mounting Plate ONLY
	883327	1	460 VAC Reversing Rear Electric Panel Assembly Complete for Micro Models (includes illus. nos. 1 through 16)
	-----*	1	460 VAC Reversing Rear Electric Panel Assembly Complete for Non-Micro Models (includes illus. nos. 1 through 16)
11	151000	2	#6-32 Pal Nut
12	150009	2	#6-32 x 1-1/2" Phillips Pan Head Machine Screw
13	120701	1	4-Position Terminal Block
14	135501	1	1-Amp Double-Pole Circuit Breaker
15	120768	2	35 x 15mm Din Rail (sold by the inch)
16	112068	1	3-Phase (3Ø) Power Input Label
17	121300	1	Open / Closed Bushing
18	141403	1	Control Voltage Transformer (24V) for Micro Models

\* Not available at time of printing. Contact factory for additional information.

# Steam Coil / Air-Operated Steam Damper Assembly

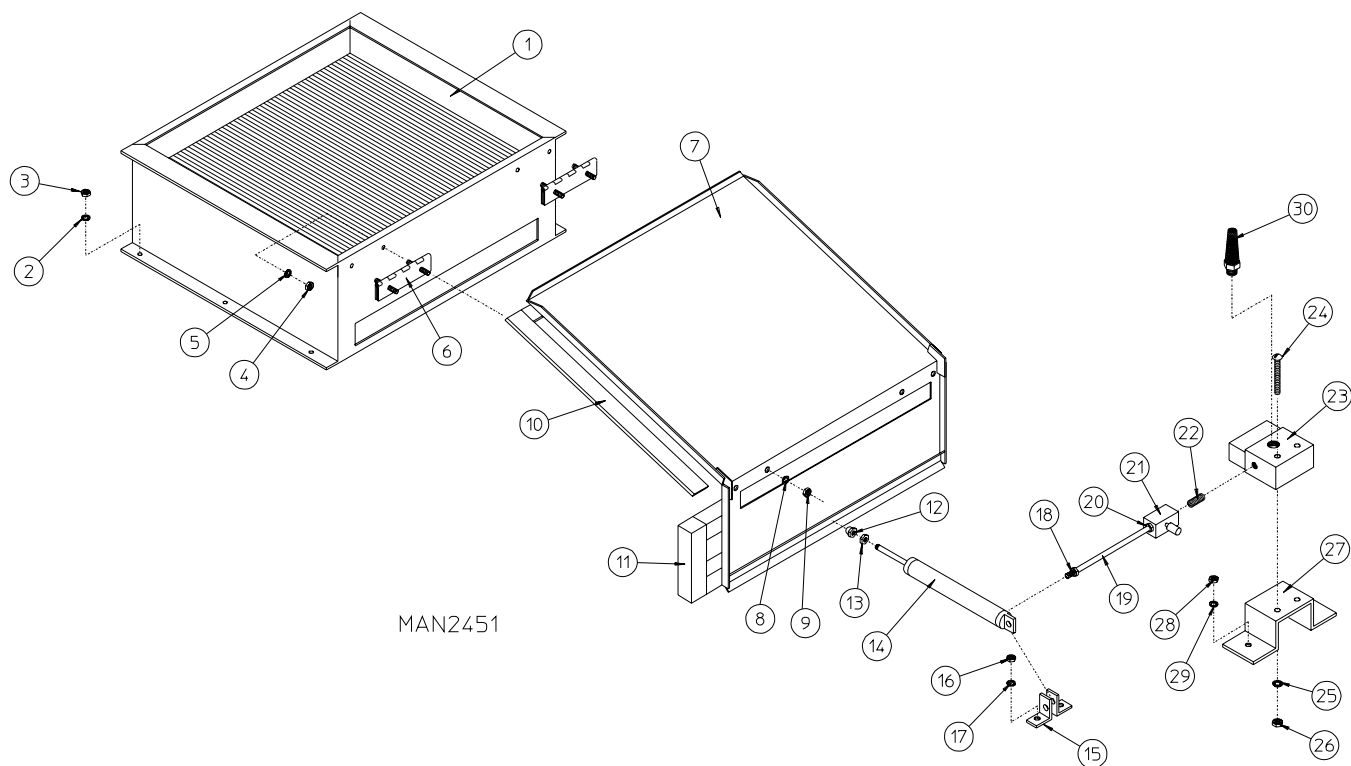

MAN2451

Illus. No.	Part No.	Qty.	Description
1	165011	1	Steam Coil Assembly
2	153002	6	5/16" Lock Washer
3	152004	6	5/16-18 Hex Nut
4	152002	4	1/4-20 Hex Nut
5	153007	4	1/4" Lock Washer
6	820321	2	Steam Damper Hinge Assembly
7	880280	1	Steam Damper Assembly (includes illus. nos. 7, 10, and 11)
9	152002	4	1/4-20 Hex Nut
10	115995	60	Steam Damper Gasket (sold by the inch)
11	102350	1	Steam Damper Foam (68-1/2" length)
12	151006	1	5/16-24 Stainless Steel Acorn Nut
13	152051	1	5/16-24 Right Hand Jam Nut
14	100495	1	11/16" x 3" Stroke Piston
15	323365	2	Left and Right Piston Support
16	152002	2	1/4-20 Hex Nut
17	153007	2	1/4" Lock Washer
18	143163	1	1/4" x 1/8" Connector
19	143110	1	1/4" Tubing (sold by the foot)
20	143163	1	1/4" x 1/8" Connector
21	100496	1	1/8" Needle Valve
22	143238	1	1/8" Close Nipple
23	100498	1	3-Way Micro Valve – 24 VAC
24	150002	2	#6-32 x 1" Slotted Machine Screw
25	153010	2	#6 Star Washer
26	152000	2	#6-32 Hex Nut
27	330987	1	Micro Valve Support Bracket
28	152002	2	1/4-20 Hex Nut
29	153007	2	1/4" Lock Washer
30	100520	1	1/8" N.P.T. Silencer (muffler)

# Steam Coil / Mechanical Steam Damper Assembly Option

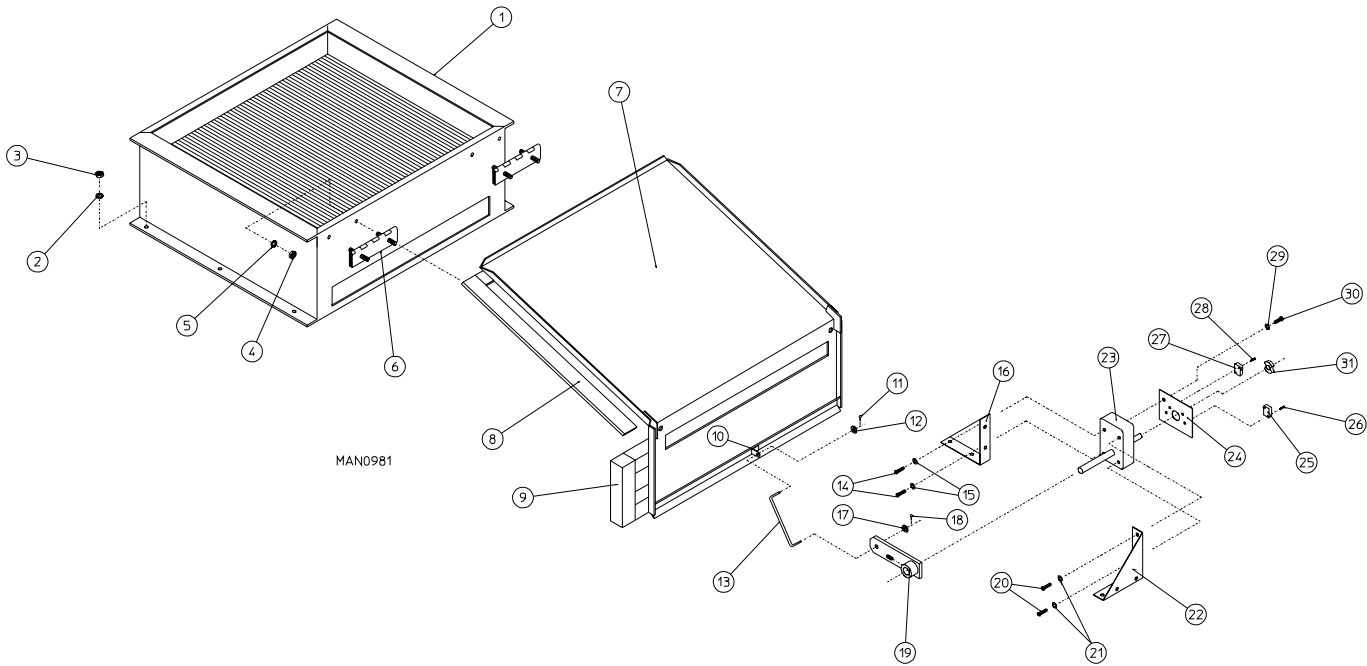

Illus. No.	Part No.	Qty.	Description
1	165011	1	Steam Coil Assembly
2	153002	6	5/16" Lock Washer
3	152004	6	5/16-18 Hex Nut
4	152002	4	1/4-20 Hex Nut
5	153007	4	1/4" Lock Washer
6	820321	2	Steam Damper Hinge Assembly
7	880781	1	Steam Damper Assembly (includes illus. nos. 7 through 10)
8	115995	66	Steam Damper Gasket (sold by the inch)
9	102350	1	Steam Damper Foam (68-1/2" length)
10	309300	1	Rod Bracket
11	154300	1	1/2" x 3/32" Cotter Pin
12	153022	1	#10 Steel Burr
13	104052	1	Mechanical Steam Damper Actuator Rod
14	150110	2	#8-32 x 1/4" Phillips Head Machine Screw
15	153012	2	#8 Star Washer
16	312315	1	Mechanical Steam Damper Motor Mount
17	153022	1	#10 Steel Burr
18	154300	1	1/2" x 3/32" Cotter Pin
19	850268	1	Mechanical Steam Damper Arm
20	150110	2	#8-32 x 1/4" Phillips Head Machine Screw
21	153012	2	#8 Star Washer
22	312315	1	Mechanical Steam Damper Motor Mount
23	104054	1	Mechanical Steam Damper Motor
24	100511	1	Mechanical Steam Damper Switch Plate
25	122120	1	Mechanical Steam Damper Switch
26	150026	2	#4-40 x 5/8" Phillips Pan Head Machine Screw
27	122120	1	Mechanical Steam Damper Switch
28	150026	2	#4-40 x 5/8" Phillips Pan Head Machine Screw
29	153012	2	#8 Star Washer
30	150102	2	#8-32 x 3/8" Pan Head Machine Screw
31	-----*	1	Mechanical Steam Damper Motor Cam

\* The mechanical steam damper motor cam is part of the mechanical steam damper motor.



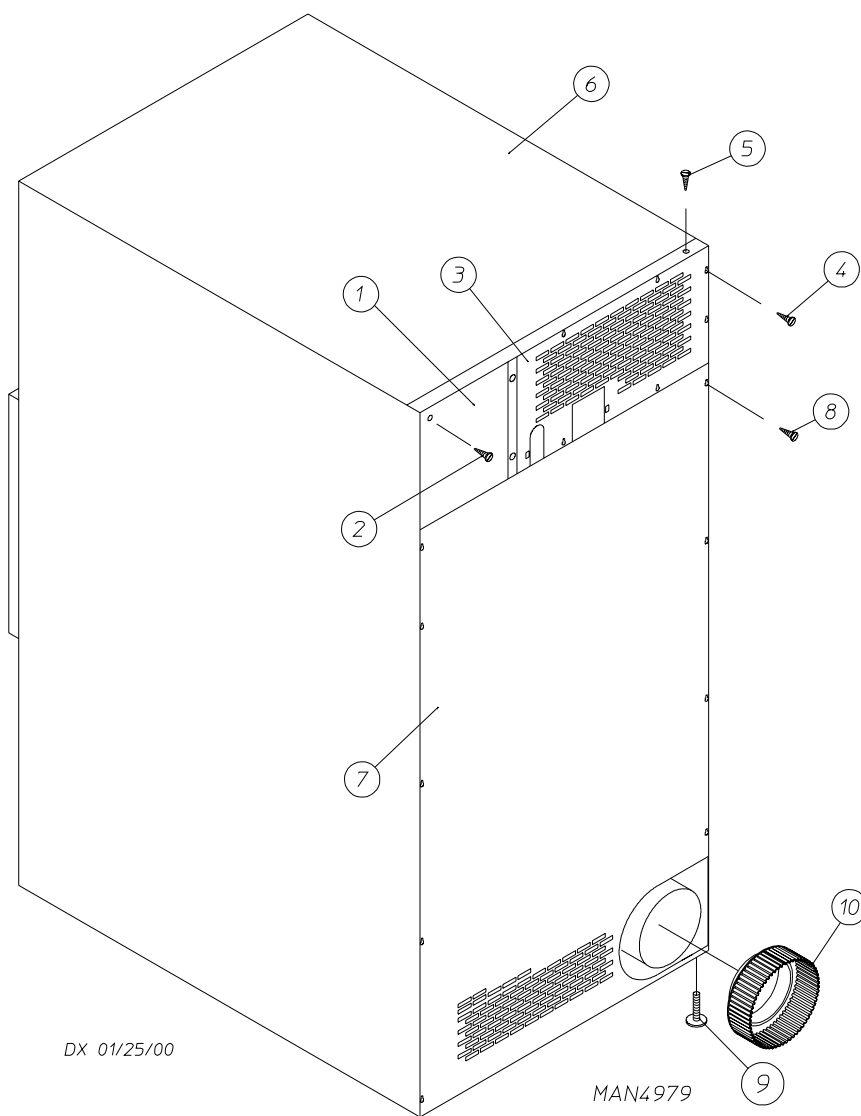

Illus. No.	Part No.	Qty.	Description
1	322809	1	Back Electrical Box Cover
2	150301	4	#8-18 x 7/16" Phillips Pan Head TEK Screw
3*	314424	1	Top Back Guard (for gas models)
	314422	1	Top Back Guard (for electric models)
4	150301	7	#8-18 x 7/16" Phillips Pan Head TEK Screw
5	150300	10	#10-16 x 1/2" Hex Washer TEK Screw
6*	312533	1	Outer Top (for gas models)
	801577	1	Outer Top (for electric models)
7	322018	1	Bottom Back Guard
8	150301	13	#8-18 x 7/16" Phillips Pan Head TEK Screw
9	103500	4	Leveling Leg
10	882099	1	8" to 10" Transition Piece

\* There is no outer top or top back guard on steam models.

## Microprocessor Coin Acceptors Listing

---

NOTE: Coin acceptors listed include optical switch.

Replacement optic switch for Hanke acceptors is Part No. 881143.

Replacement optic switch for Greenwald acceptors is Part No. 137056.

### Single Coin\*

<u>ADC Part No.</u>	<u>Nation</u>	<u>Description</u>
883363	United States	25¢ Hanke Optic Coin Acceptor with Four Studs (for models mfd. as of June 25, 2002)
882689	United States	25¢ Hanke Optic Coin Acceptor (for models mfd. between June 15, 2000 and June 25, 2002)
125100	U.S. and Canada	25¢ Greenwald Optic Coin Acceptor (for models mfd. prior to June 15, 2000)
125107	Australia	20¢ Greenwald Australian Optic Coin Acceptor
881768	Australia	\$1 Hanke Australian Optic Coin Acceptor
881604	Japan	100 Yen Hanke Optic Coin Acceptor
125103	—	0.882 Token Greenwald Optic Coin Acceptor
125121	—	0.800 Token Greenwald Optic Coin Acceptor
125133	Hong Kong	\$1 Greenwald Hong Kong Optic Coin Acceptor

### Dual Coin\*

<u>ADC Part No.</u>	<u>Nation</u>	<u>Description</u>
881842	Canada	25¢ / \$1 Hanke Dual Optic Coin Acceptor
881542	United Kingdom	1£ / 20 Pence Hanke Dual Optic Coin Acceptor
881846	France	2 / 5 Franc Hanke Dual Optic Coin Acceptor
881541	Netherlands	25¢ / 1 Guilder Hanke Dual Optic Coin Acceptor

\* Consult factory for coin acceptors not listed.

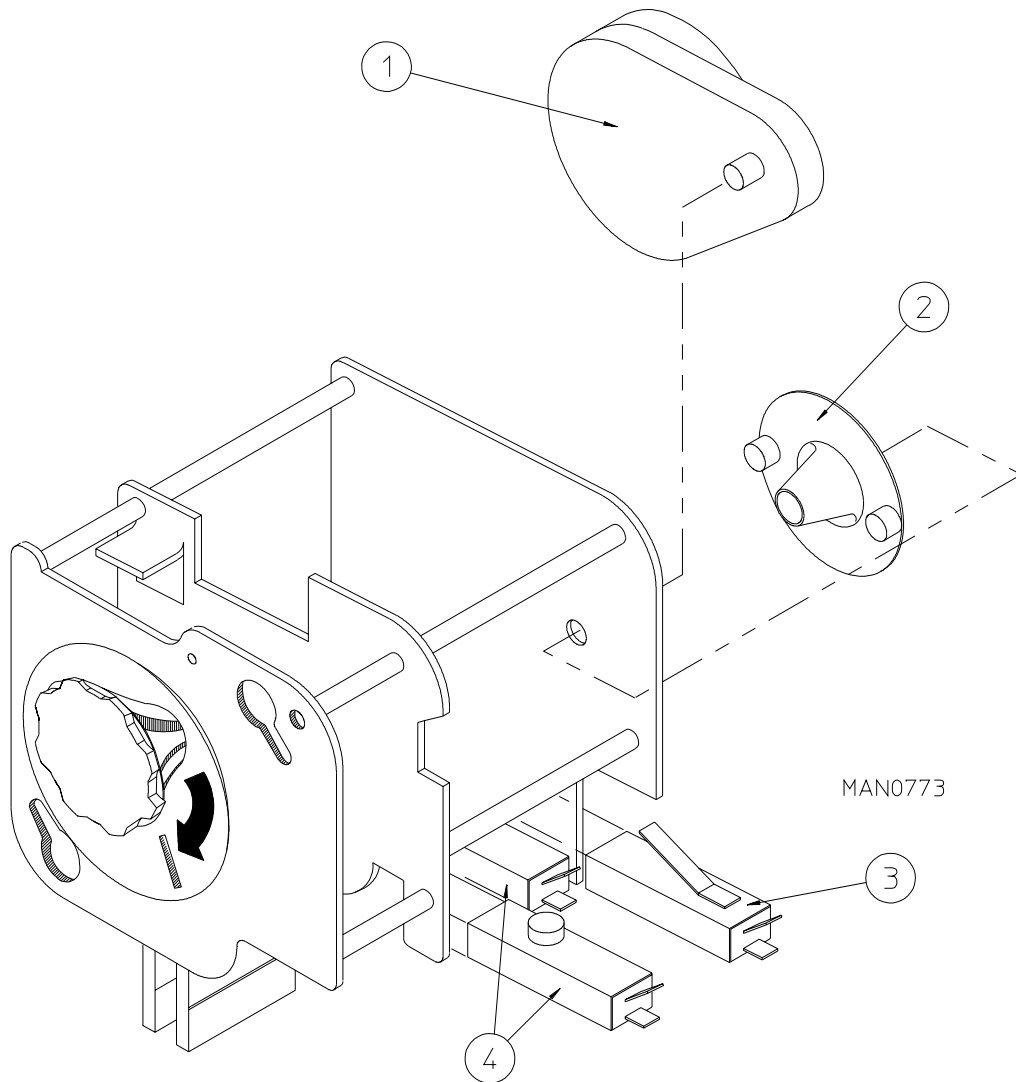

<u>Illus. No.</u>	<u>Part No.</u>	<u>Qty.</u>	<u>Description</u>
1	125541	1	1/60 RPM 24 VAC / 60 Hz Meter Motor
	125540	1	1/30 RPM 24 VAC / 50 Hz Meter Motor
2	125500	1	2-Point Cam
	125501	1	3-Point Cam
	125502	1	4-Point Cam
	125503	1	5-Point Cam
	125504	1	6-Point Cam
	125506	1	8-Point Cam
	125507	1	9-Point Cam
	125508	1	10-Point Cam
	125510	1	12-Point Cam
	3	125515	1
4	125516	2	Meter Switch "A" or "C"

kW	Voltage	Phase	Wire	Oven Assembly * Part No.	Element			Oven Wire with Crimp Terminal			Terminal Lug		Bus Bar Part No. 121011	Oven Relay	
					Qty.	kW	Part No.	Qty.	Size	Part No.	Qty.	Part No.		Cat. No.	Part No.
30	208	3∅	3 or 4	883615	6	5	120012	1	#4	882566	1	121010	1	DPA93	131358
30	240	3∅	3	824972	6	5	120013	1	#4	882566	1	121010	1	DPA73	131376
30	416	3∅	3 or 4	826391	6	5	120013	1	#8	882571	1	121010	1	DPA43	131357
30	460/480	3∅	3 or 4	824162	6	5	120013	1	#8	882572	1	121010	1	DPA43	131357
25	380	3∅	3 or 4	826391	6	5	120013	1	#8	882571	1	121010	1	DPA43	131357
24	208	3∅	3 or 4	824916	6	4	120010	1	#4	882566	1	112110	1	DPA73	131376
24	240	3∅	3	883614	6	4	120011	1	#6	882568	1	121010	1	DPA63	131369
24	460/480	3∅	3 or 4	883611	6	4	120011	1	#8	882572	1	121010	2	DPA33	131352
20	208	1∅	2	824904	5	4	120010	1	#2	883384	1	121010	2	DPA93	131358
20	240	1∅	2	883612	5	4	120011	1	#4	883385	1	121010	2	DPA93	131358
20	380	3∅	3 or 4	883613	6	4	120010	1	#8	882571	1	121010	2	DPA33	131352

\* When ordering oven assembly complete, specify 3- or 4-wire when applicable as well as if dryer has microprocessor controls.

<u>Part No.</u>	<u>Description</u>
112534	“Phase 5 OPL Program Location Summary” Label
114001	“CAUTION Exhaust / Lint Screen” Label
114006	“WARNING – Fire Hazards” Label
120800	1/4” In-Line Connector
120802	Red Butt Connector
120902	#74B Wire Nut
120903	Crimp-On Wire Nut
121499	5-1/2” Harness Tie
121500	8” Harness Tie
122804	Manometer (hydro gauge) for Measuring Gas Pressure
404502	White Brush-In-Cap Bottle Touch-Up (0.6 oz. bottle)
404506	Beige Brush-In-Cap Bottle Touch-Up Paint (0.6 oz. bottle)
404507	Cornflower Blue Brush-In-Cap Bottle Touch-Up Paint (0.6 oz. bottle)
404513	Wrinkle Blue Brush-In-Cap Bottle Touch-Up Paint (0.6 oz. bottle)
404516	Ivory Brush-In-Cap Bottle Touch-Up Paint (0.6 oz. bottle)
112146	Phase 5 Coin User’s Manual
112147	Phase 5 Non-Coin User’s Manual
882206	CD Rom (ADC Publications)

