

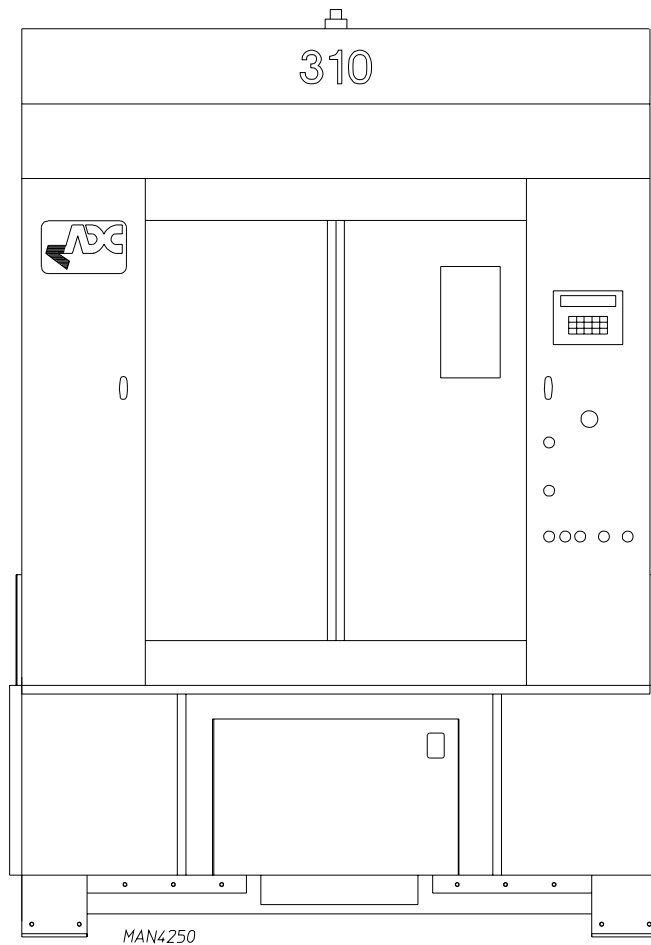

AD-310 Service Manual



American Dryer Corporation
88 Currant Road
Fall River, MA 02720-4781
Telephone: (508) 678-9000 / Fax: (508) 678-9447
e-mail: techsupport@amdry.com

Retain This Manual In A Safe Place For Future Reference

American Dryer Corporation products embody advanced concepts in engineering, design, and safety. If this product is properly maintained, it will provide many years of safe, efficient, and trouble-free operation.

ONLY qualified technicians should service this equipment.

OBSERVE ALL SAFETY PRECAUTIONS displayed on the equipment or specified in the installation/operator's manual included with the dryer.

The following "FOR YOUR SAFETY" caution **must be** posted near the dryer in a prominent location.

FOR YOUR SAFETY

Do not store or use gasoline or other flammable vapors or liquids in the vicinity of this or any other appliance.

POUR VOTRE SÉCURITÉ

Ne pas entreposer ni utiliser d'essence ni d'autres vapeurs ou liquides inflammables dans le voisinage de cet appareil ou de tout autre appareil.

We have tried to make this manual as complete as possible and hope you will find it useful. ADC reserves the right to make changes from time to time, without notice or obligation, in prices, specifications, colors, and material, and to change or discontinue models.

Important

For your convenience, log the following information:

DATE OF PURCHASE _____ MODEL NO. **AD-310** _____
DISTRIBUTORS NAME _____
Serial Number(s) _____

Replacement parts can be obtained from your distributor or the ADC factory. When ordering replacement parts from the factory, you can FAX your order to ADC at (508) 678-9447 or telephone your orders directly to the ADC Parts Department at (508) 678-9000. Please specify the dryer **model number** and **serial number** in addition to the **description** and **part number**, so that your order is processed accurately and promptly.

The illustrations on the following pages may not depict your particular dryer exactly. The illustrations are a composite of the various dryer models. Be sure to check the descriptions of the parts thoroughly before ordering.

"IMPORTANT NOTE TO PURCHASER"

Information must be obtained from your local gas supplier on the instructions to be followed if the user smells gas. These instructions must be posted in a prominent location near the dryer.

IMPORTANT

YOU MUST DISCONNECT and LOCKOUT THE ELECTRIC SUPPLY and THE GAS SUPPLY or THE STEAM SUPPLY BEFORE ANY COVERS or GUARDS ARE REMOVED FROM THE MACHINE TO ALLOW ACCESS FOR CLEANING, ADJUSTING, INSTALLATION, or TESTING OF ANY EQUIPMENT per OSHA (Occupational Safety and Health Administration) STANDARDS.

“Caution: Label all wires prior to disconnection when servicing controls. Wiring errors can cause improper operation.”

«Attention: Lors des opérations d'entretien des commandes étiqueter tous fils avant de les déconnecter. Toute erreur de câblage peut être une source de danger et de panne.»

CAUTION

DRYERS SHOULD NEVER BE LEFT UNATTENDED WHILE IN OPERATION.

WARNING

**CHILDREN SHOULD NOT BE ALLOWED TO PLAY ON OR NEAR THE DRYER(S).
CHILDREN SHOULD BE SUPERVISED IF NEAR DRYERS IN OPERATION.**

FOR YOUR SAFETY

**DO NOT DRY MOP HEADS IN THE DRYER.
DO NOT USE DRYER IN THE PRESENCE OF DRY CLEANING FUMES.**

WARNING

UNDER NO CIRCUMSTANCES should the door switch or the heat circuit devices ever be disabled.

WARNING

The dryer must never be operated with any of the back guards, outer tops, or service panels removed. **PERSONAL INJURY or FIRE COULD RESULT.**

WARNING

DRYER MUST NEVER BE OPERATED WITHOUT THE LINT FILTER/SCREEN IN PLACE, EVEN IF AN EXTERNAL LINT COLLECTION SYSTEM IS USED.

IMPORTANT

PLEASE OBSERVE ALL SAFETY PRECAUTIONS displayed on the equipment and/or specified in the installation and operator's manual included with the dryer.

Dryers **must not** be installed or stored in an area where it will be exposed to water or weather.

The wiring diagram for the dryer is located in the front left electrical control box area.

Table of Contents

AD-310 REFERENCE GUIDE	
Tumbler Section	3
AD-310 REFERENCE GUIDE	
Base Section	4
INTRODUCTION	5
AD-310 MACHINE OPERATION SUMMARY	5
AD-310 OPERATOR CONTROLS/INDICATORS	5
AD-310 MACHINE OPERATION TROUBLESHOOTING INFORMATION	8
SECTION I	
SAFETY PRECAUTIONS	16
SECTION II	
ROUTINE MAINTENANCE	18
A. Cleaning	18
B. Lubrication	20
C. Adjustments	21
SECTION III	
SPECIFICATIONS and DIMENSIONS	22
A. Specifications (Gas and Steam Models)	22
B. Dimensions	23
SECTION IV	
INSTALLATION REQUIREMENTS	27
A. Enclosure/Air Supply/Exhaust Requirements	27
B. Electrical and Gas Requirements	28
SECTION V	
COMPONENT DESCRIPTION/REPLACEMENT	29
A. Heat Section	29
B. Troubleshooting The Direct Spark Ignition (DSI) System	33
C. Natural Gas and L.P. (Liquid Propane) Gas Conversion Instructions	45
D. Steam Coil System Operation	47
E. Sprinkler System Description	52
F. Tilting System Description	58
G. Air Jet Assembly	65
H. Blower (Squirrel Cage Fan) Motor Assembly	67
I. Filter and Regulator Assembly	74
J. Door Systems	75
K. Control and Electrical System	82
L. Tumbler (Basket) System	96

SECTION VI
TROUBLESHOOTING 105

SECTION VII
PROCEDURE FOR FUNCTIONAL CHECK OF REPLACEMENT
COMPONENTS 113

AD-310 Reference Guide

(Tumbler Section)

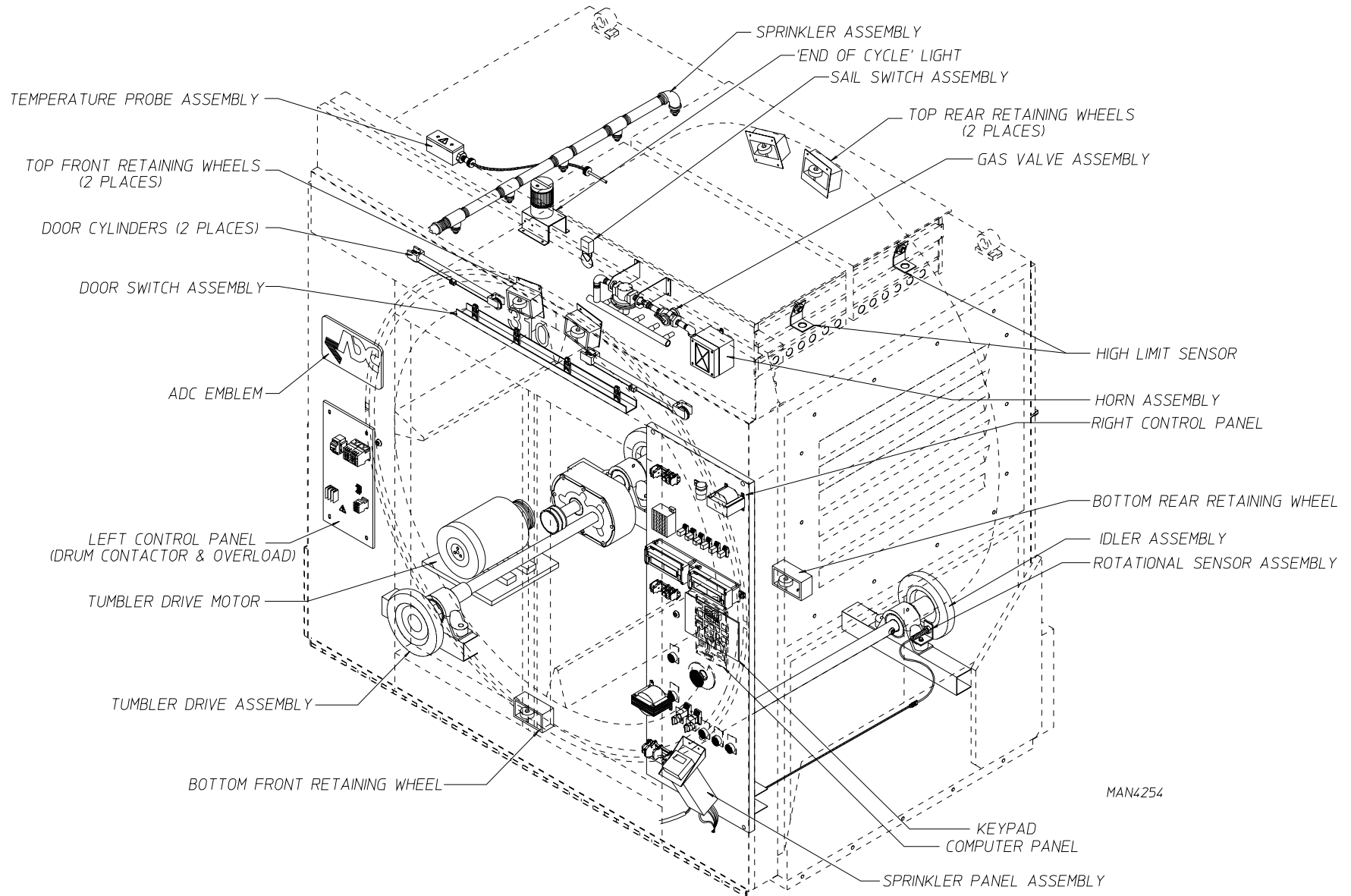

AD-310 Reference Guide

(Base Section)

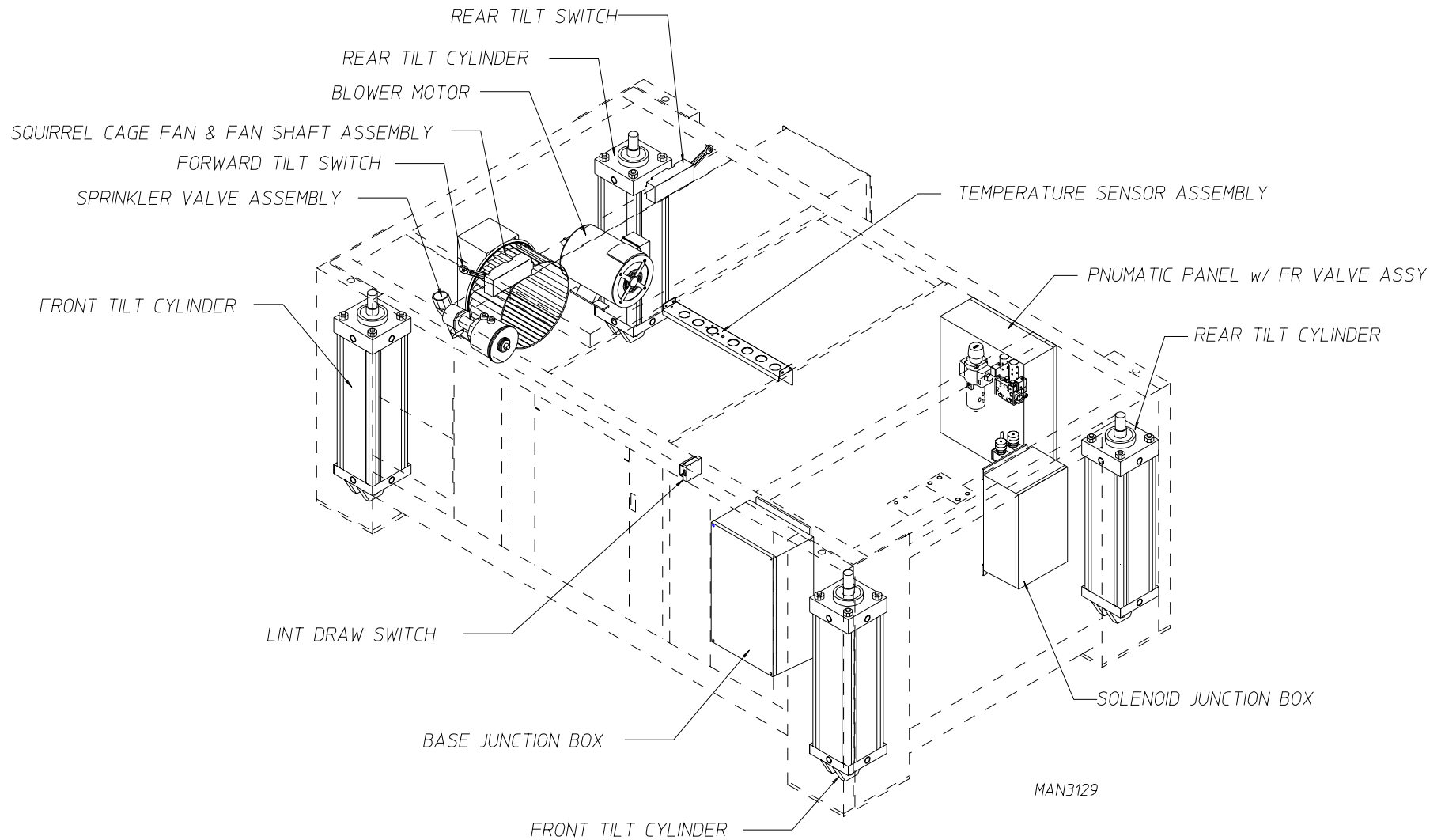

INTRODUCTION

AD-310 MACHINE OPERATIONAL SUMMARY

The model AD-310 incorporates one (1) “**EMERGENCY STOP (E-Stop) BUTTON**” located centrally on the Right Front Control Door. This “**RED**” MUSHROOM PUSH-BUTTON is “**PUSH TO STOP**” the machine and “**TURN TO RELEASE**” or “**PULL TO RELEASE**” type control device. *This button **must be** in the released mode to power the machine.* The PHASE 5 MICROPROCESSOR CONTROLLER (Computer) display will light when the “**EMERGENCY STOP (E-Stop) BUTTON**” is in the released mode. To turn “**ON**” the control voltage, press the green “**ON**” push-button located on the Right Front Control Door.

The dryer has two (2) electronic controllers:

PHASE 5 MICROPROCESSOR CONTROLLER (Computer) - for drying material

MICRO-1 PLC (Programmable Logic Controller) - for loading, unloading auto doors, and burner status monitoring

The Phase 5 Microprocessor Controller (computer) only response to keypad (touchpad) commands when the tumbler section is level with the loading doors and lint drawer/basket door closed. Likewise, the Micro-1 PLC (Programmable Logic Controller) responses to load or unload selections when the dryer is not drying material.

AD-310 OPERATOR CONTROLS/INDICATORS

The Right Front Control Door incorporates the following operator controls/indicators:

EMERGENCY STOP (E-Stop) BUTTON (Push To Stop/Turn or Pull To Release)

JOG (Forward/Reverse Push-Buttons)

UNLOAD/DRY / LOAD (Selector Switch)

TILT FUNCTION (Off - On Selector Switch)

HEATER FAULT (Indicator/Reset Push-Button)

CONTROL POWER (Indicator/Control Power On Push-Button)

CONTROL POWER (Off Push-Button)

EMERGENCY (E-Stop) STOP BUTTON (Push To Stop/Turn To Release or Pull To Release)

This "red" mushroom push-button, located in the center of the Right Front Control Door almost directly under the Phase 5 Microprocessor Controller (computer) is a "Push To Stop" and "Turn To Release" type push-button. This button **must be** in the released mode to power the machine (enable the machine to run).

JOG (Forward/Reverse Push-Buttons)

These two (2) push-buttons, located towards the left side of the Right Front Control Door, are for either loading or unloading the tumbler. "JOG" functions are only enabled when the tumbler section is in a tilted position.

NOTE: There is a PLC (Programmable Logic Controller) controlled "DWELL TIME" between forward jog or reverse jog selection to prevent plug starting the tumbler drive motor.

LOAD / DRY / UNLOAD (Three [3] Position Selector Switch)

TILT (Off - On) (Two [2] Position Selector Switch)

The "LOAD / DRY / UNLOAD" and "TILT (Off - On)" selector switches work in conjunction with each other. If the "TILT" selector is in the "OFF" position, an "UNLOAD" or "LOAD" selection will open the front horizontal doors, allowing an operator to load or unload the tumbler in the level position.

NOTE: The "JOG" feature will respond in the level position. The Lint Drawer **must be** closed for the "JOG" feature to operate.

If the "TILT" selector is in the "ON" position, an "UNLOAD" selection will open the front vertical doors and tilt the tumbler section towards the front (Rear Up). Likewise, a "LOAD" selection will the front horizontal doors and tilt the tumbler section towards the rear (Front Up).

The "DRY" selection will bring the tumbler section to a level position and close the front horizontal doors. Once **ALL** safe conditions are met (i.e., front doors closed, lint drawer closed, machine level), an operator will be able to select a drying cycle on the Phase 5 Microprocessor Controller's (computer) keypad (touchpad), located on the Right Front Control Door. Refer to the Phase 5 Operator's manual for details.

HEATER FAULT (Indicator/Reset Button) *for GAS MODELS ONLY*

During a drying cycle the PLC (Programmable Logic Controller) monitors the status of the Phase 5 Microprocessor Controller's (computer) "Heat On/Off" signal, the control status of the front and rear gas valves, and the state of both the front and rear burner air flow switches. If a fault is sensed, the "HEATER FAULT" indicator and "END OF CYCLE" indicator will begin to flash at a rate of one (1) per second. Both indicators will flash until the operator presses the "HEATER FAULT" reset push-button. For more details on "HEATER FAULT" refer to the operation section in this manual.

CONTROL POWER (On)

This "GREEN LIGHTED OPERATOR," located on the Right Front Control Door, is for enabling the dryer's control voltage. This push-button **must be** "ON" for drying or load/unload function to occur.

CONTROL POWER (Off)

This "**RED LIGHTED OPERATOR**," located on the Right Front Control Door, is for disabling the dryer's output control voltage. This push-button is mainly for use as a troubleshooting function.

END OF CYCLE / HEATER FAULT INDICATOR / AIR JET

This amber colored indicator located on the front/top of the dryer has two (2) functions:

1. To indicate that a drying cycle has been completed and that the dried material is ready for attention. Once the dryer is attended (i.e., lint drawer is opened, or the "UNLOAD - DRY- LOAD" selector is turned to either the "UNLOAD" or "LOAD" position and the vertical doors open) the indicator will go off.
2. To indicate that a "HEATER FAULT" has occurred.

Note that during a "HEATER FAULT" this indicator will flash in conjunction with the "HEATER FAULT" indicator/reset push-button" located on the Right Front Control Door. Refer to the "HEATER FAULT" Indicator/Reset Push-Button explanation on the **previous page (page 6)**, for more information concerning "HEATER FAULTS."

3. The Air Jet will be activated at the end of the drying cycle when the "END OF CYCLE" light has been energized. The Air Jet will remain active for approximately thirty (30) seconds to remove lint which may have accumulated on the Blower Wheel (squirrel cage).

AD-310 MACHINE OPERATION TROUBLESHOOTING INFORMATION

END OF CYCLE/HEATER FAULT INDICATOR

The “END OF CYCLE” light located on the top/front of the dryer, is triggered by the Air Jet Signal of the Phase 5 Microprocessor Controller (computer) to the input of the PLC (Programmable Logic Controller). If this signal is not sensed by the PLC the light will not turn on. The “1-second flashing” is accomplished by a “Flasher Module” located on the Main Control Panel in the Right Front Control Cabinet. Refer to the electrical blueprints included with this machine for detailed signal routing.

The “HEATER FAULT” signal is an output of the PLC (Programmable Logic Controller) to the “END OF CYCLE” light. A “HEATER FAULT” is an indication that a malfunction has occurred in the “Gas Heat Circuit” and needs attention. Refer to the “HEATER FAULT” explanations on **page 10 and page 11** for more information on this subject.

If this “END OF CYCLE” light fails to display at the end of every cycle;

1. Check the bulb.
2. Check voltage to the bulb (24 VAC).
3. Refer to the ladder diagram and the schematics provided with this machine for detailed signal information for higher level troubleshooting.

JOG (Forward / Reverse Push-Button)

Forward “JOG” is in the clockwise (CW) direction and Reverse “JOG” is in the counterclockwise (CCW) direction.

There is a seven (7) second dwell (delay) time between a selection of a different rotation direction. This delay is to prevent plug starting the tumbler drive motor.

If the “JOG” function does not operate in the tilted position;

1. Check that the Main Doors are fully opened.
2. Check that the Overload for the Drive Motor is in the “Start” position.
3. Check that the Overload for the Tumbler Motor is in the “Start” position.
4. Check that the Lint Drawer is closed.
5. Refer to the ladder diagram and the schematics provided with this machine for detailed signal information for higher level troubleshooting.

AIR JET

If this selection does not operate;

1. Check the air supply to the dryer (set at 80 PSI).

2. Check to see that the Air Jet L.E.D. (light emitting diode) is on at the end of the drying cycle. If the L.E.D. is not on it may be an indication of a failed Phase 5 Microprocessor Controller (computer).
3. If Air Jet L.E.D. is on then check the wiring from the Phase 5 Microprocessor Controller (computer) to the air valve.
4. Bad air valve.

LOAD / DRY / UNLOAD (Selector Switch) and TILT FUNCTION (Off - On Selector Switch)

As mentioned in the machine summary (refer to **page 6**), the “LOAD / DRY / UNLOAD” selector switch and “TILT Off - On” selector switch work in conjunction with each other.

UNLOAD or LOAD LEVEL...opens the Vertical Doors ONLY

If this selection does not operate;

1. Check that 80 PSI of compressed air is supplied to the machine and that the door solenoid is being actuated. The “Door Open” signal is generated by the PLC (Programmable Logic Controller). Refer to the PLC information included in the ladder diagrams and schematics supplied with the machine.

UNLOAD TILTED

This selection causes the front horizontal doors to open. Once the “Door Open” signal is sensed, the PLC enables the “Rear Up” solenoid to tilt the machine. Once the tumbler section releases the tilt switch, the “JOG” functions become enabled for an operator’s selection.

If the tumbler section does not tilt forward;

1. Verify that a “Door Open” signal is being sensed by the PLC (Programmable Logic Controller).
2. Check that 80 PSI of compressed air is supplied to the machine and that the “Rear Up” solenoid is being actuated by the PLC (Programmable Logic Controller).

Refer to the PLC (Programmable Logic Controller) signal information included in the ladder diagrams and schematics supplied with the machine.

LOAD TILTED

This selection causes the front horizontal doors to open. Once the “Door Open” signal is sensed, the PLC (Programmable Logic Controller). enables the “Front Up” solenoid to tilt the machine. The “JOG” functions then becomes enabled for an operator’s selection.

If the tumbler section does not tilt towards the rear;

1. Verify that a “Door Open” signal is being sensed by the PLC (Programmable Logic Controller).

2. Check that 80 PSI of compressed air is supplied to the machine and that the “Front Up” solenoid is being actuated by the PLC (Programmable Logic Controller).

Refer to the PLC (Programmable Logic Controller) signal information included in the ladder diagrams and schematics supplied with the machine.

DRY

This selection prepares the machine for a “Material Drying Command” from the Phase 5 Microprocessor Controller (computer).

NOTE: Before a drying cycle can be selected, the tumbler section *must be* in the level position and both the Front Horizontal Doors as well as the Lint Drawer *must be* closed.

The PLC (Programmable Logic Controller) senses that the machine is level by the two (2) level switches located on the left side of the base section. One (1) switch is towards the rear of the machine and the other switch is towards the front of the machine.

The PLC (Programmable Logic Controller) senses that the vertical doors are closed by the two (2) proximity switches located at the top center, of the dryer above the doors. These switches are magnetically actuated by magnets located on the doors.

The PLC (Programmable Logic Controller) senses the Lint Drawer by a push type switch located on the right side of the lint drawer door.

IMPORTANT: THE LINT DRAWER and LINT DRAWER GUARD *MUST BE* CLOSED BEFORE BRINGING THE MACHINE TO A LEVEL POSITION.

If the tumbler section does not return to a level position;

1. Verify that a “Door Closed” signal is being sensed by the PLC (Programmable Logic Controller).
2. Check that 80 PSI of compressed air is supplied to the machine and that the “Front Down” or “Rear Down” solenoid is being actuated by the PLC (Programmable Logic Controller).
3. Verify that the Lint Drawer and Lint Drawer Guard is in the closed position. This signal can be easily verified since it is a PLC (Programmable Logic Controller) input.

Refer to the PLC (Programmable Logic Controller) signal information included in the ladder diagrams and schematics supplied with the machine.

HEATER FAULT (Indicator/Reset Push-Button) *for GAS MODELS ONLY*

“HEATER FAULT” refers to a problem in the Gas Heating portion of the machine.

The PLC (Programmable Logic Controller) monitors the Phase 5 Microprocessor Controller’s (computer’s) Heat Off/On signals to the two (2) individual gas valves that supply the two (2) separate burners.

When a “HEATER FAULT” occurs within the first twenty-five (25) seconds of the drying cycle, the dryer will go to a “FILL” message on the Phase 5 Microprocessor Controller’s (computer’s) display and both the “HEATER FAULT” reset push-button and the “END OF CYCLE” light will flash.

When a “HEATER FAULT” occurs after the first twenty-five (25) seconds of the drying cycle, a “CLEAR/STOP” will be sent to the Phase 5 Microprocessor Controller (computer), a “FILL” message will be displayed on the Phase 5 Microprocessor Controller’s (computer’s) display, and both the “HEATER FAULT” reset push-button and the “END OF CYCLE” light will flash.

NOTE: If the “HEATER FAULT Reset Push-Button” is pressed any time during the PLC (Programmable Logic Controller) controlled cool down cycle, the machine will come to a stop since the machine is being attended to by a qualified operator.

“HEATER FAULT” occurs during the following conditions:

Front and/or rear or both air flow switches are in the closed position at the start of a drying cycle.

IMPORTANT: At the start of a drying cycle, the tumbler will begin to turn and a few seconds thereafter, the “FAN” signal will be asserted.

IF BOTH AIR FLOW SWITCHES **ARE NOT OPEN** AT THIS TIME THE BLOWER WILL NOT START and A “HEATER FAULT” WILL OCCUR.

Both HEATER FAULT Indicators” will flash and the machine will come to a complete halt/stop until the “HEATER FAULT” reset push-button is pressed.

ONE or BOTH BURNERS DO NOT IGNITE

The dryer has two (2) burner boxes. Each burner box has its own Gas Valve, Spark Ignitor/Flame-Probe Assembly, and DSI (Direct Spark Ignition) Module.

DSI (Direct Spark Ignition) Module

When the dryer calls for heat, and **ALL** dryer safety switches are satisfied, a 24 VAC control signal is supplied to both DSI (Direct Spark Ignition) Modules. The DSI Module L.E.D. (light emitting diode) indicators will light “**red**” for approximately 1.5-seconds of pre-purge, the L.E.D. indicators will light “**green**”. Each DSI Module will energize its’ respective gas valve and provide an 8-second spark to its’ Spark Ignitor/Flame-Probe Assembly. ***The gas in both burner boxes should ignite.*** If ignition does not occur in one or both burners after 8-seconds, the flame will not be sensed by the Spark Ignitor/Flame-Probe Assembly and the DSI Module will go into the “LOCK-OUT” mode lighting the L.E.D. (light emitting diode) indicator(s) “**red**” **continuously**. **THERE ARE NO IGNITION RETRIES BY THE DSI MODULE.** Stop the dryer at this point and restart another drying cycle. It may take several restarts to clear the gas supply piping of air.

NOTE: “HEATER FAULT” will occur during the initial set up of the machine, indicating that the burners **are not** lighting due to air in the gas line.

GAS PRESSURE

The natural gas pressure supplied to the dryer **must be** between 6-inches and 12-inches of W.C. (water column) pressure. If the supply pressure is above 12-inches water column than an external regulator **must be** installed to reduce the gas supply pressure to between 6-inches and 12-inches of water column.

Once the flame has been established in both burner boxes, the natural gas outlet manifold pressure measured at each gas valve pressure tap **must be** 3-1/2 inches W.C. (water column) pressure. Connect a water tube manometer to the 1/8" F.P.T. gas pressure tap on the downstream side of each gas valve. There is a pressure regulator in both gas valves so the manifold pressure can be adjusted to 3-1/2" water column (W.C.). Unscrew the slotted regulator cover which is located on the top of each gas valve, and turn the regulator adjustment screw located underneath the cover (clockwise [CW] to increase manifold pressure and counterclockwise [CCW] to decrease manifold pressure).

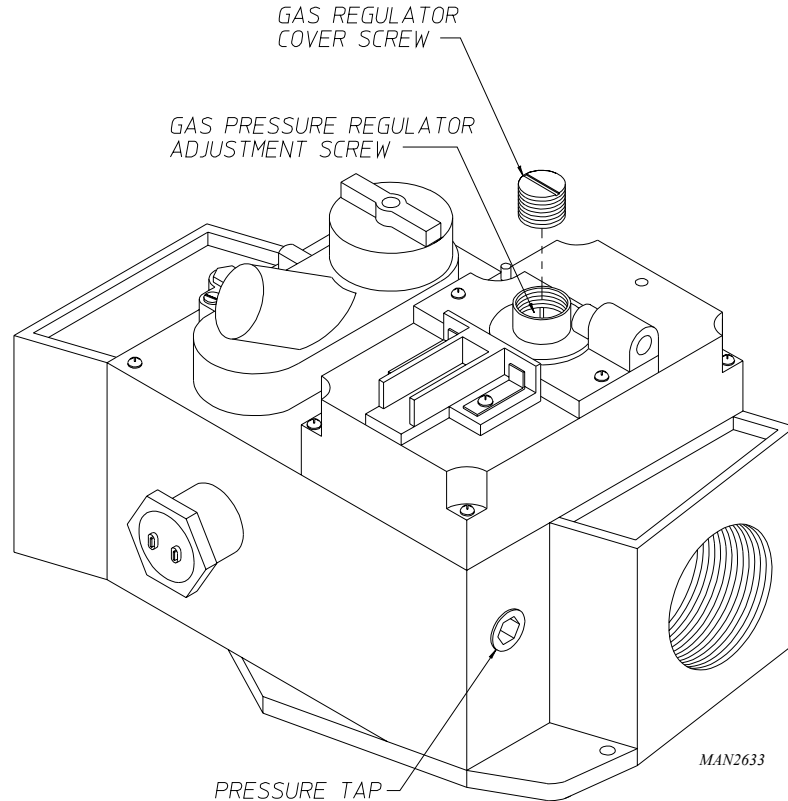

The L.P. (liquid propane) gas pressure measured at each gas valve pressure tap **must be** 11-inches water column (W.C.) pressure, when the flame is established in both burner boxes. There is no means to adjust this pressure supplied with the dryer so the downstream L.P. pressure regulator **must be** adjusted to provide the 11-inch water column (W.C.) outlet manifold pressure. Connect a water tube manometer to the 1/8" F.P.T. gas pressure tap on the downstream side of each gas valve to measure the manifold pressure.

IMPORTANT INFORMATION

Once the Blower Motor starts, both the FRONT AIR FLOW SWITCH and the REAR AIR FLOW SWITCH must pull in to indicate that there is sufficient air flow through the machine for safe ignition of both the Front Burner and the Rear Burner.

Refer to the system ladder diagram for "HEAT" signal information. There are several safety devices that *must be* satisfied prior to ignition. Any one of these safety devices can cause NO IGNITION, therefore a "HEAT FAULT"...i.e.,

- FRONT AIR FLOW SWITCH**
- REAR AIR FLOW SWITCH**
- EXHAUST HI-LIMIT SWITCH**
- FRONT BURNER INTAKE HI-LIMIT SWITCH**
- REAR BURNER INTAKE HI-LIMIT SWITCH**
- DEFECTIVE ELECTRICAL HEAT CIRCUIT**

ONE (1) BURNER *WILL NOT IGNITE AT THE BEGINNING OF A CYCLE*

This condition can be caused by the following:

- DEFECTIVE DSI (Direct Spark Ignition) MODULE
- DEFECTIVE SPARK IGNITOR/FLAME-PROBE ASSEMBLY
- DEFECTIVE GAS VALVE
- INSUFFICIENT GAS PRESSURE
- DEFECTIVE ELECTRICAL HEAT CIRCUIT

Refer to the ladder diagram and the schematics provided with this machine for reference to the above listed information.

ONE (1) BURNER *WILL NOT IGNITE DURING A DRYING CYCLE*

This condition can be caused by the following:

- DEFECTIVE DSI (Direct Spark Ignition) MODULE
- DEFECTIVE SPARK IGNITOR/FLAME-PROBE ASSEMBLY
- DEFECTIVE GAS VALVE
- DEFECTIVE ELECTRICAL HEAT CIRCUIT
- LOSS OF GAS PRESSURE

Refer to the ladder diagram and the schematics provided with this machine for reference to the above listed information.

CONTROL POWER (Indicator/Control Power On Push-Button)

This “**GREEN LIGHTED**” push-button is for enabling the 24 VAC control voltage to the control circuits of the machine. This push-button indicator **must be** “ON” for the system to load or dry material.

Refer to the ladder diagram included with the dryer for the function of this push-button in the 24 VAC control voltage latching control circuit.

CONTROL POWER (Off Push-Button)

This “**RED NON-LIGHTED**” push-button is for disabling the 24 VAC control voltage to the control circuits of the machine.

Refer to the ladder diagram included with the dryer for the function of this push-button in the 24 VAC control voltage latching control circuit.

SYSTEM LADDER DIAGRAM

The SYSTEM LADDER DIAGRAM is an overview on the electrical connections of the dryer. This diagram is for signal flow information and is a tool to direct an individual in the correct direction for troubleshooting this machine.

The dryer system is divided into a number of “electrical” sections which are as follows:

1. Right Front Control Panel

The RIGHT FRONT CONTROL PANEL is located in the Right Front Control Cabinet of the dryer. This panel is the heart of the drying system, where **ALL** control signals interface to or from this panel. The signals that interface to this panel are too many to list here, however, they are **ALL** identified on TB1 of its’ schematic diagram.

2. Right Base Electrical Enclosure

The RIGHT BASE ELECTRICAL ENCLOSURE is located towards the front of the right base section. An industrial multi-pin connector is used to connect the base section control signals to the tumbler section’s main control panel. This electrical enclosure is labeled **CAUTION, HIGH VOLTAGE IS PRESENT IN THIS ENCLOSURE** and incorporates the following electrical devices:

- The MAIN ELECTRICAL POWER to the machine
- The ELECTRICAL CONNECTION for the “OPTIONAL” SPRINKLER CIRCUIT POWER
- The THERMAL/MAGNETIC OVERLOAD and REVERSING CONTACTOR for the TUMBLER MOTOR
- The THERMAL/MAGNETIC OVERLOAD and REVERSING CONTACTOR for the BLOWER MOTOR

3. Right Base Interface Junction Box

The RIGHT BASE INTERFACE JUNCTION BOX is located towards the rear of the right base section and is used as a central location to interface the base section electrical components to the TILTING tumbler section. An industrial multi-pin connector is used to connect the base section control signals to the tumbler section’s main control panel. The control signals incorporated in the Right Base Interface Junction Box are:

SOLENOID CONTROL

- Front Up / Front Down
- Rear Up / Rear Down
- Open Front Door
- Supply Air Enable
- Air Jet

LINT DRAWER / GUARD STATUS

TUMBLER TEMPERATURE and HI-LIMIT INFORMATION

TUMBLER LEVEL SENSE

- Front Level Switch
- Rear Level Switch

OPTIONAL SPRINKLER CONTROL SIGNALS

4. Optional Sprinkler Circuit

The OPTIONAL SPRINKLER CIRCUIT main control panel will be located in the left front electrical enclosure. If a SPRINKLER OPTION is included with the dryer, this panel will include an “AUTOMATIC EMERGENCY STOP” feature. This feature requires that the Sprinkler Circuit be functional for the dryer to be powered.

NOTE: There will be a dedicated electrical connection in the Right Electrical Junction Box for the Sprinkler Circuit.

SECTION I

SAFETY PRECAUTIONS

CAUTION: The dryer *should never* be left unattended while in operation.

WARNING: For your safety, the information in this manual *must be* followed to minimize the risk of fire or explosion or to prevent property damage, personal injury, or loss of life.

WARNING: The dryer **must never be operated with any of the back guards, outer tops, or service panels removed. PERSONAL INJURY or FIRE COULD RESULT.**

1. **DO NOT** store or use gasoline or other flammable vapors and liquids in the vicinity of this or any other appliance.
2. Purchaser/user should consult the local gas supplier for proper instructions to be followed in the event the user smells gas. The instructions **should be** posted in a prominent location.
3. WHAT TO DO IF YOU SMELL GAS...
 - a. **DO NOT** try to light any appliance.
 - b. **DO NOT** touch any electrical switch.
 - c. **DO NOT** use any phone in your building.
 - d. Clear the room, building, or area of **ALL** occupants.
 - e. IMMEDIATELY call your gas supplier from a neighbor's phone. Follow the gas supplier's instructions.
 - f. If you **cannot** reach your gas supplier, call the fire department.
4. Installation and service **must be** performed by a qualified installer, service agency, or gas supplier.
5. Dryer(s) **must be** exhausted to the outdoors.
6. Although ADC produces a very versatile machine, there are some articles that, due to fabric composition or cleaning method, **should not** be dried in it.

WARNING: Dry only water-washed fabrics. **DO NOT** dry articles spotted or washed in dry cleaning solvents, a combustible detergent, or "all purpose" cleaner.
EXPLOSION COULD RESULT.

WARNING: **DO NOT** dry rags or articles coated or contaminated with gasoline, kerosene, oil, paint, or wax.
EXPLOSION COULD RESULT.

WARNING: *DO NOT* dry mop heads. Contamination by wax or flammable solvent will create a fire hazard.

WARNING: *DO NOT* use heat for drying articles that contain plastic, foam, sponge rubber, or similarly textured rubberlike materials. Drying in a heated basket (tumbler) may damage plastics or rubber and also may be a fire hazard.

7. A program **should be** established for the inspection and cleaning of lint in the burner area, exhaust duct work, and area around the back of the dryer. The frequency of inspection and cleaning can best be determined from experience at each location.

WARNING: The collection of lint in the burner area and exhaust duct work can create a potential fire hazard.

8. For personal safety, the dryer **must be** electrically grounded in accordance with local codes and/or the NATIONAL ELECTRIC CODE ANSI/NFPA NO. 70-LATEST EDITION.

NOTE: Failure to do so will VOID THE WARRANTY.

9. **UNDER NO CIRCUMSTANCES** should the dryer door switches, lint drawer switch, or heat safety circuit, ever be disabled.

WARNING: PERSONAL INJURY or FIRE COULD RESULT.

10. This dryer is not to be used in the presence of dry cleaning solvents or fumes.

11. Remove articles from the dryer as soon as the drying cycle has been completed.

WARNING: Articles left in the dryer after the drying and cooling cycles have been completed can create a fire hazard.

12. **READ and FOLLOW ALL CAUTION and DIRECTION LABELS ATTACHED TO THE DRYER.**

IMPORTANT: Label **ALL** wires prior to disconnection when servicing the microprocessor controller (computer) and the ignition module. **WIRING ERRORS CAN CAUSE IMPROPER and DANGEROUS OPERATION.**

IMPORTANT: YOU MUST DISCONNECT and LOCKOUT THE ELECTRIC SUPPLY and THE GAS SUPPLY or THE STEAM SUPPLY BEFORE ANY COVERS or GUARDS ARE REMOVED FROM THE MACHINE TO ALLOW ACCESS FOR CLEANING, ADJUSTING, INSTALLATION, or TESTING OF ANY EQUIPMENT per OSHA (Occupational Safety and Health Administration) STANDARDS.

SECTION II

ROUTINE MAINTENANCE

A. CLEANING

A schedule **should be** established for periodic inspection, cleaning, and removal of lint from various areas of the dryer, as well as throughout the duct work system. The frequency of cleaning can best be determined from experience at each location. Maximum operating efficiency is dependent upon proper air circulation. The accumulation of lint can restrict this air flow. If the guidelines in this section are met, an ADC dryer will provide many years of efficient, trouble-free, and - most importantly - safe operation.

WARNING: LINT FROM MOST FABRICS IS HIGHLY COMBUSTIBLE. THE ACCUMULATION OF LINT CAN CREATE A POTENTIAL FIRE HAZARD.

WARNING: KEEP DRYER AREA CLEAR AND FREE FROM COMBUSTIBLE MATERIALS, GASOLINE, and OTHER FLAMMABLE VAPORS and LIQUIDS.

NOTE: REMOVE POWER FROM THE MACHINE BEFORE PERFORMING ANY MAINTENANCE IN THE MACHINE.

NOTE: Suggested time intervals shown are for average usage which is considered six (6) to eight (8) operational (running) hours per day.

SUGGESTED CLEANING SCHEDULE

EVERY THIRD or FOURTH LOAD

Clean the lint screen. A clogged lint screen will cause poor dryer performance. The lint screen is located in the lint drawer in the base of the dryer. Pull out the lint drawer, brush the lint off the lint screen, and remove the lint. Inspect the lint screen and replace if torn.

NOTE: The frequency of cleaning the lint screens can best be determined from experience at each location.

WEEKLY

Open the hinged panels on each side of the tumbler section and remove any lint accumulation from the tumbler drive motor, drive shafts, gear reducer, drive belts, drive wheels, and drive shaft bearings.

Slide the lint basket all the way out of the dryer and clean any lint accumulation off of the temperature sensor bracket, which is located above the lint basket.

WARNING: TO AVOID THE HAZARD OF ELECTRICAL SHOCK, DISCONTINUE ELECTRICAL SUPPLY TO THE DRYER.

MONTHLY

Empty the compressed air filter bowl.

Clean any lint accumulation from the gas valve and burner area at the top of the dryer, the fan (impellor/blower) motor, and the fan (impellor) bearings located in the dryer base.

EVERY 6 MONTHS

STEAM MODELS - clean the steam coil fins. We suggest using compressed air and a vacuum cleaner with brush attachment.

NOTE: When cleaning steam coil fins, be careful not to bend the fins. If fins are bent, straighten by using a fin comb, which is available from any local air conditioning supply house.

Inspect and remove any lint accumulation in customer furnished exhaust duct work system and from the dryers internal exhaust ducting.

NOTE: THE ACCUMULATION OF LINT IN THE EXHAUST DUCT WORK CAN CREATE A POTENTIAL FIRE HAZARD.

NOTE: *DO NOT* OBSTRUCT THE FLOW OF COMBUSTION and VENTILATION AIR. CHECK CUSTOMER FURNISHED BACK DRAFT DAMPERS IN THE EXHAUST DUCT WORK. INSPECT and REMOVE ANY LINT ACCUMULATION WHICH CAN CAUSE THE DAMPER TO BIND or STICK.

NOTE: When cleaning the dryer cabinet(s), avoid using harsh abrasives. A product intended for the cleaning of appliances is recommended.

Clean off any lint accumulation on top of the temperature probe and the hi-limit switch located above the lint basket.

B. LUBRICATION

MONTHLY

Check compressed air filter bowl for water. Empty by pressing the rubber petcock to the side. Additionally, check lubricator bowl for oil. If empty, remove the fill plug and add oil. (Use petroleum based 10/150 SSU misting oil.) Replace the fill plug.

CURRENT PRODUCTION

PAST PRODUCTION

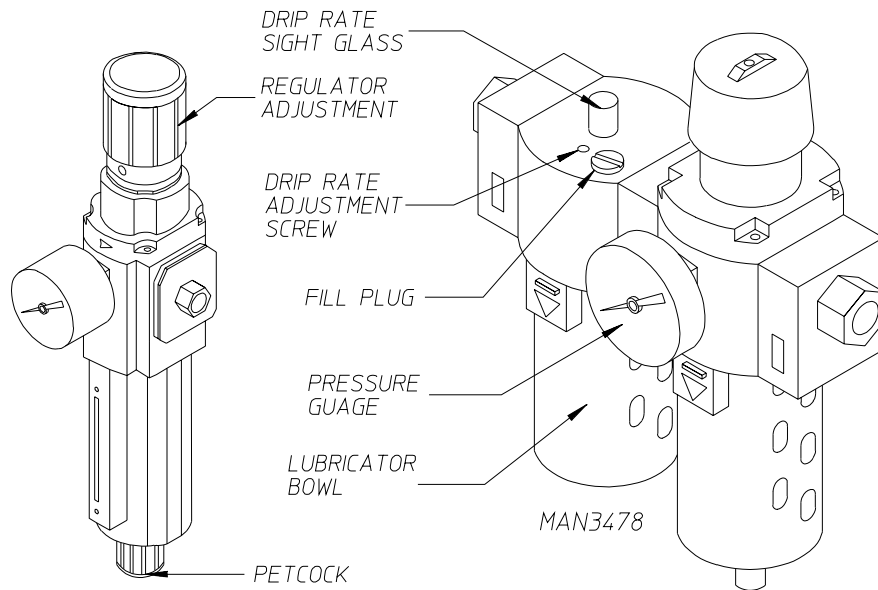

NOTE: LUBRICATOR *SHOULD BE* SET AT 1 DROP PER CYCLE.

NOTE: REGULATOR PRESSURE IS TO BE SET AT 80 PSI.

Apply high temperature grease to the four (4) 1-1/2" diameter tumbler drive shaft pillow block bearings and the two (2) 1-3/8" diameter blower shaft pillow block bearings. (Use Shell Alvania #3 grease or equivalent.)

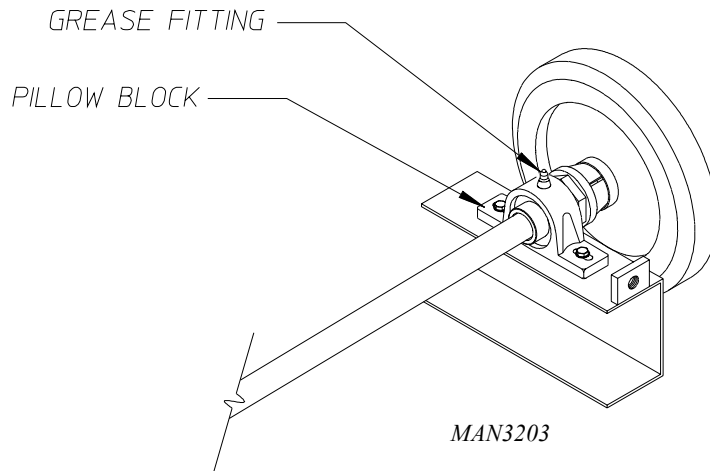

Apply grease (use Shell Alvania #3 grease or equivalent) to the tilting hinges (on 1-Way Tilt Models Only).

EVERY 6 MONTHS

Change gear oil in the tumbler shaft gear reducer.

1. Remove the drain plug (located at the bottom rear of the reducer).
2. After oil is completely drained replace the drain plug.
3. Remove the vent plug and pour in 1.4 liters of Mobil Oil DTE HH5G (I.S.O. viscosity grade 460), SAE 90, or equivalent.

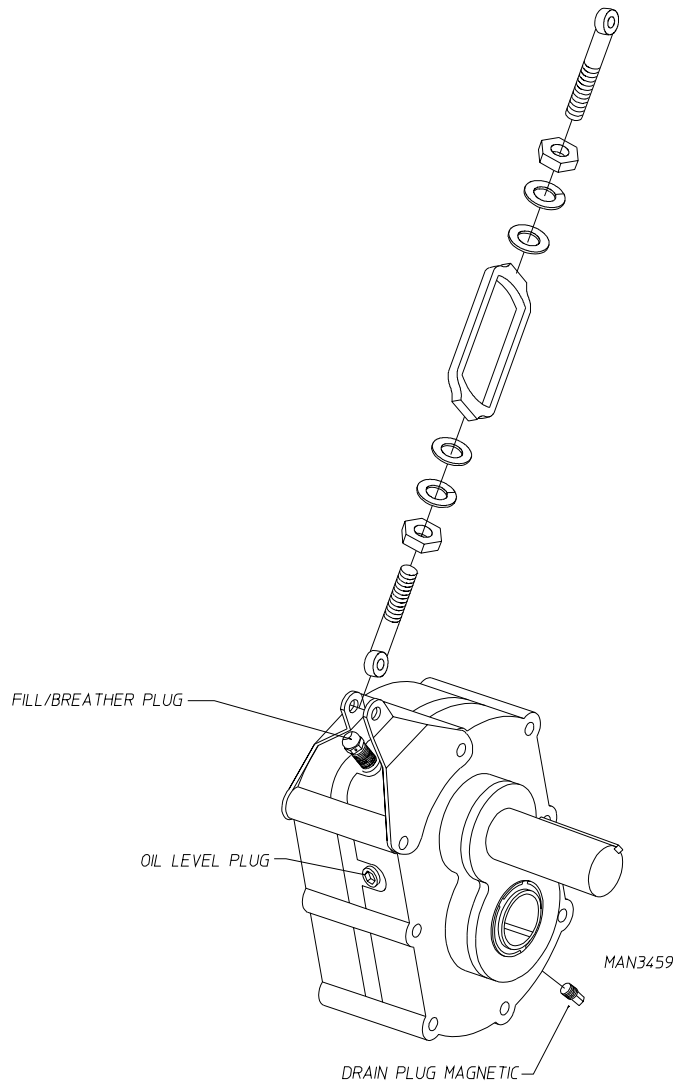

C. ADJUSTMENTS

7 DAYS AFTER INSTALLATION and EVERY 6 MONTHS THEREAFTER

Inspect bolts, nuts, screws, (bearing set screws), nonpermanent gas connections (i.e., unions, shut-off valves, orifices), and grounding connections. Fan (impellor) V-belts, along with the motor and drive belts **should be** examined and replaced if necessary. Tighten loose V-belts when necessary. Complete operational check of controls and valves. Complete operational check of **ALL** safety devices (i.e., door switches, lint drawer switch, sail switch, burner and hi-limit thermostats).

SECTION III

SPECIFICATIONS and DIMENSIONS

A. SPECIFICATIONS (Gas and Steam Models)

MAXIMUM CAPACITY (DRY WEIGHT)		310 lbs.	141 kg		
BASKET (TUMBLER) DIAMETER		62-1/2"	158.75 cm		
BASKET (TUMBLER) DEPTH		60"	152.4 cm		
BASKET (TUMBLER) VOLUME		106.5 cu. ft.	3.02 cu.m.		
DRIVE MOTOR		5 HP	3.73 kw		
BLOWER MOTOR (GAS/STEAM)		15 HP/25 HP	11.2 kw/18.7 kw		
DOOR OPENING		36-3/4" WIDE x 43" HIGH	93.3 cm x 109.2 cm		
DOOR SILL HEIGHT - LEVEL		36-1/2"	92.71 cm		
COMPRESSED AIR		80 PSI	5.63 kg/cu.m.		
COMPRESSED AIR CONNECTION		1/8" F.P.T.	.318 cm		
Gas*	VOLTAGE AVAILABLE		208-460v / 3ø / 3, 4w / 50/60 Hz		
	HEAT INPUT		1,125,000 btu/hr	283,500 kcal/hr	
	APPROX. WEIGHT (UNCRATED)		5,100 lbs.	2,313 kg	
	AIRFLOW		6,500 cfm	184 cmm	
	Inlet Pipe Size		1-1/2"	3.81 cm	
Steam*	VOLTAGE AVAILABLE		208-460v / 3ø / 3, 4w / 50/60 Hz		
	APPROX. WEIGHT (UNCRATED)		5,600 lbs.	2,540 kg	
	AIRFLOW		8,500 cfm	241 cmm	
	STEAM COMSUMPTION		BOILER HP NORMAL LOAD		
	1,153 lbs/hr	524 kg/hr	35		
	OPERATING STEAM PRESSURE		STEAM SUPPLY		STEAM RETURN
	125 psi max	8.79 kg/sq cm	2" M.P.T.	5.08 cm	2" M.P.T. 5.08 cm

Shaded areas are stated in metric equivalents.

* Dryer **must be** provided with a clean, dry, regulated 80 PSI (+/- 10 psi) air supply (equivalent volume - 11 cfm [0.3 cmh]).

NOTE: ADC reserves the right to make changes in specifications at any time, without notice or obligation.

B. DIMENSIONS

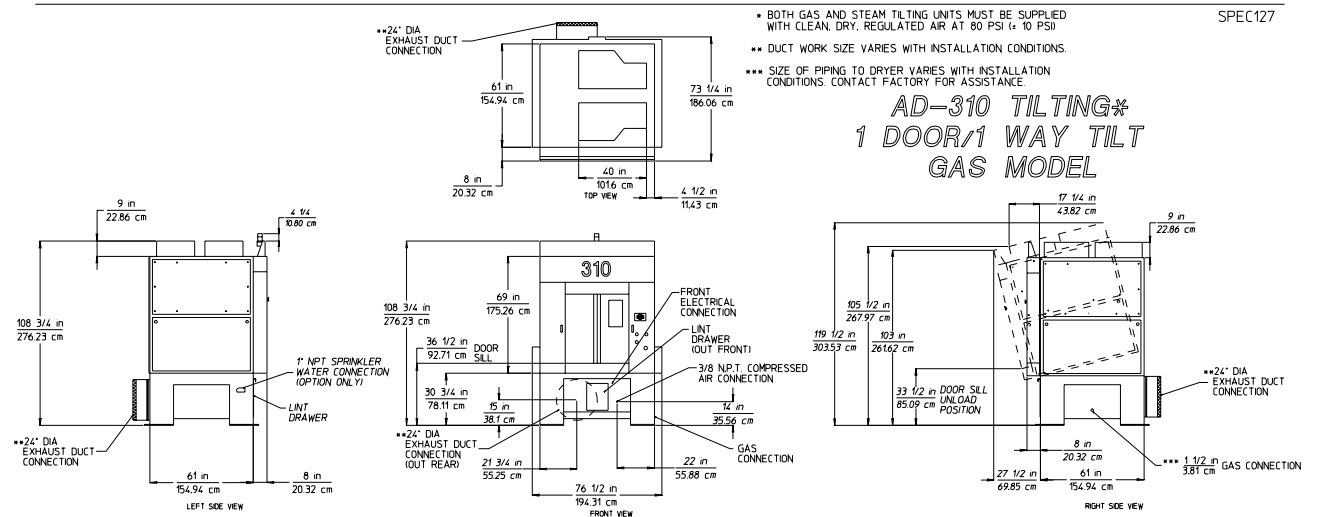
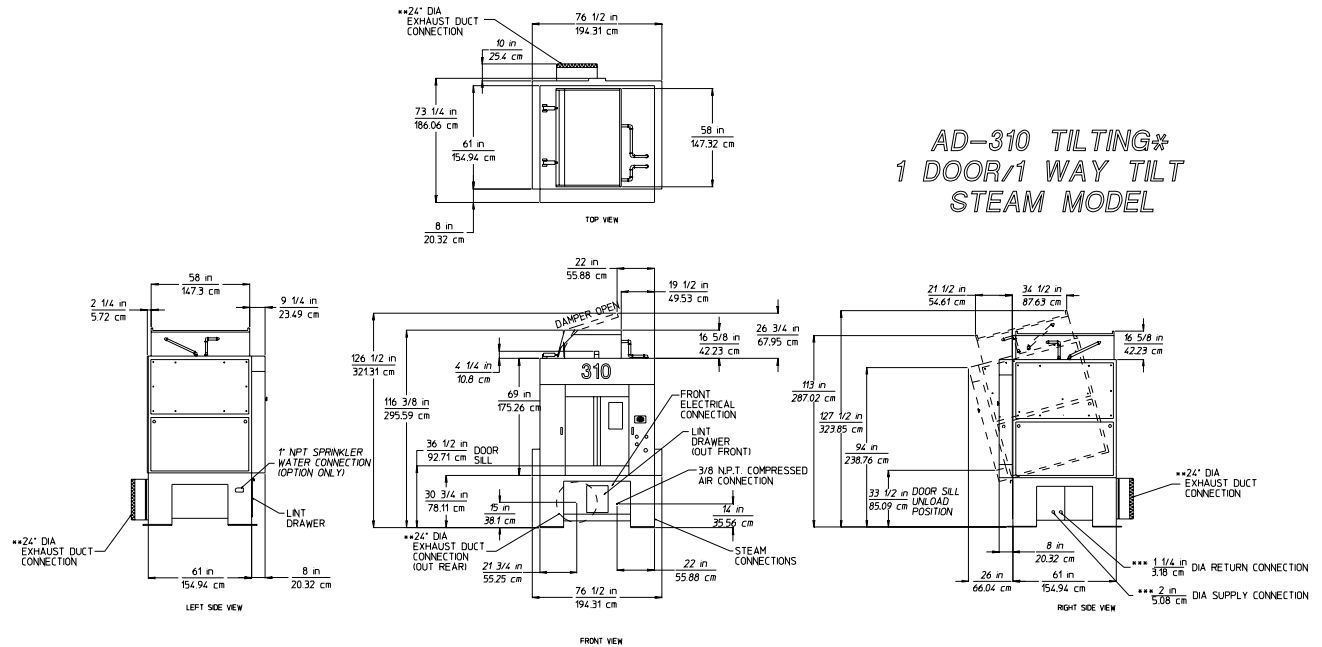

- BOTH GAS AND STEAM TILTING UNITS MUST BE SUPPLIED WITH CLEAN, DRY, REGULATED AIR AT 90 PSI (+ 10 PSI)
- DUCT WORK SIZE VARIES WITH INSTALLATION CONDITIONS.
- SIZE OF PIPING TO DRYER VARIES WITH INSTALLATION CONDITIONS. CONTACT FACTORY FOR ASSISTANCE.

SPEC127

NOTE: ADC reserves the right to make changes in specifications at any time, without notice or obligation.

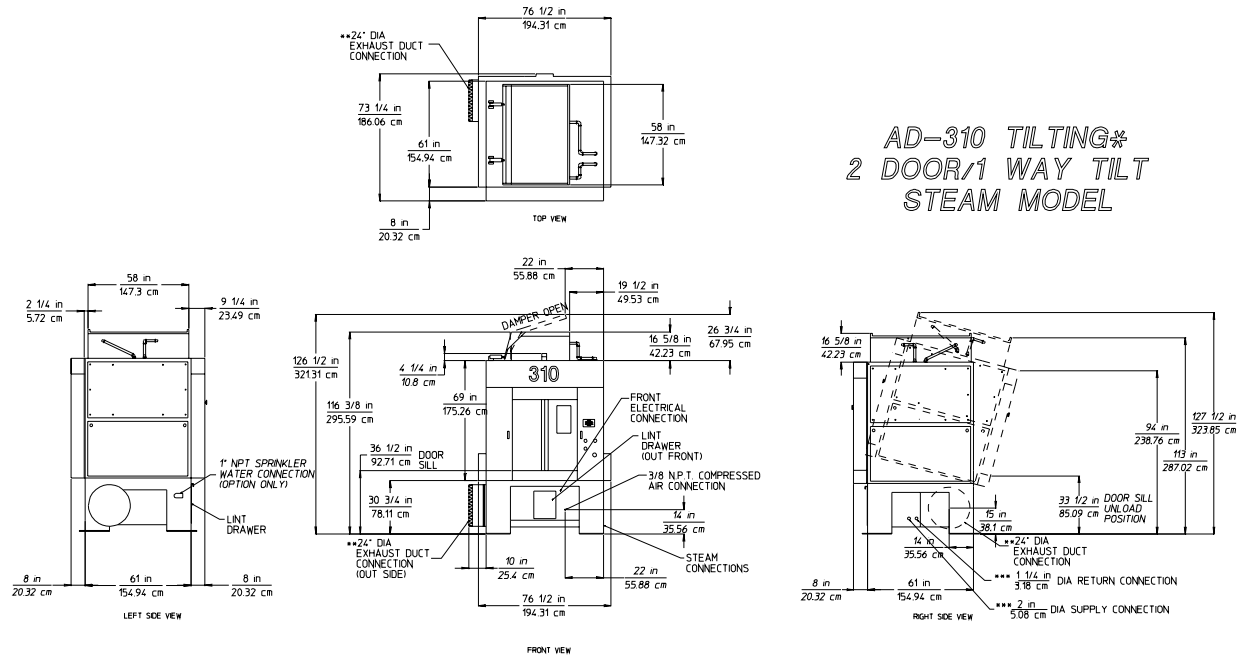

**AD-310 TILTING*
2 DOOR/1 WAY TILT
STEAM MODEL**

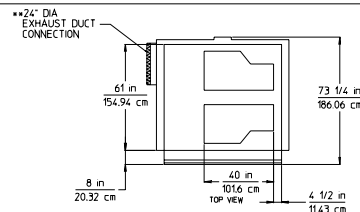

- BOTH GAS AND STEAM TILTING UNITS MUST BE SUPPLIED WITH CLEAN, DRY, REGULATED AIR AT 80 PSI (+ 10 PSI)
- DUCT WORK SIZE VARIES WITH INSTALLATION CONDITIONS.
- SIZE OF PIPING TO DRYER VARIES WITH INSTALLATION CONDITIONS. CONTACT FACTORY FOR ASSISTANCE.

SPEC124

**AD-310 TILTING*
2 DOOR/1 WAY TILT
GAS MODEL**

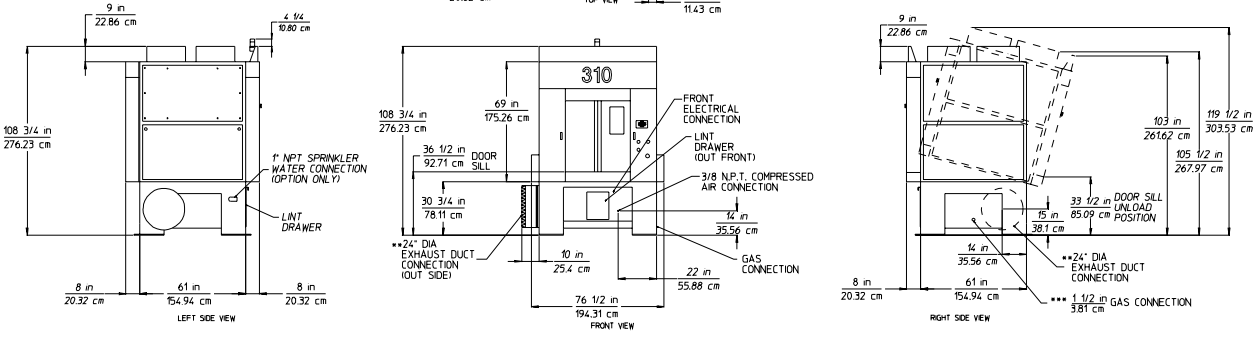

NOTE: ADC reserves the right to make changes in specifications at any time, without notice or obligation.

AD-310 TILTING* 1 DOOR/2 WAY TILT STEAM MODEL

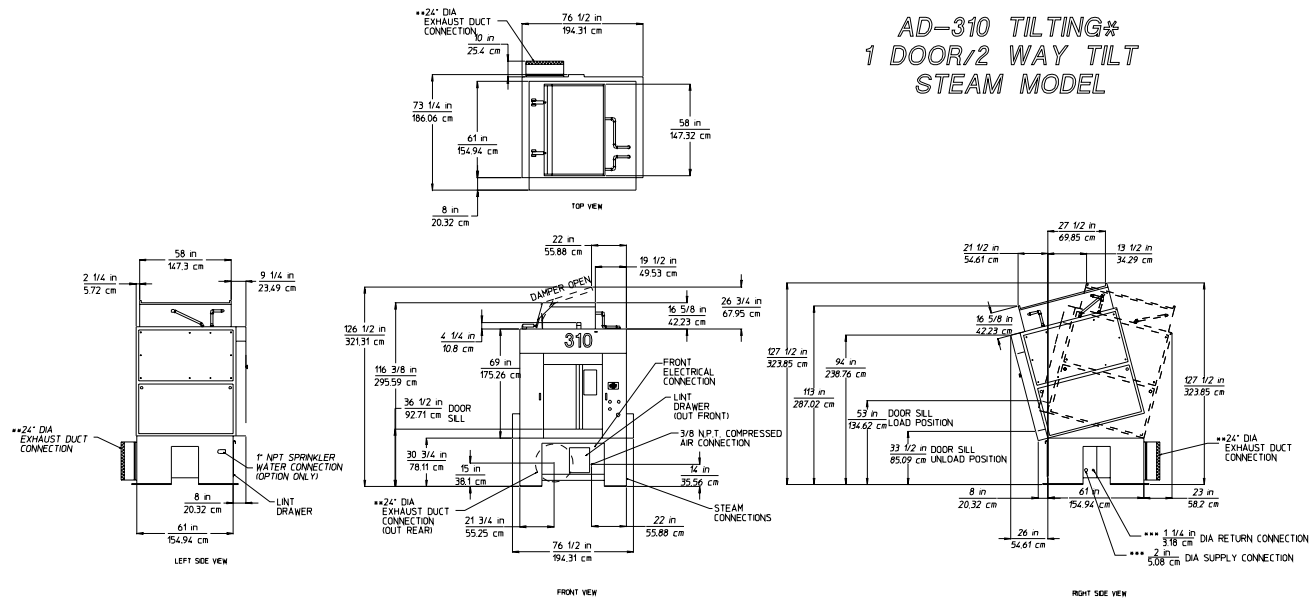

- BOTH GAS AND STEAM TILTING UNITS MUST BE SUPPLIED WITH CLEAN, DRY, REGULATED AIR AT 80 PSI (+/- 10 PSI)
 - DUCT WORK SIZE VARIES WITH INSTALLATION CONDITIONS.
 - SIZE OF PIPING TO DRYER VARIES WITH INSTALLATION CONDITIONS. CONTACT FACTORY FOR ASSISTANCE.
- SPEC126

AD-310 TILTING* 1 DOOR/2 WAY TILT GAS MODEL

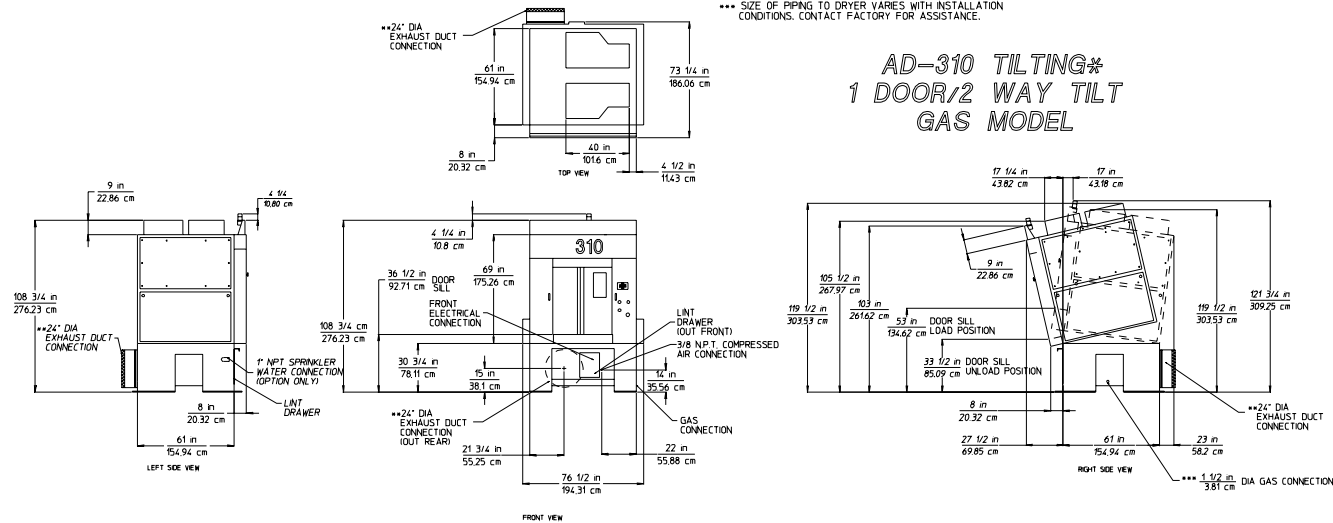

NOTE: ADC reserves the right to make changes in specifications at any time, without notice or obligation.

ADG-310 (Gas) Non-Tilt

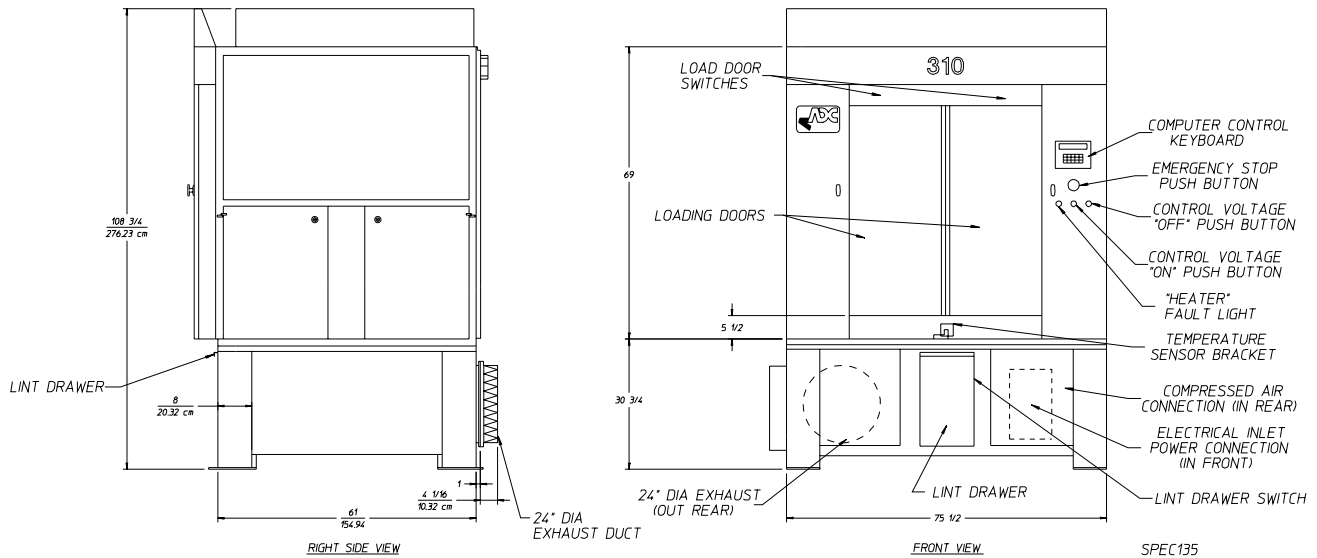
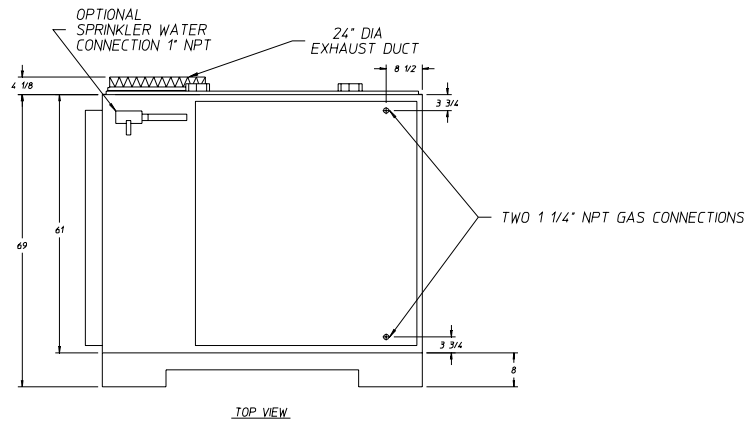

NOTE: ADC reserves the right to make changes in specifications at any time, without notice or obligation.

SECTION IV

INSTALLATION REQUIREMENTS

Installation **should be** performed by competent technicians in accordance with local and state codes. In the absence of these codes, installation **must conform** to applicable AMERICAN NATIONAL STANDARDS:

National Fuel Gas Code ANSI Z223.1-LATEST EDITION
and/or
National Electric Code ANSI/NFPA No. 70-LATEST EDITION

A. ENCLOSURE / AIR SUPPLY / EXHAUST REQUIREMENTS

NOTE: The following information is very brief and general. For detailed descriptions, refer to the AD-310 Non-Tilting Installation/Operator's Manual (ADC Part No. 112192) or the AD-310 Tilting Installation/Operator's Manual (ADC Part No. 112191).

Bulkheads and partitions around the dryer **should be** made of noncombustible materials. Allowances **should be** made for the opening and closing of the control door and lint door. Also, allowances **should be** made in the rear and sides for ease of maintenance. Refer to appropriate Installation Manual (AD-310 Non-Tilting Installation/Operator's Manual [ADC Part No. 112192] or the AD-310 Tilting Installation/Operator's Manual [ADC Part No. 112191]) for recommended distances and minimum allowances required.

When the dryer is operating, it draws in room air, heats it, passes this air through the basket (tumbler), and exhausts it out of the building. Therefore, the room air **must be** continually replenished from the outdoors. If the make-up air is inadequate, drying time and drying efficiency will be adversely affected. Ignition problems and sail switch "fluttering" problems on gas dryers may result, and you also could have premature motor failure from overheating. The air supply **must be** given careful consideration to insure proper performance of each dryer.

IMPORTANT: Make-up air **must be** provided from a source free of dry cleaning fumes. Make-up air that is contaminated by dry cleaning fumes will result in irreparable damage to motors and other dryer components.

Exhaust duct work **should be** designed and installed by a competent technician. Improperly sized duct work will create excessive back pressure which will result in slow drying, increased use of energy, and shutdown of the burner by the airflow (sail) switch, burner hi-limit or lint chamber hi-heat protector thermostat. Refer to appropriate Installation Manual (AD-310 Non-Tilting Installation/Operator's Manual [ADC Part No. 112192] or the AD-310 Tilting Installation/Operator's Manual [ADC Part No. 112191]) for more detail.

CAUTION: IMPROPERLY SIZED OR INSTALLED EXHAUST DUCT WORK CAN CREATE A POTENTIAL FIRE HAZARD.

B. ELECTRICAL REQUIREMENTS and GAS REQUIREMENTS

It is your responsibility to have **ALL** electrical connections made by a properly licensed and competent electrician to assure that the electrical installation is adequate and conforms with local and state regulations or codes. In the absence of such codes, **ALL** electrical connections, material, and workmanship **must conform** to the applicable requirements of the National Electric Code ANSI/NFPA No. 70-LATEST EDITION.

IMPORTANT: Failure to comply with these codes or ordinances and/or the requirements stipulated in this manual can result in personal injury or component failure.

The dryer installation **must meet** the AMERICAN NATIONAL STANDARD; National Fuel Gas Code ANSI Z223.1-LATEST EDITION, as well as, local codes and ordinances, and **must be** done by a qualified technician.

NOTE: Undersized gas piping will result in ignition problems and slow drying and can create a safety hazard.

The dryer **must be** connected to the type of gas (natural or L.P.) indicated on the dryer data label. If this information does not agree with the type of gas available, contact the distributor who sold the dryer or contact the factory.

The gas input ratings shown on the dryer data label are for elevations up to 2,000 feet, unless elevation requirements of over 2,000 feet were specified at the time the dryer order was placed with the factory. The adjustment for dryers in the field for elevations over 2,000 feet are made by changing the burner orifices. If this adjustment is necessary, contact the distributor who sold the dryer or contact the factory.

NOTE: Any burner changes **must be** made by a qualified technician.

C. OPERATIONAL SERVICE CHECK PROCEDURE

After performing any service or maintenance function, an operational check **should be** performed to insure that **ALL** components are performing properly.

1. Make a complete operational check of **ALL** the operating controls to insure that the timing is correct, temperature selection switches are functioning properly.
2. Make a complete operational check of **ALL** safety related circuits, door switches, hi-limit thermostat, sail switch, cycling thermostats, etc.

SECTION V

COMPONENT DESCRIPTION/REPLACEMENT

A. HEAT SECTION

The AD-310 dryer uses three (3) types of heat sources: natural gas, liquid propane (L.P.) gas, and steam. Natural Gas and L.P. (liquid propane) gas are not directly replaceable. The gas valves need to be modified to use other than the type of heat specified on the nameplate.

1. ADG-310 (gas) dryers utilizes a Direct Spark Ignition (DSI) module to monitor that a flame is established. If for some reason the flame signal is lost, the DSI module will shut off the gas valve and not retry ignition (no try to restart the flame). *A spark of approximately 14,000 volts is used to establish a flame.* The DSI (Direct Spark Ignition) module will turn the gas valve on and ignitor/flame-probe will spark for 8 seconds attempting a flame. Each time the dryer calls for heat the microprocessor controller (computer) will send a 24 VAC signal through the exhaust hi-limit, sail switch, and oven hi-limit. At that point, the DSI module will try for ignition.

DIRECT SPARK IGNITION (DSI) SYSTEM COMPONENTS/FUNCTIONS

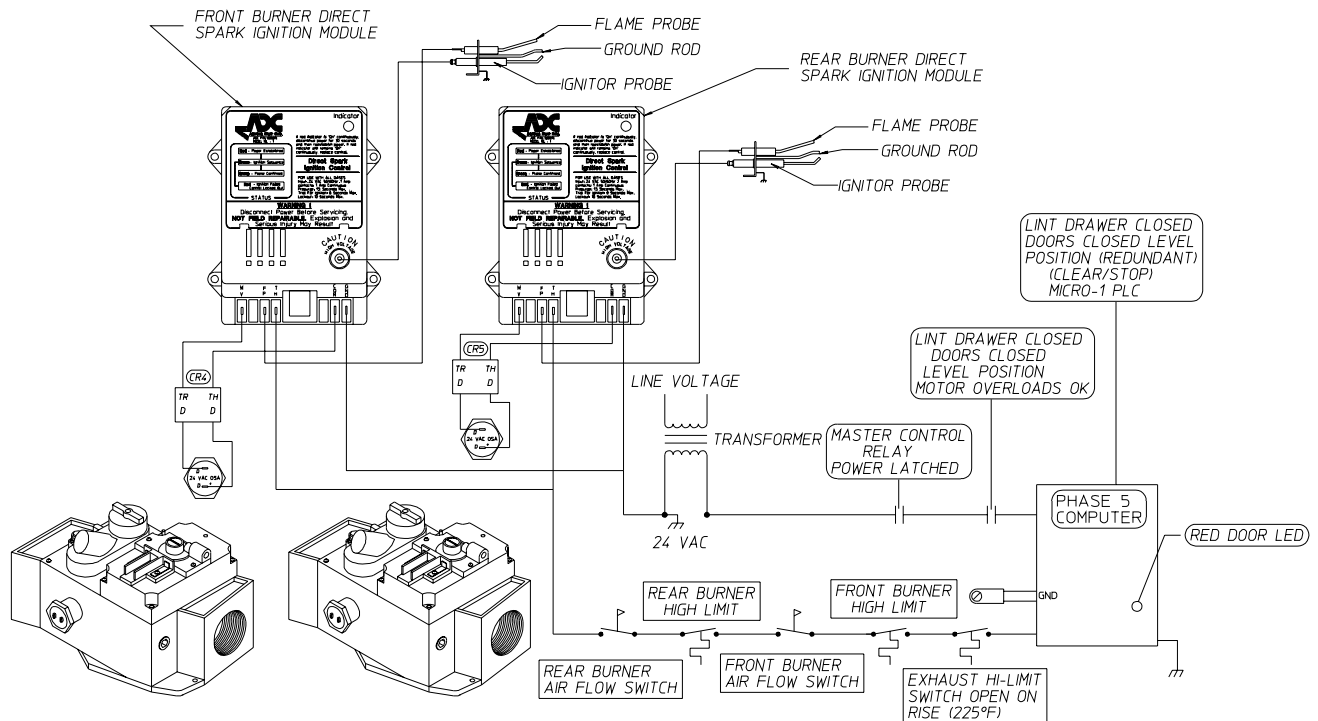

- a. The Direct Spark Ignition (DSI) Module is a 24 VAC device designed to be the "controller" of the DSI system. When activated by the dryer controls, this module constantly monitors and controls the functions of the DSI system (i.e., spark activation, gas valve off and on, flame verification, etc.). Additionally, the DSI Module has self diagnostic capabilities.

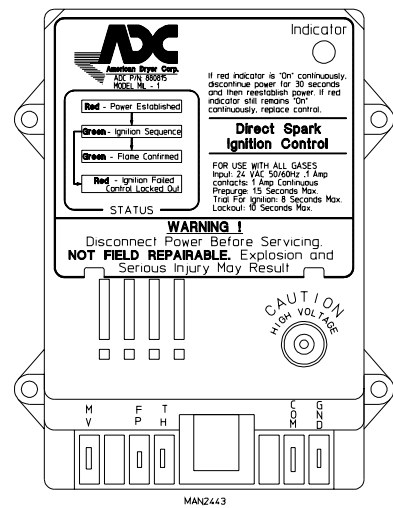

24 VAC
Direct Spark Ignition (DSI) Module

- b. The Ignitor and Flame-Probe Assembly is located in the burner flame area and is used to ignite the gas by use of a high voltage spark (approximately 14,000 volts) and to provide feedback information to the DSI (Direct Spark Ignition) Module as to whether the burner flame is evident (on).

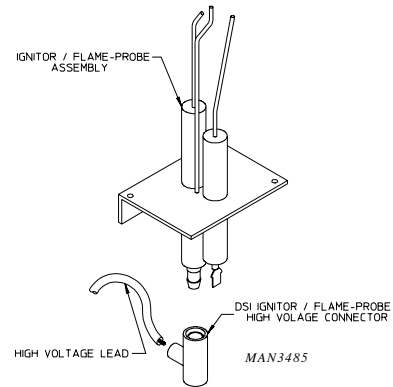

Ignitor/Flame Probe Assembly

- c. The Burner Hi-Limit Switch is a thermostat type switch located in the burner. Its function is to discontinue heat (flame) in the event of an over temperature situation (above 330° F). For dryers manufactured as of May 26, 1998, the hi-limit **must be** manually reset once the device trips.

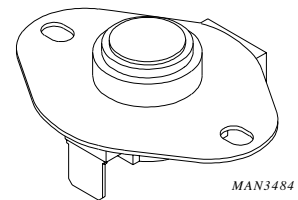

330° F Thermostat

- d. The Sail Switch Verification Assembly is located on the burner, downstream of the flame tubes. Its function is to detect whether or not there is sufficient air flow through the dryer. If the Sail Switch is not in the open position prior to a drying cycle, the blower circuit will not be activated.

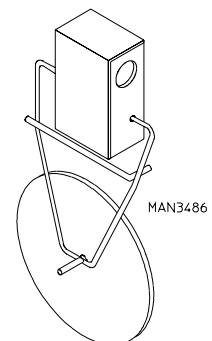

Sail Switch Verification Assembly

- e. The Tumbler Hi-Limit Switch is a thermostat type switch located above the Lint Basket. Its function is to discontinue heat (flame) in the event of an over temperature situation (above 225° F).

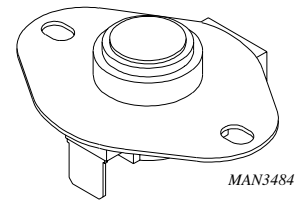

225° F. Thermostat

- f. The gas valve used in the dryer is of the redundant type which means that the gas valve is actually two (2) gas valves in one; one in series with the other. This is a safety feature which provides protection against gas flow in the event that one of the valves does not seat properly. The valve also regulates the incoming gas pressure.

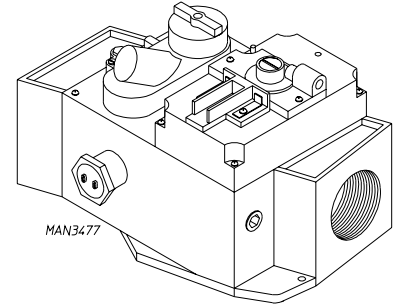

Redundant Gas Valve

NOTE: THE DSI GAS VALVES ARE NOT FIELD REPAIRABLE.

- g. Normal Operation of the Direct Spark Ignition (DSI) System (refer to the **illustration on page 29**).
- 1) The DSI (Direct Spark Ignition) System consists of a microprocessor-based control module, along with an Ignitor and Flame-Probe Assembly. This control utilizes a high voltage synchronous spark ignitor and a rectified flame sensor probe signal to locally control **ALL** basic functions in the gas burner.

On a call for heat by the dryers' controls, 24 VAC is applied to the DSI (Direct Spark Ignition) module at which time the DSI modules' L.E.D. (light emitting diode) indicator will light "**RED**" indicating that power has been established to the DSI module. Almost immediately (up to approximately 1.5-seconds [prepurge]) the indicator will light "**GREEN**," the gas valve opens and the spark burst will be evident (on) for approximately 8-seconds. The burner flame **should now be** established/confirmed.

If at this time the flame has not been established and confirmed, the DSI (Direct Spark Ignition) module will "LOCK-OUT" and the DSI modules' L.E.D. (light emitting diode) indicator will light "**RED**" and stay on continuously. To reset or cancel the "LOCK-OUT" condition, open and close the main door then restart the dryer.

Once the burner flame is established and confirmed, the DSI (Direct Spark Ignition) module indicator will light "**GREEN**," and the burner system will continue through a normal heating cycle, where the DSI (Direct Spark Ignition) system will cycle on and off as required by the dryers controls.

During the normal heating cycle, should a "FLAME-OUT" occur (i.e., severe air turbulence forces the flame away from the ignitor and flame-probe assembly), the DSI (Direct Spark Ignition) module shut the gas valve off and immediately try to reestablish the burner flame. **The DSI module will attempt to light the burner ONLY ONCE.** If flame is not established, the DSI module will "LOCK-OUT." To reset or cancel the "LOCK-OUT" condition, open and close the main door then restart the dryer.

h. ADC Direct Spark Ignition (DSI) Operation Flow Chart

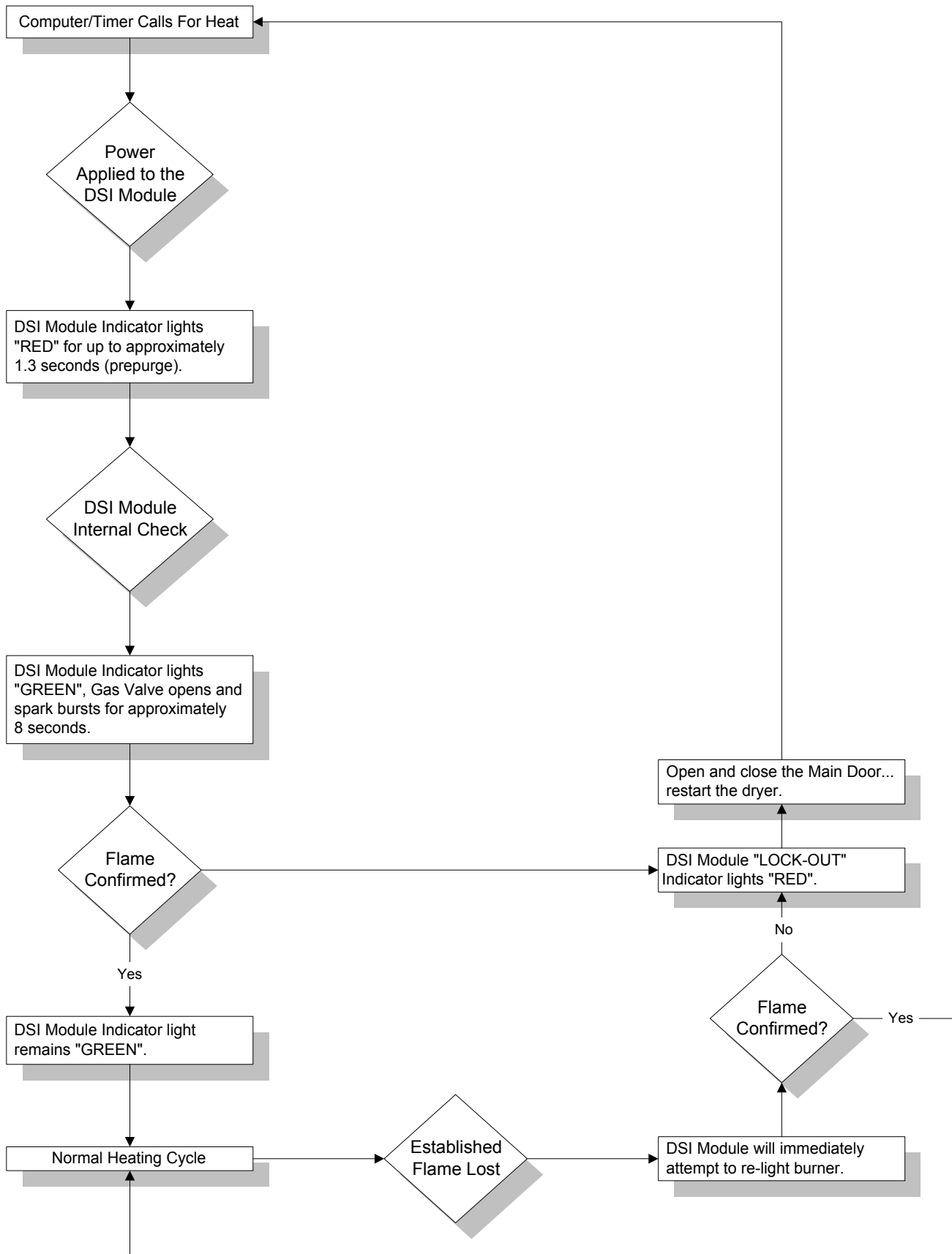

B. TROUBLESHOOTING THE DIRECT SPARK IGNITION (DSI) SYSTEM

NOTE: The troubleshooting information provided in this manual is intended for use by *qualified service technicians only*. **OBSERVE ALL SAFETY PRECAUTIONS** displayed on the equipment or specified in the AD-310 Non-Tilting Installation/Operator's Manual (ADC Part No. 112192) or the AD-310 Tilting Installation/Operator's Manual (ADC Part No. 112191) included with the dryer.

IMPORTANT: UNDER NO CIRCUMSTANCES SHOULD ANY SAFETY or HEAT CIRCUIT DEVICES EVER BE DISABLED.

THE FOLLOWING PIECES OF TEST EQUIPMENT WILL BE REQUIRED TO TROUBLESHOOT THIS SYSTEM WITH MINIMAL TIME AND EFFORT

MANOMETER

USED TO MEASURE GAS PRESSURE IN INCHES OF WATER COLUMN (W.C.)

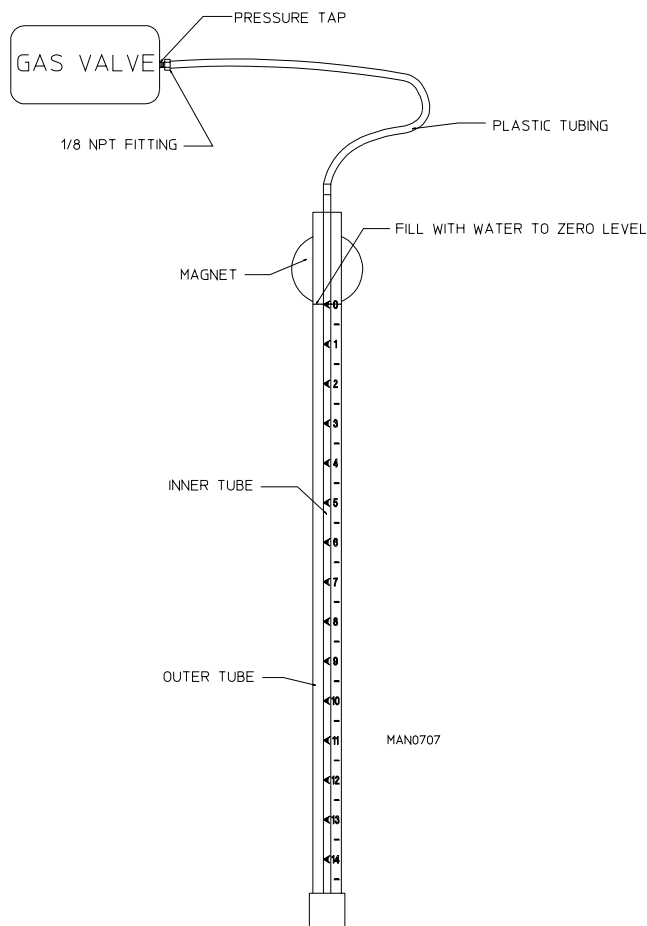

Available From ADC

DSIGNITOR GAP FEELER GUAGE (1/8")

USED FOR CHECKING GAP BETWEEN IGNITOR/FLAME-PROBE ASSEMBLY AND SPARK ELECTRODE

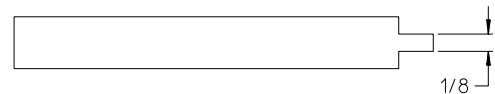

MAN0751

Available From ADC

MULTIMETER/VOLTMETER

FOR MEASURING VOLTAGE

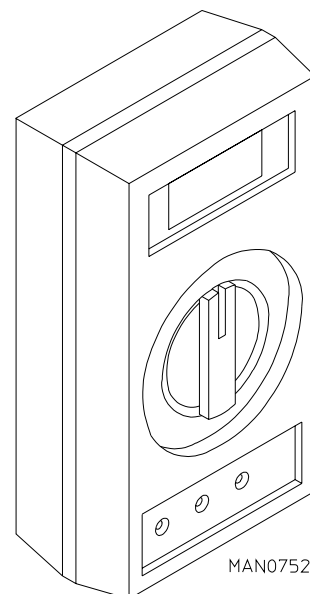

1. Direct Spark Ignition (DSI) Troubleshooting Terms (definitions)

a. DSI (Direct Spark Ignition) MODULE "**RED**" L.E.D. (Light Emitting Diode) INDICATOR LIGHT

This "**red**" L.E.D. (light emitting diode) light is located in the upper right corner of the DSI (Direct Spark Ignition) module (refer to the **top illustration** on **page 30**). This is a *diagnostic indicator* that simplifies the operational and troubleshooting procedures of the DSI system.

b. LOCK-OUT MODE - DSI (Direct Spark Ignition) module "**red**" L.E.D. (light emitting diode) indicator light stays on continuously. This indicates there is a system fault and most likely the fault is the DSI module itself.

c. FLAME-OUT - burner flame shut down by the DSI (Direct Spark Ignition) module due to lack of flame verification. This condition occurs only after ignition is evident but is lost. The DSI system will immediately attempt to relight the burner.

d. RECYCLE - flame has been sensed but lost. Initiate a new sequence (**THERE ARE NO RETRIES**).

2. Troubleshooting and System Basic Diagnosis

a. Preliminary Steps

The following steps **must be** preformed to minimize the time required to isolate cause of fault.

1) DSI (Direct Spark Ignition) module L.E.D. (light emitting diode) indicator light is off (no "**red**" or "**green**" light).

a) Check for voltage (approximately 24 VAC) across the DSI model terminals "TH" and "GND..."

If voltage (approximately 24 VAC) is evident, then, there is a malfunction within the DSI module itself, and it **must be** replaced.

If there is no voltage present, then problem is not the DSI module or the ignition system, the problem elsewhere in the dryer (i.e., dryers' heat circuit [sail switch, hi-limit circuits], etc.).

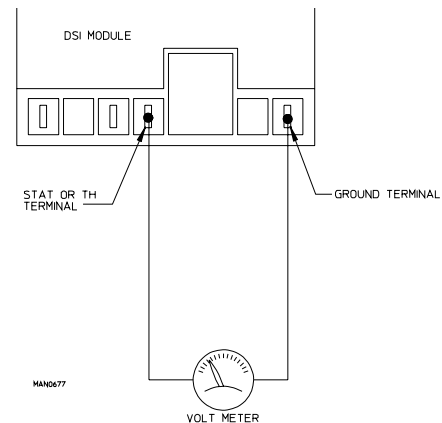

2) DSI (Direct Spark Ignition) module L.E.D. (light emitting diode) indicator lights "**red**" for approximately 1.5 seconds (prepurge). This indicates that **ALL** the controls (including **ALL** the safety circuits) are functioning and power is being supplied to the DSI module.

3) DSI (Direct Spark Ignition) module L.E.D. (light emitting diode) indicator lights "**green**." This indicates a normal heating cycle. This also indicates that the preliminary diagnostics of the module has confirmed that the DSI module is functional.

4) DSI (Direct Spark Ignition) module L.E.D. (light emitting diode) indicator lights "**red**" continuously... LOCK-OUT MODE. This indicates that there is a system fault and most likely the fault is internal to the DSI module. To make sure, open and close the main door. Restart the dryer...if the module LOCKS-OUT ("**red**" L.E.D. indicator light stay on continuously) again, replace the DSI module.

If the dryer repeatedly has DSI (Direct Spark Ignition) module "LOCK-OUT" failures, the cause may be due to high voltage not getting into the DSI module ignitor probe assembly.

- (1) ***Check to insure that the red high voltage wire*** (between the ignitor spark electrode and the DSI [Direct Spark Ignition] module) ***is not wrapped around the sensor probe wire*** (the wire between the DSI module FP terminal and the ignitor and flame-probe assembly). ***If the wires are touching one another, separate and secure in place AWAY FROM ONE ANOTHER.***
- (2) Check to insure that the dryer is properly grounded and that the ground connections (GND) to the DSI (Direct Spark Ignition) module are secure.
- (3) If the problem persists, it is most likely to be in the external components (not the DSI [Direct Spark Ignition] module), or wiring, due to a "FLAME-OUT" ... proceed as follows:

NOTE: Preliminary steps - **DO NOT OMIT** - to minimize the time required to troubleshoot this system.

- (a) Discontinue the electrical service to the dryer.
 - (b) Visually check the DSI (Direct Spark Ignition) module components for visual damage.
 - (c) Check wiring for loose connections, nicks or cracking at the ceramic insulator, or shorting of the sensor to the burner.
 - (d) Inspect the DSI (Direct Spark Ignition) ignitor and flame-probe assembly...
 - ...check electrode for visible cracking at the ceramic insulator or shorting of sensor to burner
 - ...check to insure that the flame sensor rod is positioned over the flame area
 - ...check for carbon deposits on the flame sensor rod
 - ...check to insure that there is a 1/8" gap between the ground rod and the ignitor spark electrode
- b. After performing these inspections and making corrections - if any - restore power to the dryer ... start the dryer and operate through one (1) complete cycle to insure that **ALL** components are functioning properly. If a no heat condition persists refer to the **Troubleshooting Flow Charts** on **page 37**, **page 38**, and **page 39**.
- 1) To effectively use this information or the flow charts, each step **must be** completed in sequence, performing whatever test are suggested. After the completion of each test, the guide will direct the Service Technician to the next logical step in the troubleshoot sequence based on the outcome of the previous check.
 - 2) Components **should be** replaced *only* after each step has been completed and replacements after each step has been completed and replacement is suggested in the flow chart. However, the experienced technician realizes that a loose connection or broken or shorted wire may be at fault where electrical components are concerned... and not necessarily the suspected component itself.

c. Three Visual Checks

- 1) Does the DSI ignitor/flame-probe assembly start sparking?
If not, refer to the **FIRST VISUAL CHECK** on **page 37**.
- 2) Does the main burner ignite?
If not, refer to the **SECOND VISUAL CHECK** on **page 38**.
- 3) Does the main burner remain lit after ignition has been established ("FLAME-OUT")?
If not, refer to the **THIRD VISUAL CHECK** on **page 39**.

d. Troubleshooting Flow Chart - Quick Reference...

First Visual Check

(Does Ignitor Spark?)

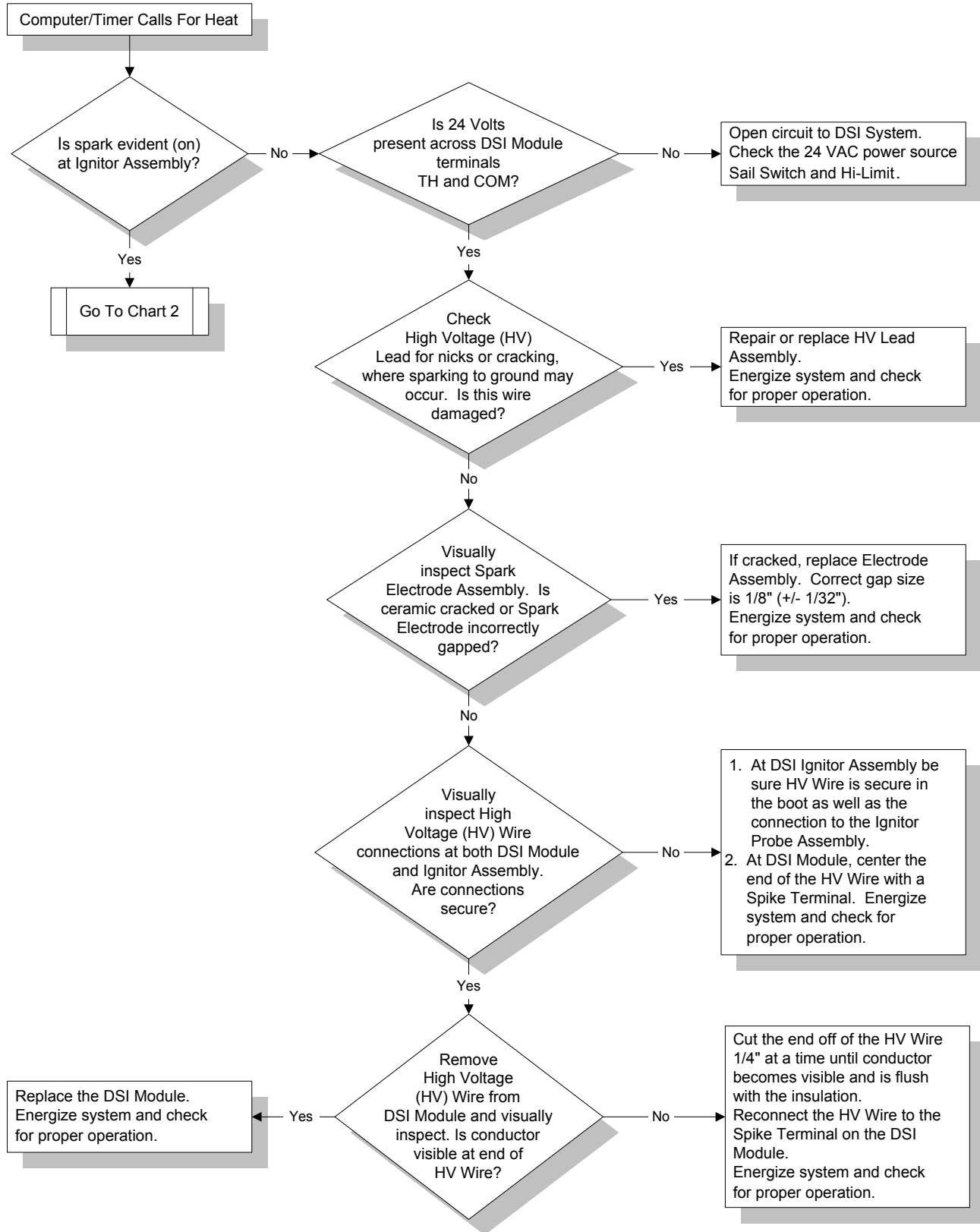

e. Troubleshooting Flow Chart - Quick Reference...

Second Visual Check

(Does Main Burner Ignite?)

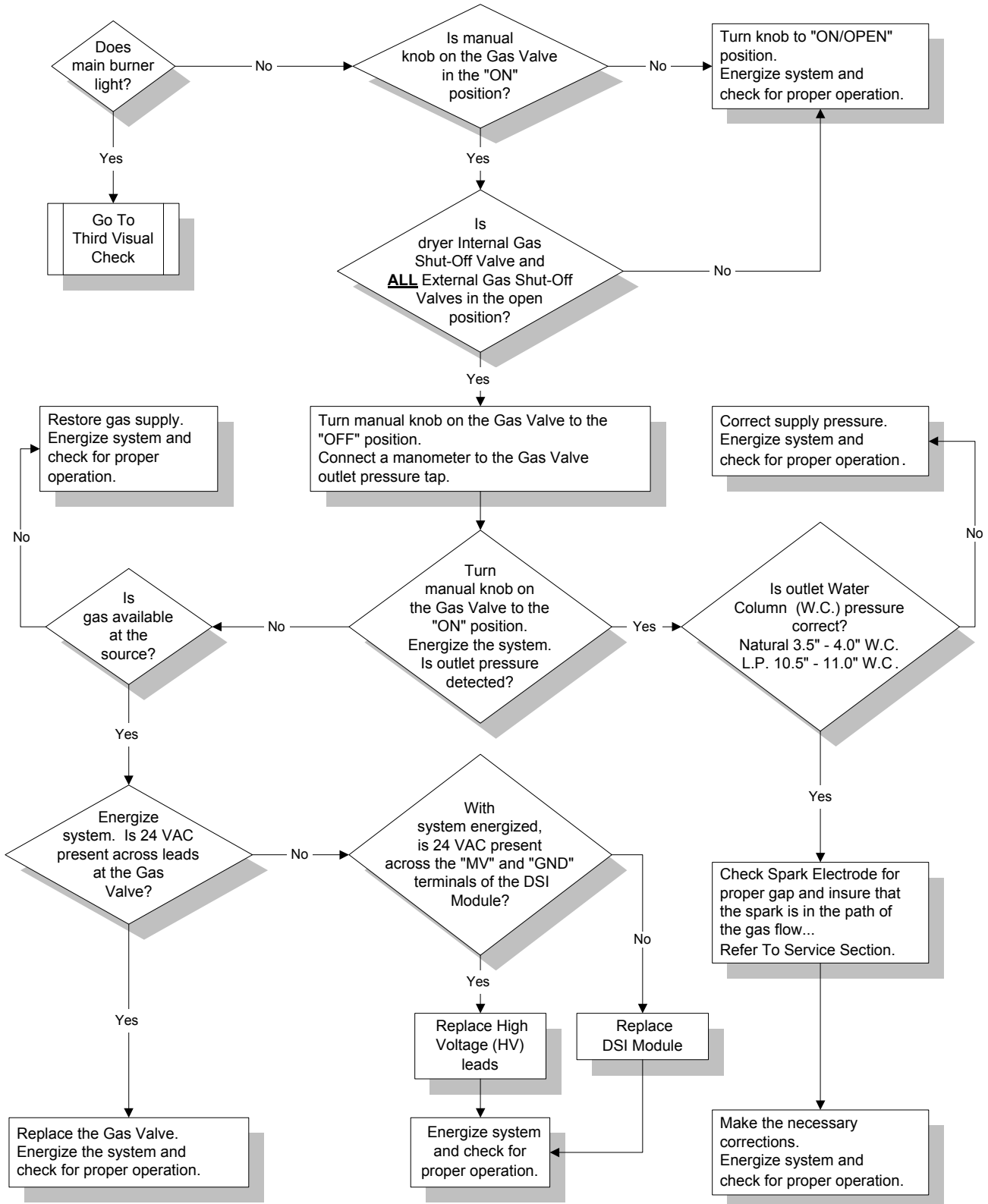

f. Troubleshooting Flow Chart - Quick Reference...

Third Visual Check

(Does Main Burner Ignite?)

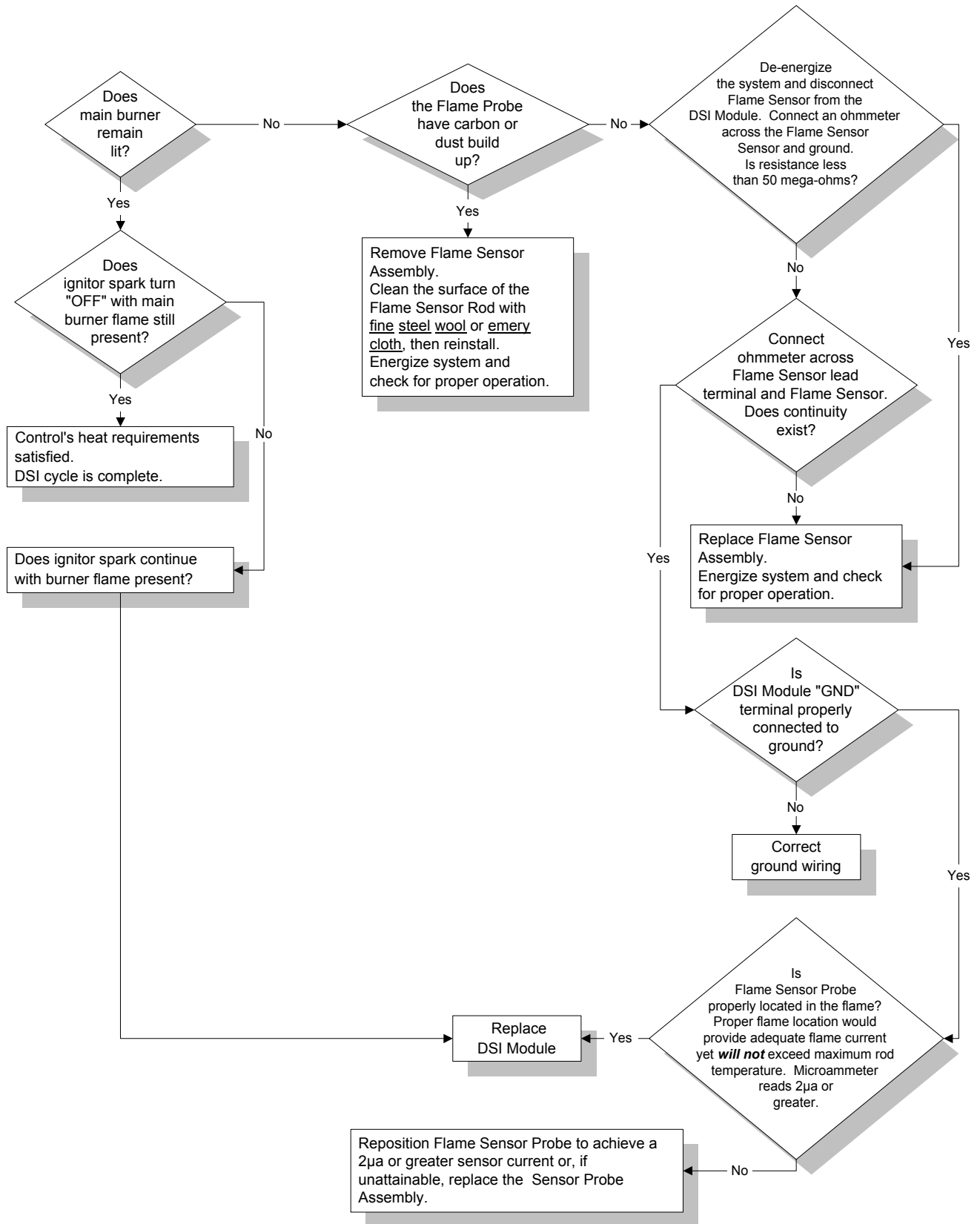

3. Troubleshooting and System Detailed Diagnosis

When the dryer calls for heat, 24 VAC from the step down transformer is applied to the "TH" and "GND" terminals of the DSI (Direct Spark Ignition) module. The DSI module L.E.D. (light emitting diode) indicator will light "**red**" (for up to approximately 1.5-seconds [prepurge]) then the L.E.D. indicator will light "**green**"; the gas valve will be energized, and the spark burst will be evident (on) for approximately 8-seconds at the tip of the electrode flame-probe assembly. Flame **should now be** established and confirmed. If a flame is not sensed and confirmed by the ignitor and flame-probe sensor after the approximate 8-second spark burst, the DSI module will go into the "LOCK-OUT" mode and the L.E.D. will light "**red**" continuously. **THERE ARE NO RETRIES.**

NOTE: If a fault is sensed, the "HEATER FAULT" indicator and the "End of Cycle" indicator will begin to flash at a rate of one (1) flash per second. Both indicators will flash until the "HEATER FAULT" reset push-button has been reset/pressed.

To reset the dryer when a "HEATER FAULT" occurs, press the ("amber") "HEATER FAULT" reset push-button.

If a flame has been established and confirmed and then lost, the DSI (Direct Spark Ignition) module L.E.D. (light emitting diode) indicator will continue to light "**green**" and immediately a spark will be evident (on) for approximately 8-seconds. The flame **should now be** established and confirmed. If a flame is not sensed and confirmed by the ignitor and flame-probe sensor after the approximate 8-second spark burst, the DSI module will go into the "LOCK-OUT" mode and the L.E.D. will light "**red**" continuously. **THERE ARE NO RETRIES.**

NOTE: If a fault is sensed, the "HEATER FAULT" indicator and the "End of Cycle" indicator will begin to flash at a rate of one (1) flash per second. Both indicators will flash until the "HEATER FAULT" reset push-button has been reset/pressed.

To reset the dryer when a "HEATER FAULT" occurs, press the ("amber") "HEATER FAULT" reset push-button.

a. System Diagnosis

1) Gas Pressure

A gas pressure test **should be** taken at the gas valve pressure tap provided on every gas valve to assure that the water column (W.C.) pressure is correct and consistent.

There are two (2) types of devices commonly used to measure water column (W.C.) pressure. They are the spring and mechanical type gauge and the water column test gauge (manometers). The use of the spring and mechanical type gauges **IS NOT RECOMMENDED** because they **are not** always accurate. The preferred type of gauge is the manometer because it is a simple device to use and is highly accurate. A manometer is simply a glass or transparent plastic tube with a scale graduated in inches. When it is filled with water and pressure is applied, the water in the inner tube lowers, showing the exact water column (in W.C.) pressure in inches.

WARNING: Test ALL connections for leaks by brushing on a soapy water solution. **NEVER TEST FOR LEAKS WITH A FLAME!!!**

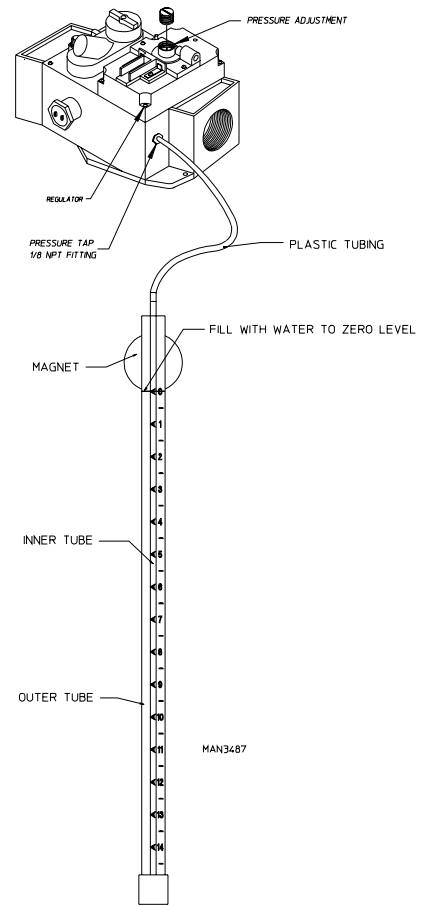

- a) Connect the water column test gauge (manometer) to the gas valve pressure tap (1/8" N.P.T.). Refer to the illustration above.
- b) Start the dryer... with the burner on, the correct water column pressure (W.C.) reading in inches **should be:**

Natural Gas 3.5 - 4 inches W.C.
 L.P. (liquid propane) Gas 10.5 - 11 inches W.C.

When a gas dryer is first started (during initial time of installation or start-up), it has a tendency not to ignite on the first ignition attempt. This is due to the fact that the gas supply piping is filled with air, so it may take a few minutes for the air to be purged from the supply lines. During this purge period there may be insufficient gas pressure for ignition, which might cause the DSI module to go into the "LOCK-OUT" mode (the L.E.D. [light emitting diode] will LIGHT "RED" CONTINUOUSLY).

NOTE: "HEATER FAULT" will occur during the initial set-up of the dryer, indicating that the burners **are not** lighting due to air in the gas line.

To reset the dryer when a "HEATER FAULT" occurs, press the ("amber") "HEATER FAULT" reset push-button.

- c) If gas pressure is low, unscrew slotted regulator cover on top of the gas valve and turn regulator (pressure) adjustment screw (located underneath the cover) clockwise (CW) to increase the pressure.

2) Ignitor and Flame-Probe Assembly

The ignitor and flame-probe assembly consists of a ceramic insulated ignitor electrode, a ground rod, and a ceramic insulated flame-probe electrode. ***The GAP between the ignitor electrode and the ground rod is set, and must be maintained at 1/8" +/- 1/32" (.1250 +/- .03121).*** When the DSI (Direct Spark Ignition) module provides the high synchronous spark (14,000 volts) through the high voltage (HV) lead, a spark is produced over the GAP. When this spark is produced, the gas valve is opened. Upon ignition, the flame probe electrode (of the ignitor and flame-probe assembly) has high voltage provided to it that supplies a small current to ground through the flame. Once the current is sensed, it initializes the DSI module to sustain the gas flow (from the gas valve).

IMPORTANT: THE GAP SETTING ON THE IGNITOR AND FLAME-PROBE ASSEMBLY IS CRITICAL.

a) DSI Ignitor and Flame-Probe Assembly Adjustments

- (1) **The GAP on the ignitor and flame-probe assembly must be set, and held at 1/8" +/- 1/32" (.1250 +/- .03121).** If this GAP is not maintained (if the GAP is either too large or too small), the DSI (Direct Spark Ignition) module will indicate a system malfunction and go into the "LOCK-OUT" mode (the L.E.D. [light emitting diode] will LIGHT "RED" CONTINUOUSLY).

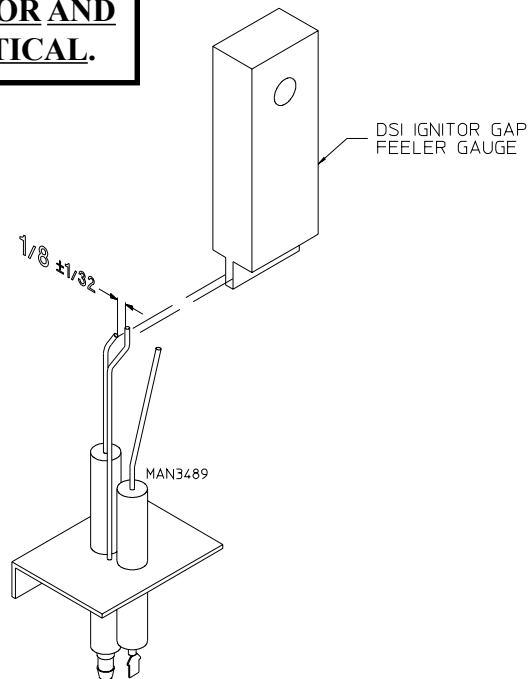

- (a) To check and/or set the 1/8" GAP, use a DSI Gap Feeler Gauge or similar device to determine GAP size. **DO NOT USE FEELER TO SET THE GAP**, use it only to determine the size of the gap. If an adjustment is necessary, bend the ground rod to achieve the correct GAP, then recheck the 1/8" GAP with a feeler gauge.
- (b) The ALIGNMENT of the ignitor and flame-probe assembly in relation to the GAP on the ignitor electrode and ground rod **must be** maintained in as vertical (straight line) a position as possible (refer to the **illustration on page 43**) otherwise the DSI (Direct Spark Ignition) module will indicate a system malfunction and go into the "LOCK-OUT" mode (the L.E.D. [light emitting diode] indicator will LIGHT "RED" CONTINUOUSLY).
- (c) The POSITIONING of the ignitor and flame-probe assembly is **extremely important** because it provides the necessary feedback information to the DSI (Direct Spark Ignition) module. The flame probe electrode **must be** POSITIONED 1/4" minimum into the flame path (refer to the **illustration on page 43**) and **must be** POSITIONED 1-inch maximum from the burner tube (refer to the **illustration on page 43**) otherwise the DSI module will indicate a system malfunction and go into the "LOCK-OUT" mode (the L.E.D. indicator will LIGHT "RED" CONTINUOUSLY).

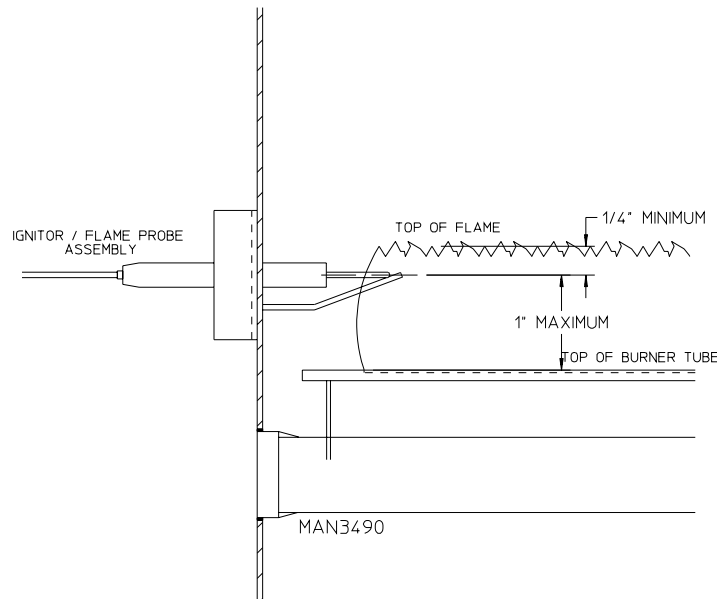

NOTE: To reset the dryer when a "HEATER FAULT" occurs, press the ("amber") "HEATER FAULT" reset push-button.

3) Air Turbulence

If there is sail switch flutter due to air turbulence, or improper impellor (fan/blower) rotation, or a restriction in the exhaust duct work, the DSI (Direct Spark Ignition) module will cycle erratically. This in turn might cause the DSI module to "LOCK-OUT" (where the L.E.D. [light emitting diode] indicator will LIGHT **"RED"** CONTINUOUSLY).

- a) If air turbulence causes the flame to move away from the flame probe electrode (of the ignitor/flame-probe assembly), or if the flame goes out completely during the heat (flame) cycle, the DSI (Direct Spark Ignition) module will attempt to reestablish a flame by going into a re-ignition cycle.

4) Direct Spark Ignition (DSI) Module

If there is some sort of *operational interference* in the DSI system, the DSI (Direct Spark Ignition) module (acting as the "controller" for the system) will go into a "LOCK-OUT" mode (where the L.E.D. [light emitting diode] indicator will LIGHT **"RED"** CONTINUOUSLY).

- a) *Operational interference* is any adverse condition (whether internal or external) to the system. (Electrical noise is considered external *noise interference* because it can cause the DSI [Direct Spark Ignition] module to cycle erratically.)

NOTE: To reset the dryer when a "HEATER FAULT" occurs, press the ("amber") "HEATER FAULT" reset push-button.

If the GAP, the ALIGNMENT, and the POSITION of the ignitor and flame-probe assembly are correct, if the gas flow and pressure is constant and consistent; if there is no adverse air turbulence; and if the DSI (Direct Spark Ignition) module remains in the "LOCK-OUT" mode (where the L.E.D. [light emitting diode] indicator will LIGHT **"RED"** CONTINUOUSLY) then, there is a malfunction with the DSI module itself, and it **must be** replaced.

5) Wiring

If the DSI (Direct Spark Ignition) module is in the "LOCK-OUT" mode (where the L.E.D. [light emitting diode] indicator will LIGHT "RED" CONTINUOUSLY), and the mechanical components have been checked (i.e., the ignitor/flame-probe assembly, the gas valve, etc.), then, there may be a problem somewhere in the DSI system wiring.

- a) Check **ALL** the wiring within the Direct Spark Ignition (DSI) system, especially the ground connections at the DSI module and the ignitor and flame-probe assembly.

NOTE: Check for any possible damage to the ceramic insulators on the ignitor electrode and the flame-probe electrode of the ignitor and flame-probe assembly.

- b) Make sure the flame-probe electrode of the ignitor and flame-probe assembly is positioned no more than one (1) inch maximum from the burner tube.

CAUTION: DO NOT LET THE IGNITOR AND FLAME-PROBE ASSEMBLY TOUCH THE BURNER TUBES; OTHERWISE THE ENTIRE ASSEMBLY WILL SHORT OUT.

6) Direct Spark Ignition (DSI) 24 VAC Transformer

The DSI transformer is designed to step down the operating voltage of the dryer to 24 VAC. This operates the DSI module. This transformer, like **ALL** transformers is two (2) sided;

- a) Primary Side...

This is the incoming voltage side - 208 VAC, 230/240 VAC, 380 VAC, 416 VAC, 480 VAC - of the transformer.

- b) Secondary Side...

This is the step down side - 24 VAC - of the transformer.
(If the dryer is above 240 VAC a secondary voltage of 240 VAC will also be present.)

WARNING: **208 VAC and 230/240 VAC ARE NOT THE SAME.** **ALL** voltage connections *should be* checked and confirmed according to the foil data label provided with the individual dryer. Any damage done to dryer components due to improper voltage connections will automatically VOID THE WARRANTY.

IMPORTANT: The ADC Service Department *must be* contacted prior to any wiring change or conversion because, depending on the change or conversion required, some parts may have to be added, deleted, or changed. When contacting the ADC Service Department, they *must be* given the correct **model number(s)** and **serial number(s)** for the dryer(s).

NOTE: Any wiring changes or conversions *should be* accomplished by a QUALIFIED ELECTRICAL TECHNICIAN.

C. NATURAL GAS and L.P. (Liquid Propane) GAS CONVERSION INSTRUCTIONS

IMPORTANT: CONVERSION ***MUST BE*** PERFORMED BY COMPETENT TECHNICIANS IN ACCORDANCE WITH LOCAL and STATE CODES.

NOTE: Converting the dryer to L.P. Gas disables the internal regulator of the gas valve, therefore, an external regulator ***must be*** provided at the source of the L.P. gas supply (L.P. tank) on the dryer. The water column (W.C.) gas pressure ***must be*** regulated to between 10.5 -inches and 11-inches for safe and efficient dryer operation. Low, inconsistent, or too high a gas pressure will result in improper operation of the dryers' heat and safety circuits. **POOR EFFICIENCY CAN CREATE A POTENTIAL SAFETY HAZARD.**

1. Discontinue electrical service to the dryer.
2. Close **ALL** gas shut-off valves in the dryers' gas supply line.

Turn the gas cock dial to the off position on the gas valve.

3. Disconnect the gas valve wiring.

Be sure to identify the correct location of each wire for correct reinstallation.

4. Disconnect union connection in the gas supply line.

IMPORTANT: Pipe joint compounds that resist the action of natural gas and L.P. gas ***must be*** used.

5. Loosen and remove the screws from the brackets holding the gas valve/manifold assembly to the burner box.
6. Remove the gas valve and manifold assembly from the dryer.
7. Unscrew the main burner orifices and replace them with the L.P. orifices provided.

NOTE: Use extreme care when handling (removing or replacing) orifices. **THESE ORIFICES ARE MADE OF BRASS and CAN BE EASILY DAMAGED.**

8. Remove the two (2) screws on the gas valve regulator.

Remove the regulator and the gasket.

9. Install the new gasket and L.P. regulator.

Replace the two (2) screws.

NOTE: USE **ONLY** NEW PARTS PROVIDED.

10. Place the L.P. conversion labels on the gas valve.

11. Reverse the procedure for reinstalling the gas valve/manifold assembly to the dryer.
12. Open **ALL** gas shut-off valves (closed in **Step #2**).
13. Reestablish electrical service to the dryer.
 - a. Test **ALL** connections for leaks.

IMPORTANT: Test **ALL** connections for leaks by brushing on a soapy water solution (liquid detergent works well).

WARNING: NEVER TEST FOR LEAKS WITH A FLAME!!!

14. Operate the dryer through one (1) complete drying cycle to insure proper operation.

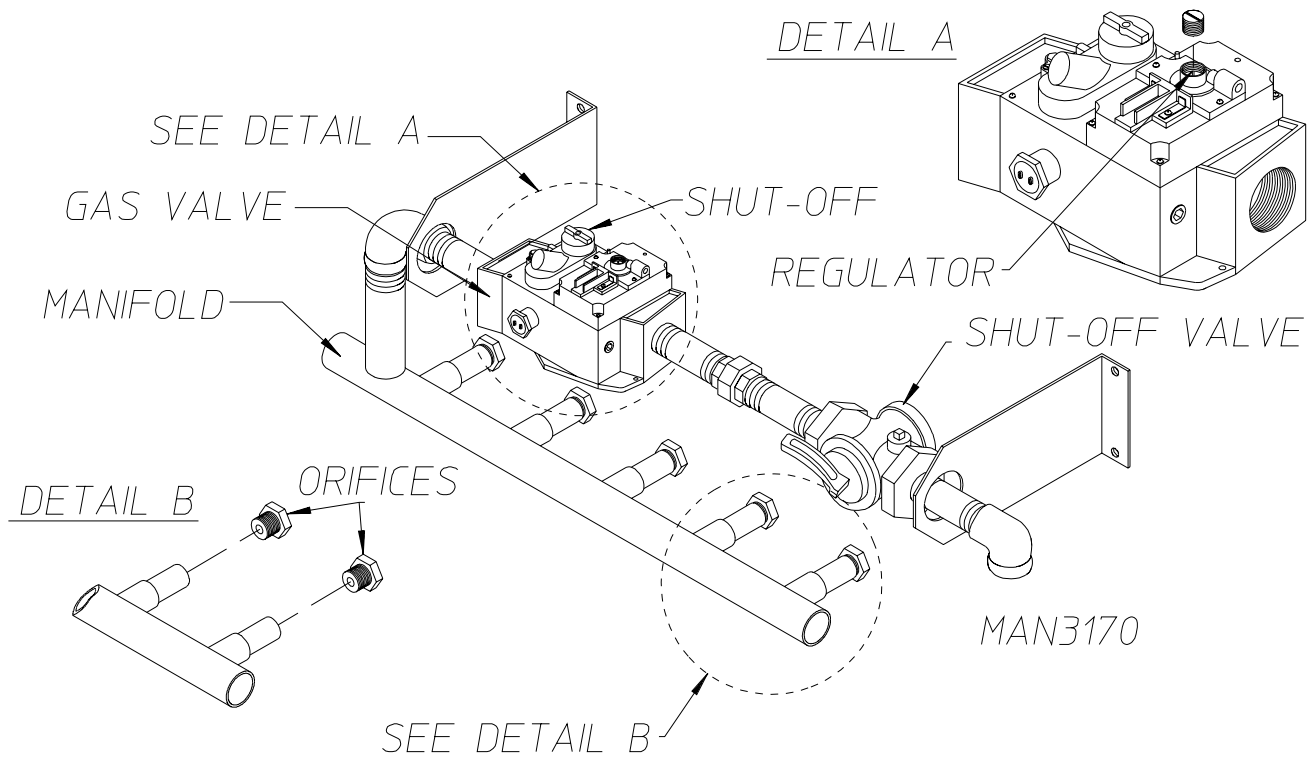

D. STEAM COIL SYSTEM OPERATION

General Overview

The dryers' steam coil is constantly charged thereby eliminating repeated expansion and contraction and also provide instant heating to start the drying process. The steam damper, located on top of the steam coil, is the only temperature controlling device in this system. When the steam damper is open, ambient air is drawn through the coil providing heat to the dryer. When the steam damper is closed, ambient air is drawn directly into the tumbler, bypassing the coil, allowing a rapid cool down.

NOTE: With the dryer off or no air supply to the damper piston, the damper is in the Cool Down mode... the coil is constantly charged.

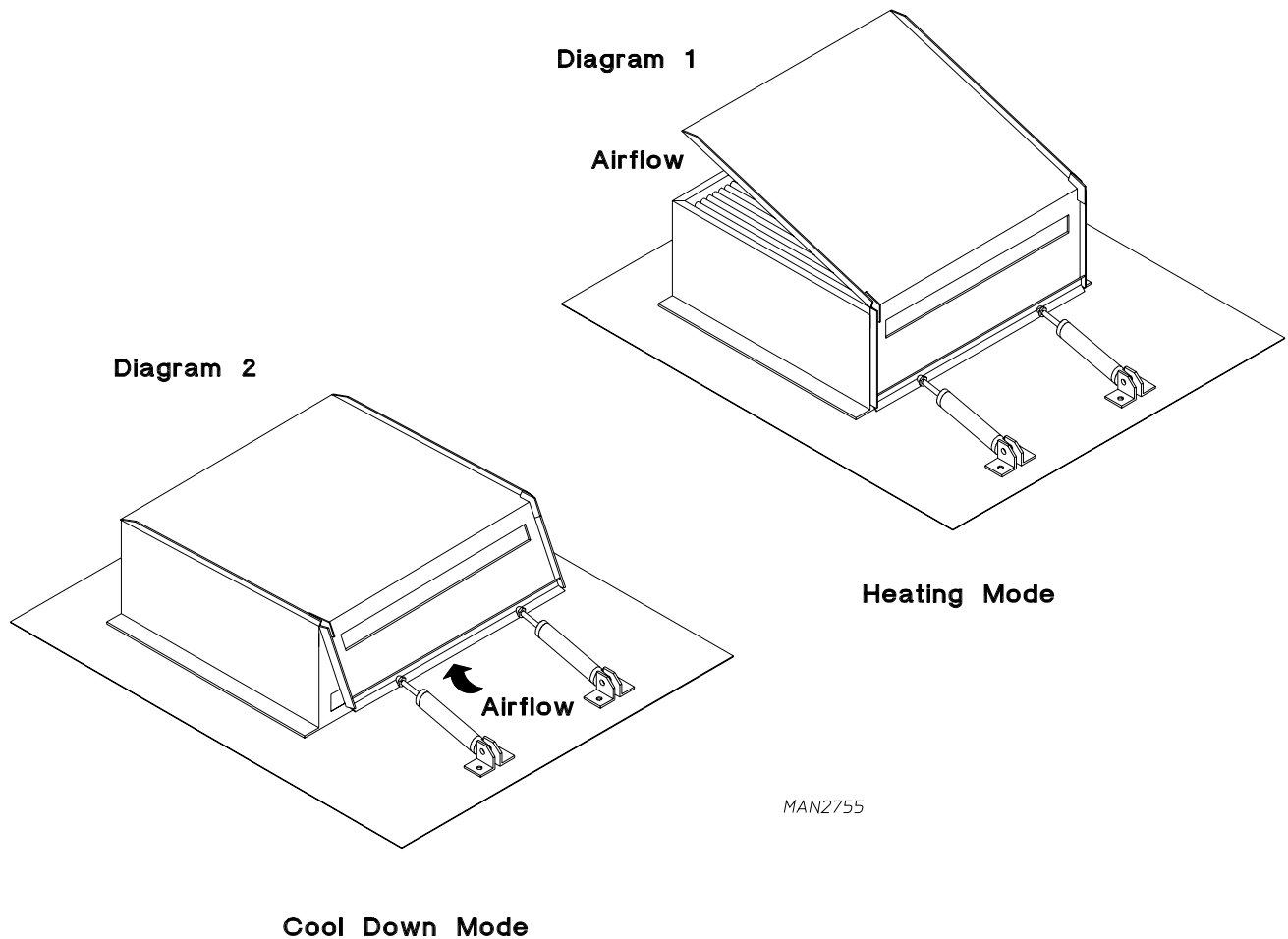

1. Steam Coil PH Level

The normal PH level for copper type steam coils **must be** maintained between a value of 8.5 to 9.5. For steel type steam coils the PH level **must be** maintained between a value of 9.5 to 10.5. These limits are set to limit the acid attack of the steam coils.

IMPORTANT: Coil failure due to improper PH level will VOID THE WARRANTY.

2. Steam Damper Actuator System

The steam damper actuator system consists of a hinged damper plate, pneumatic piston, and a 24 volt solenoid valve with a needle valve to control the speed of the piston actuation.

On a call for heat, a 24 volt signal is applied to the 3-way/2-position solenoid valve. This signal switches the valve so that compressed air is sent to the piston. The piston rod extends, pushing the hinged steam damper plate to the open position. This allows room air to be drawn through the hot steam coil and then through the basket (tumbler).

When the temperature set point has been reached, the 24 volt signal is removed from the solenoid valve, so that the solenoid valve blocks the air supply to the piston, and air in the piston is bled to the atmosphere. The spring in the piston now retracts the piston rod, closing the steam damper. The steam damper plate now covers the steam coil and allows room air to bypass the coil before entering the basket (tumbler) for a rapid cool down.

The steam damper plate should open and close slowly and smoothly. The speed can be modulated by adjusting the needle valve knob. Turning the knob clockwise (CW) restricts the compressed air flow and slows the steam damper movement. Counterclockwise (CCW) adjustment speeds up the steam damper motion. Upon completion of the adjustment, tighten the needle valve's locking nut.

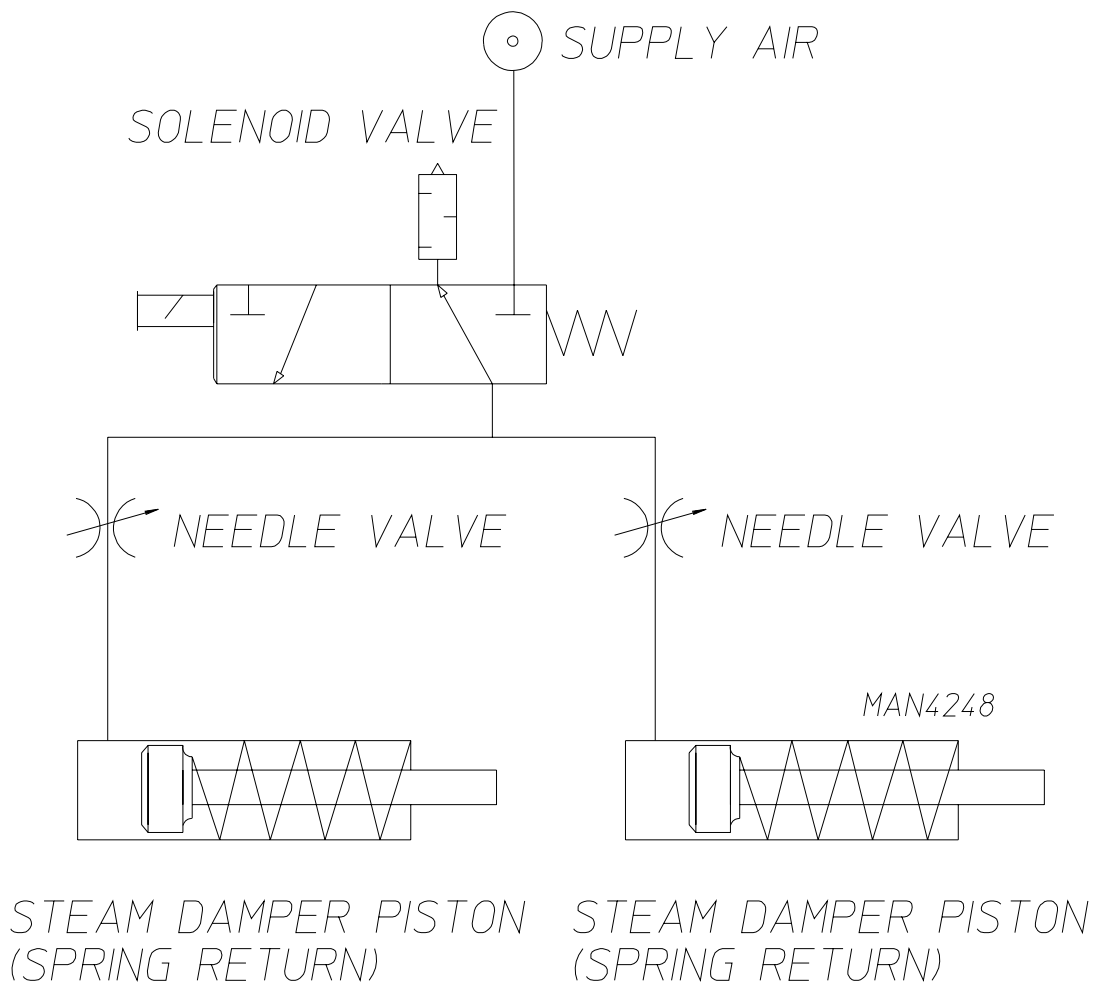

3. Steam Damper Actuator System Service and Replacement

a. Steam Damper Cylinder or Piston Replacement

- 1) Disconnect compressed air supply from the dryer.
- 2) Disconnect tubing from the piston.
- 3) Remove the spring clip from clevis pin then slide out the clevis pin.
- 4) Remove the steam damper cylinder (piston).
- 5) To install new steam damper cylinder (piston), reverse above procedure.

b. Steam Solenoid Valve Replacement

- 1) Disconnect compressed air supply from the dryer.
- 2) Discontinue electrical service to the dryer.
- 3) Disconnect wires in junction box.
- 4) Remove tubing from the inlet side of the valve.
- 5) Remove the valve from the bracket.
- 6) Unscrew the valve from the outlet side.
- 7) To install new steam solenoid valve, reverse above procedure.

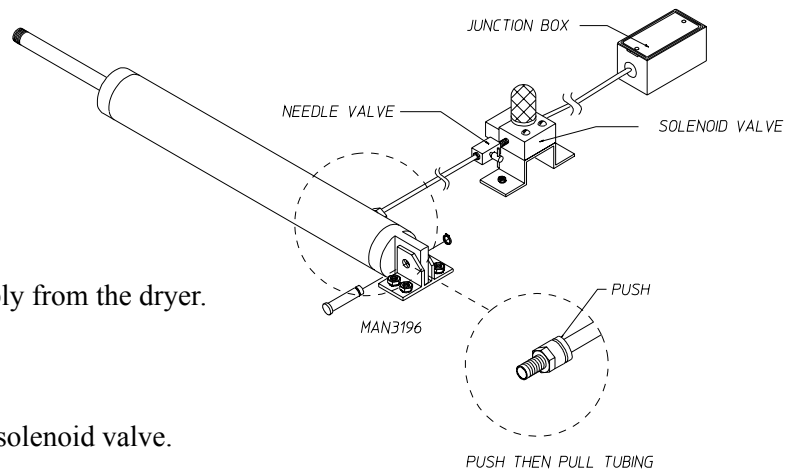

c. Needle Valve Replacement

- 1) Disconnect compressed air supply from the dryer.
- 2) Remove tubing from the valve.
- 3) Unscrew needle valve from the solenoid valve.
- 4) To install new needle valve, reverse above procedure.

d. Steam Coil Replacement

- 1) Discontinue electrical service to the dryer.
- 2) Disconnect compressed air supply from the dryer.
- 3) Shut off **ALL** steam supply lines and steam return valves that feed the steam coil.
- 4) Wait a sufficient amount of time until **ALL** of the steam lines and the steam coil is cool.
- 5) Open 1/2" plug on the return line to bleed off any residual steam pressure.

CAUTION: MAKE CERTAIN THAT THE ENTIRE STEAM SYSTEM (coil, lines, valves, etc.) ARE COOLED TO AVOID HOT STEAM ESCAPING and TO AVOID PERSONAL INJURY.

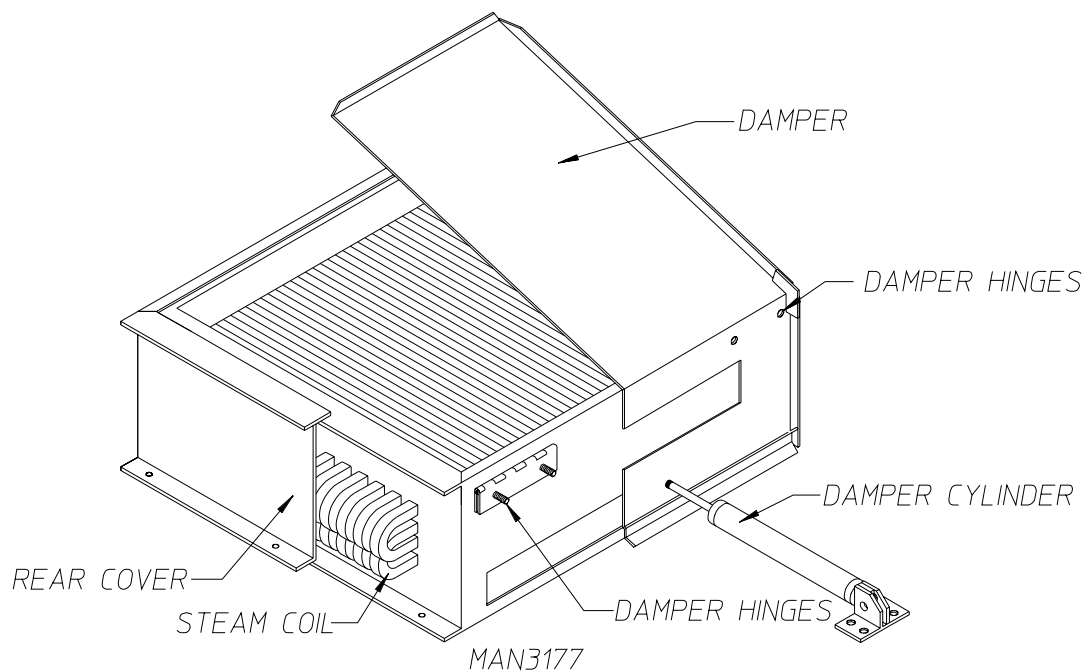

CUT AWAY VIEW OF STEAM COIL ASSEMBLY

- 6) Remove steam coil damper cylinder (piston).
- 7) Remove the steam coil damper by unbolting from its hinges.
- 8) Disconnect steam supply lines and steam return lines at the unions.
- 9) Remove the remaining piping from the steam coil
- 10) Remove **ALL** of the panels surrounding the steam coil.
- 11) Unbolt the steam coil and remove.

WARNING: THE STEAM COIL IS HEAVY. A crane may be needed to remove (and install) the steam coil.

- 12) Remove the steam coil damper hinges from the old coil and install them on the new steam coil.
- 13) Hoist the new steam coil into place and bolt down.
- 14) Replace **ALL** of the panels removed in **Step #10**.
- 15) Reinstall **ALL** of the piping removed from the old steam coil in **Step #9**.

NOTE: Thread sealant certified for steam piping **must be** applied to the threads.

- 16) Reconnect **ALL** of the piping (supply lines and return lines) disconnected in **Step #8**.
- 17) Reinstall steam damper cylinder (piston) removed in **Step #6**.
- 18) Reestablish electrical service to the dryer.
- 19) Close the 1/2" plug which was opened in **Step #5**.

WARNING: THE 1/2" PLUG MUST BE CLOSED BEFORE ATTEMPTING TO APPLY ANY STEAM PRESSURE.

- 20) *Slowly* open the return line then *slowly* open the supply line.

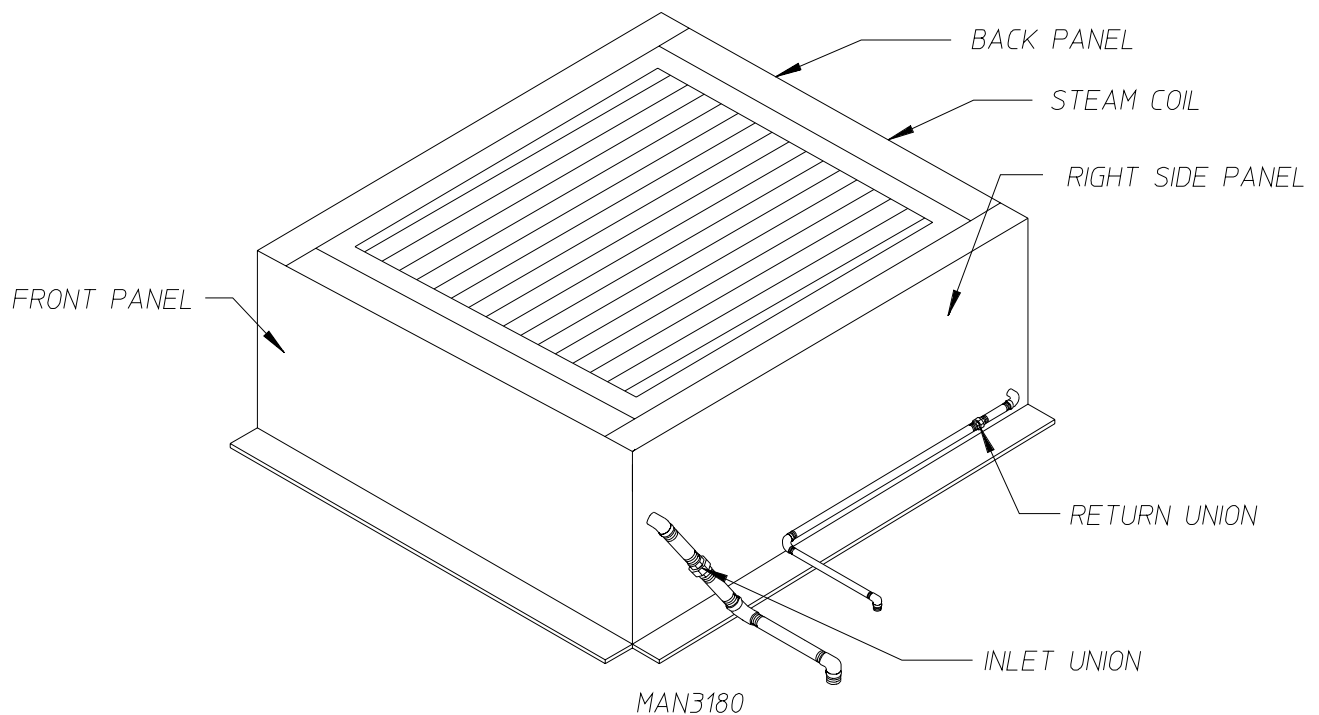

VIEW OF STEAM COIL w/ DAMPER REMOVED

E. SPRINKLER SYSTEM DESCRIPTION

The sprinkler system is monitored by a microprocessor based temperature controller as a designated "FAIL-SAFE." The microprocessor circuit **must have** power in order to engage main power to the dryer. When cycling the dryer, if the temperature at the Resistive Temperature Device (RTD) reaches 575° F, one (1) set of contact in the controller will open, disabling the power (electric supply) to the dryer. Another set of contacts will close, sounding the alarm and turning on the sprinkler.

NOTE: The sprinkler as well as the alarm will remain on until the "amber" colored sprinkler reset button is pressed and the temperature in the tumbler (basket) falls below 575° F (301.6° C).

1. Description Of Components

a) Resistive Temperature Device (RTD)

The RTD is located above the tumbler (basket). The probe is a 100 Ω (ohm) platinum RTD. As the temperature increases or decreases the resistance value corresponds to the ambient temperature (i.e., 100 Ω = 32° F / 0° C ... 109 Ω = 75° F / 24° C).

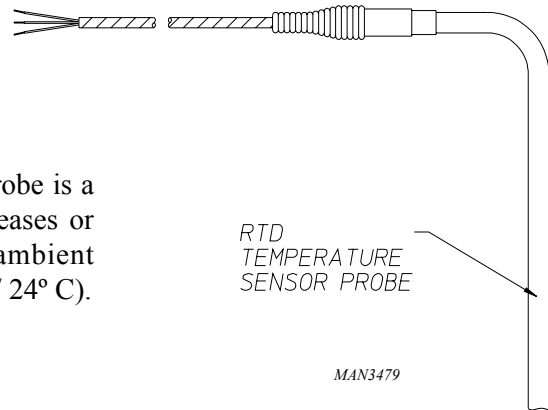

b) Sprinkler Valve

The sprinkler valve is a 2-way , air piloted, normally closed valve. With pilot air pressure applied, the valve opens allowing water to flow.

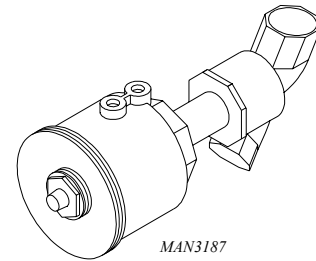

c) Sprinkler Solenoid Valve

The sprinkler solenoid valve is a 3-way/2-position solenoid valve that is used to supply pilot air to the sprinkler valve.

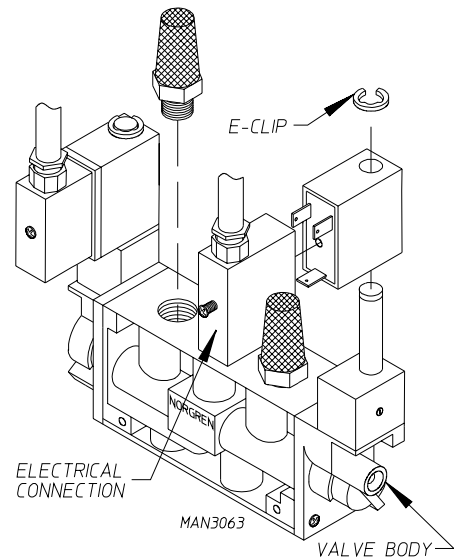

d) Sprinkler Digital Temperature Controller

The sprinkler digital temperature controller is a programmable microprocessor used to monitor temperatures via a Resistive Temperature Device (RTD).

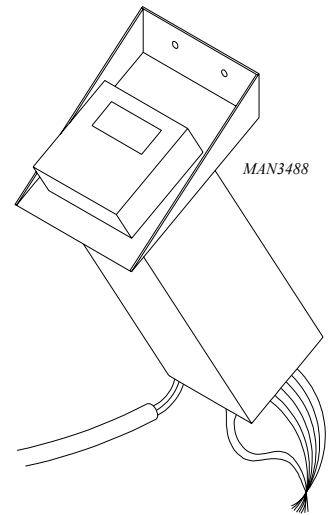

NOTE: Operating parameters are preset at the factory and *should not* require any adjustment.

2. Sprinkler System Operation

NOTE: Refer to the ladder diagram provided with the dryer for specific relay logic.

Master Relay -The coil in this relay **must be** energized in order to close the contacts needed to supply power to the dryers control system.

Relay 1 - The coil in this relay energizes if the set-point is reached closing Contact 1 and Contact 2. Contact 1 latches Relay 1 on. Contact 2 closes, turning on the sprinkler, the horn, and the reset button light. Relay 1 will remain energized until the reset button is pushed.

Relay 2 - The coil in this relay energizes if the set-point is reached closing Contact 3, de-energizing the Master Relay, and shutting power off to the dryer. Relay 2 will remain energized until the reset button is pushed.

NOTE: The Sprinkler System will remain on until the tumbler (basket) temperature falls below the set-point, and the reset button is manually activated.

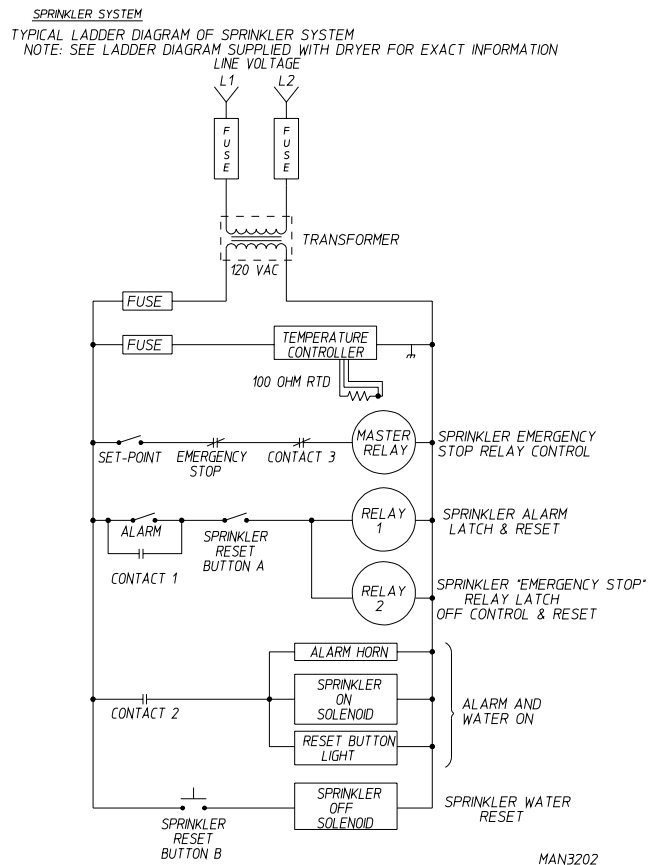

3. Sprinkler System Component Replacement

a. Resistive Temperature Device (RTD) Replacement

- 1) Turn the water supply to the dryer off.
- 2) Discontinue electrical service to the dryer.
- 3) Remove the 1/4" compression fitting.
- 4) Remove the two (2) screws from the junction box cover.
- 5) Remove the wires of the RTD (Resistive Temperature Device) from the terminal strip.

NOTE: Identify the wires removed for proper reinstallation.

- 6) Loosen the cord grip cap.
- 7) Remove Resistive Temperature Device (RTD).
- 8) To install new RTD (Resistive Temperature Device), reverse above procedure..

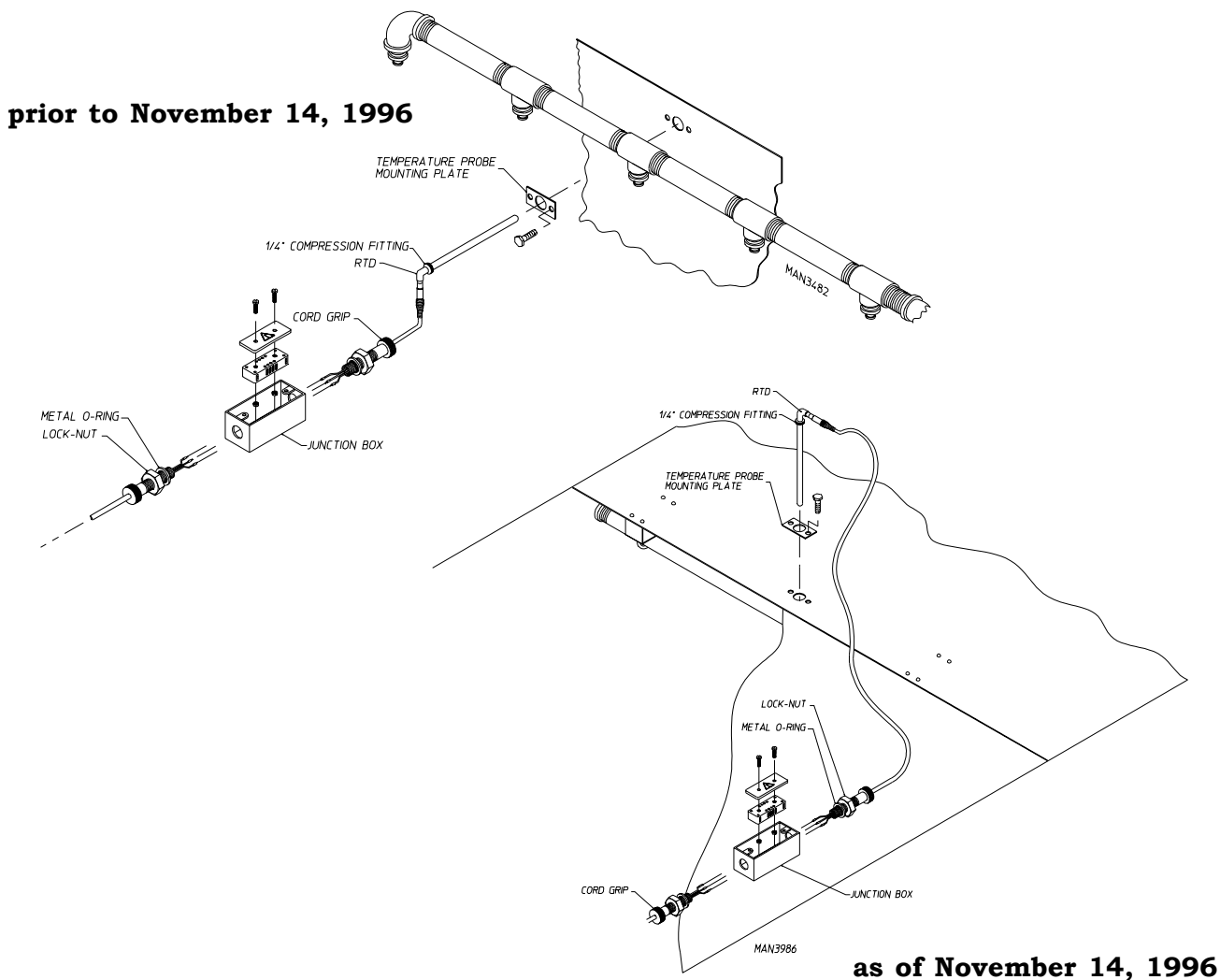

b. Sprinkler Valve Replacement

- 1) Turn the water supply to the dryer off.
- 2) Discontinue electrical service to the dryer.
- 3) Disconnect compressed air supply from the dryer.
- 4) Loosen and remove the hose clamp.
- 5) Remove any residual water to the valve.
- 6) Remove 1/4" air tubing going to the valve.
- 7) Remove the two (2) U-bolts holding the sprinkler valve assembly.
- 8) Unscrew the sprinkler valve from the tubing.
- 9) To install new sprinkler valve, reverse above procedure.

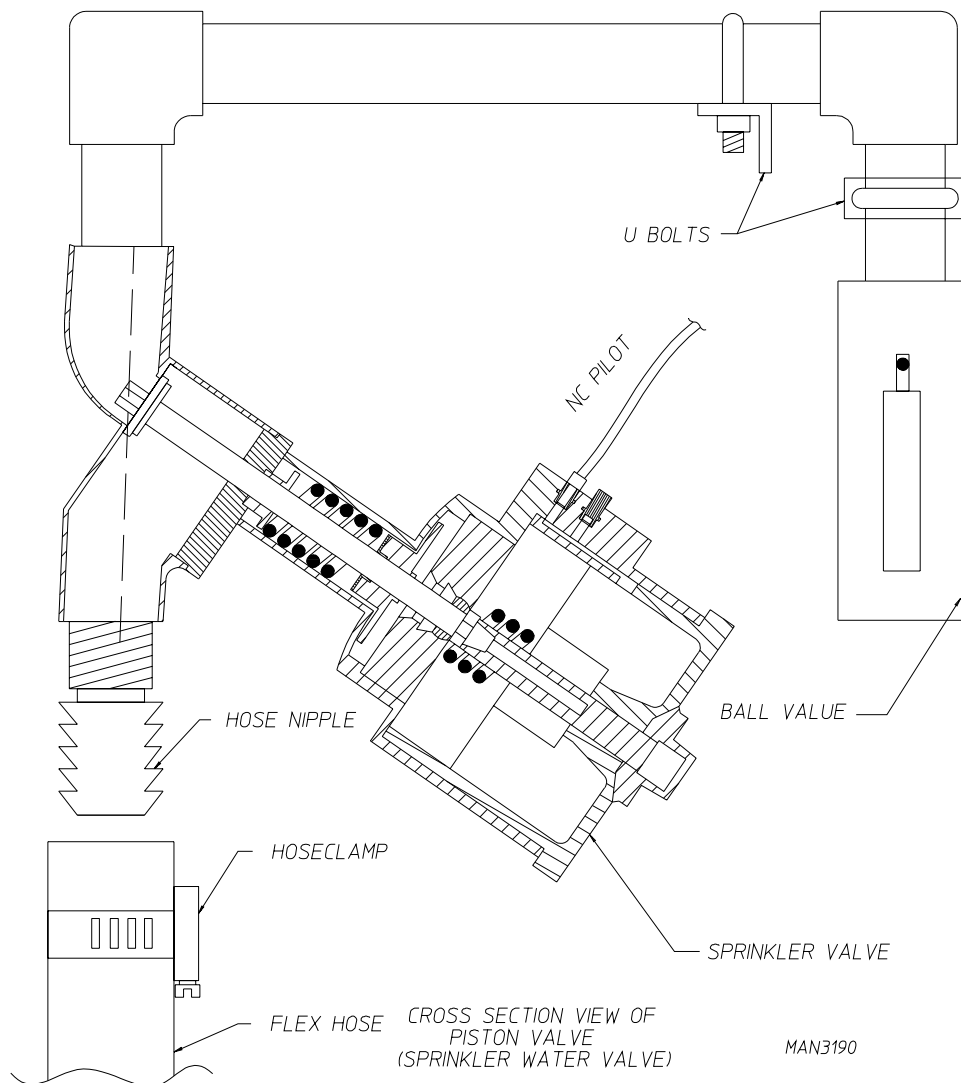

c. 3 HP Control Relay Replacement

WARNING: THE SPRINKLER CIRCUIT HAS A SEPARATE POWER SUPPLY (then the power supply for the dryer). **DISCONNECT and LOCK-OUT BOTH POWER SUPPLIES BEFORE SERVICING THE DRYER.**

- 1) Mark and identify the wires that will be removed for proper reinstallation.
- 2) Press down on the control relay and lift the bottom out and up to remove from the din rail.
- 3) Remove the wires.
- 4) Replace the bad control relay.
- 5) Replace the wires removed from *Step #3*.

NOTE: Make sure wires are properly reinstalled using identifying markings from *Step #1*.

- 6) Mount the top of the control relay to the top of the din rail, then press down and snap the bottom into the rail.

Set the overload to the setting specified on the dryer blueprints.

- 7) Inspect the work performed before reestablishing electrical service to the dryer.
- 8) Reestablish electrical service to the dryer.

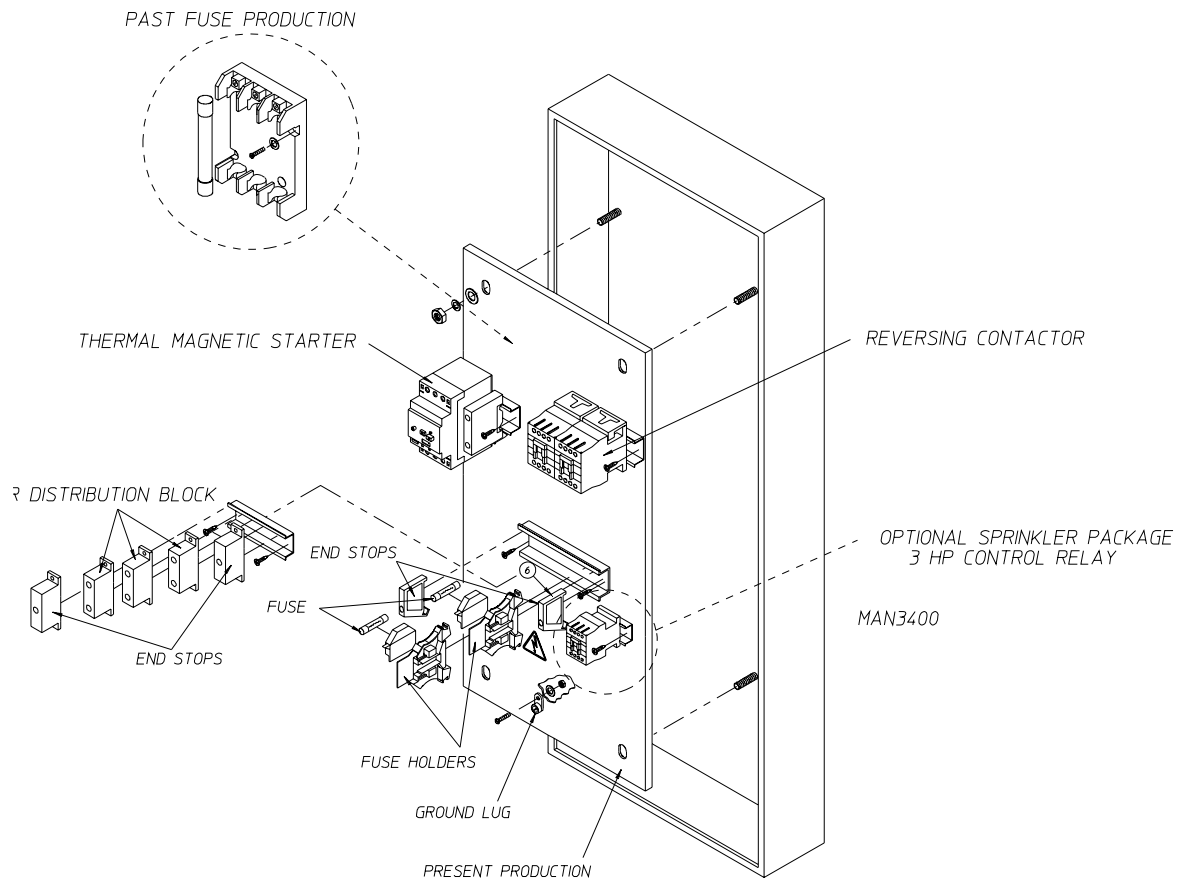

SPRINKLER SYSTEM PNEUMATIC DIAGRAM

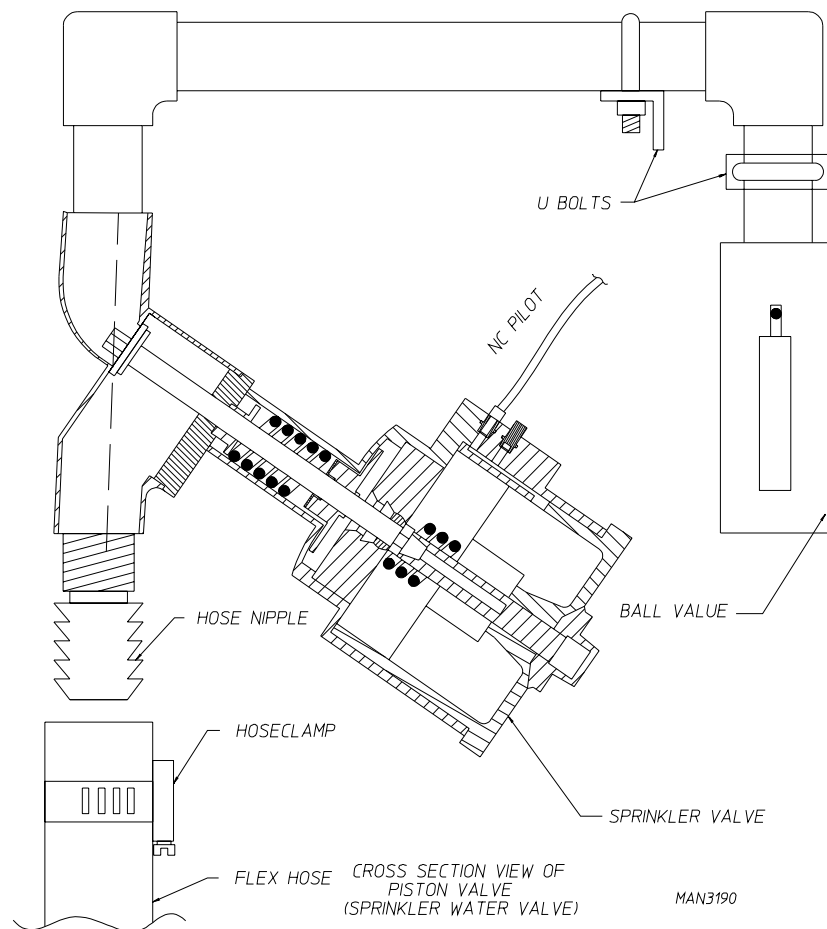
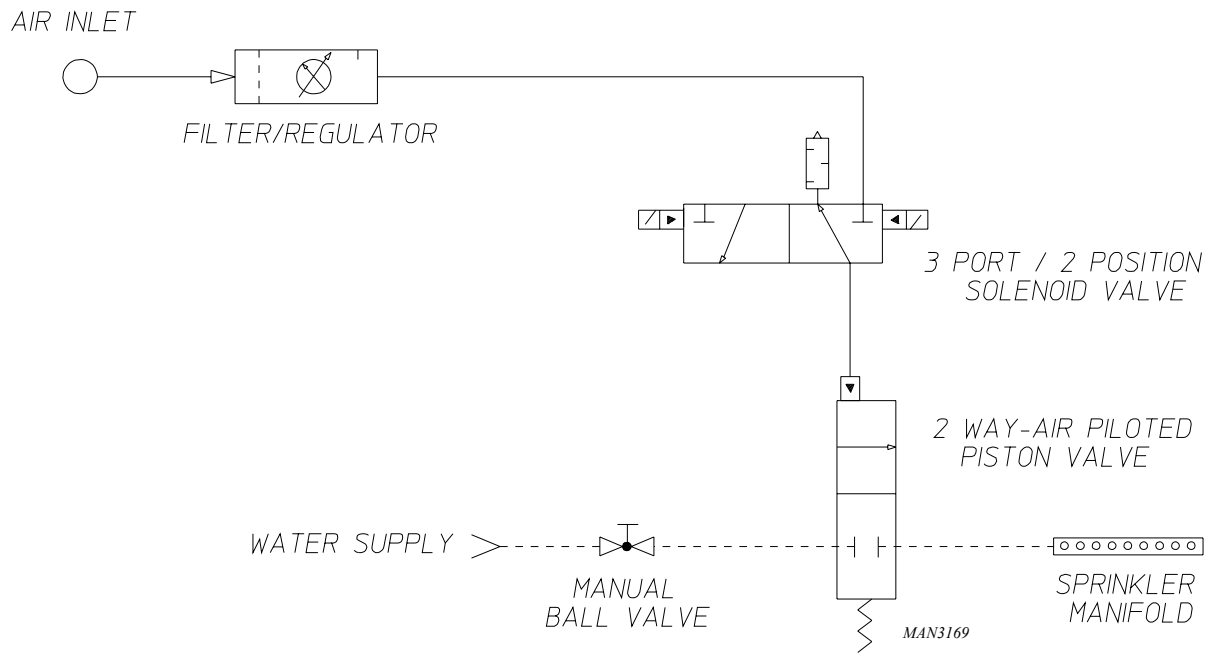

F. TILTING SYSTEM DESCRIPTION

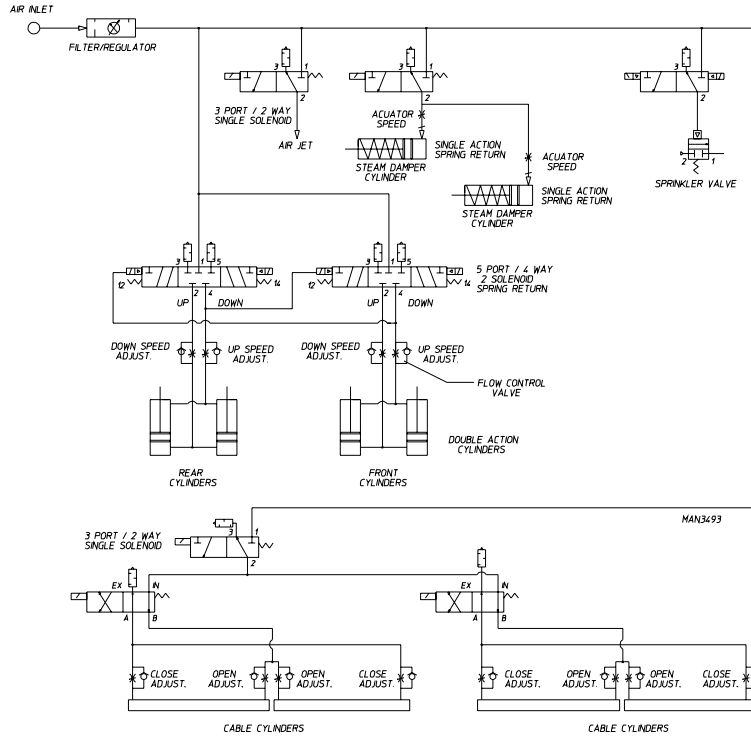

REAR UP - FRONT DOWN AIR FLOW DIAGRAM

The tilting system in the dryer, whether it be 1-way tilt or 2-way tilt, is controlled by the Micro-1 Programmable Logic Controller (PLC). The PLC (Programmable Logic Controller) will determine if the dryer is safe to tilt based on inputs from several sources. If **ALL** conditions are met, the PLC will send a signal to the tilt relays which energize the appropriate tilt solenoid valve. Compressed air is then allowed to enter the cylinders raising the tumbler.

FRONT UP - REAR DOWN AIR FLOW DIAGRAM

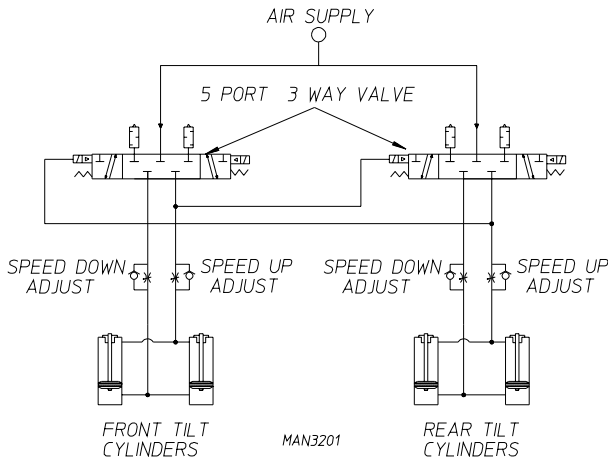

CAUTION: DO NOT USE TILT OF PISTONS AS A MEANS OF WORKING BETWEEN TUMBLER AND BASE SECTION

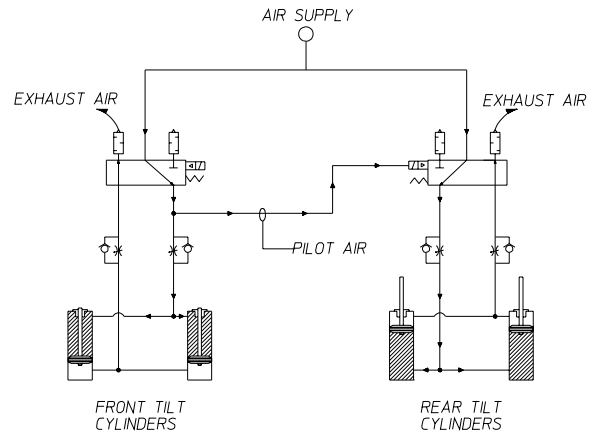

FRONT UP - REAR DOWN AIR FLOW DIAGRAM

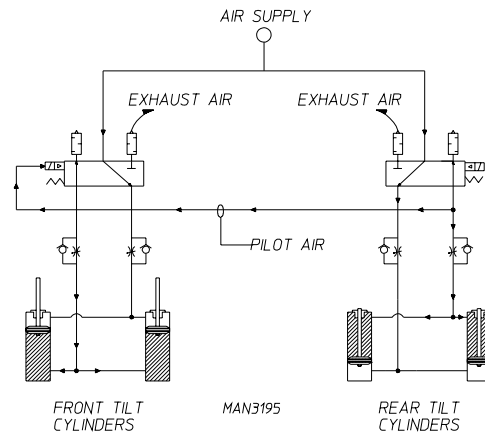

1. Speed Adjustment

The speed of the tilting action can be regulated by adjusting the set of flow control valves located on the pneumatic panel. Each set of cylinders, both front and rear, will have two (2) flow control valves. One valve will be the extend (up) air line and the other valve will be retract (down) air line. The speed of the cylinder is controlled by restricting the exhaust air flow from the cylinder. For example, if the front cylinders are extending, compressed air flows unrestricted into the cylinder causing the piston to move. The air being displaced (exhausted) from the opposite side of the cylinder can be restricted regulating the speed of extension.

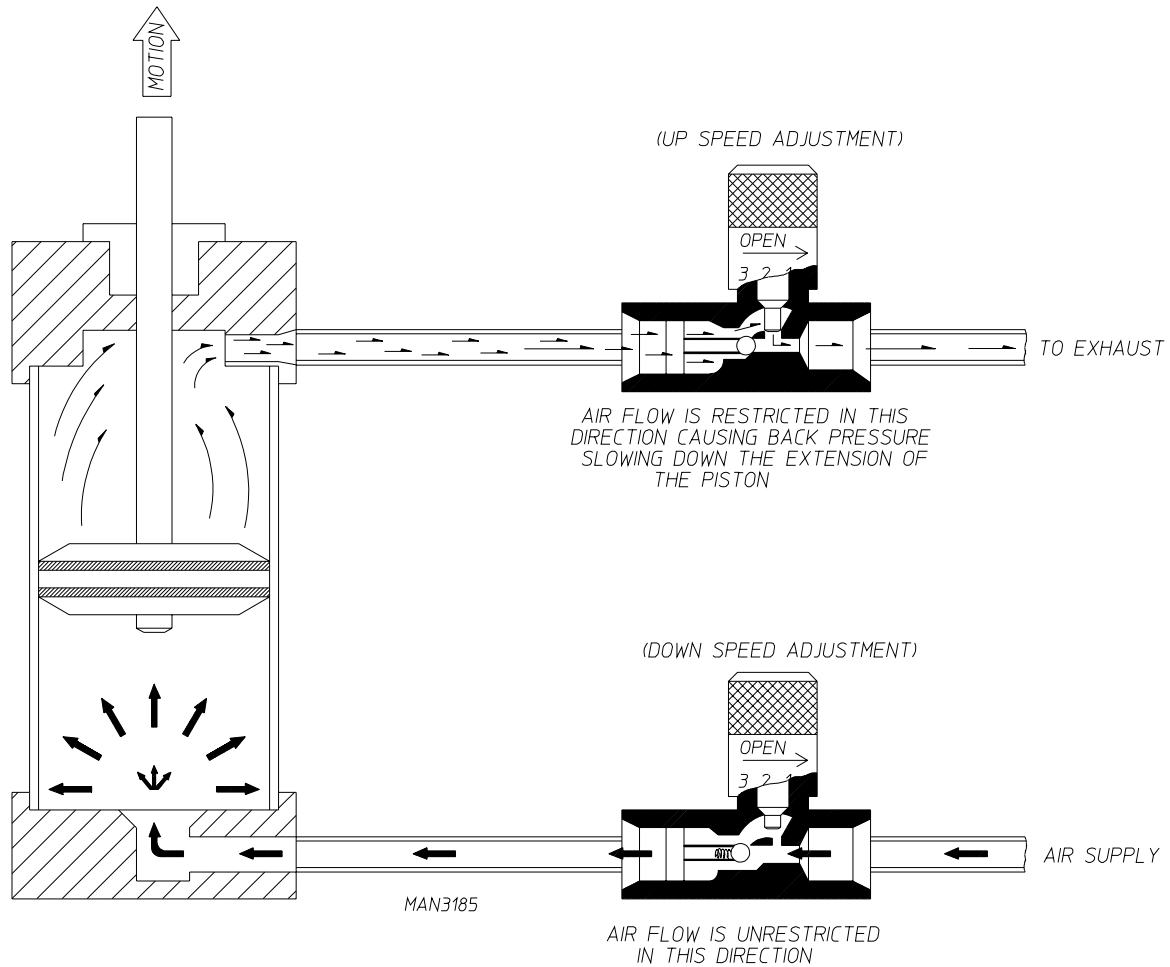

TILT CYLINDER SPEED ADJUSTMENT

2. Tilting Solenoid Valve

The dryer uses a 3-position / 4-way / 5-port, spring centering double solenoid valve. With no power applied to either solenoid, the valve is in a spring centered blocked post state. In this mode, the dryers' tilting pistons will remain in their present state, not being able to exhaust air or receive air. When the left solenoid is energized with 24 VAC, the pilot air pushes the shuttle to the right enabling air to flow into the #2 port and exhausts #4 port. On 2-Way Tilt models, this is dependent on a supply of external pilot air from the #4 port of the opposite solenoid valve. When the right solenoid of the valve is energized, air flows through the #4 port and the #2 port exhausts the pilot air, the right side of the valve is always internal pilot.

The tilting solenoid valve has two (2) mufflers. The air is exhausted through these mufflers thereby quieting the air flow.

3. Tilting Pistons

The tilting piston is a double acting cylinder that has a 5-inch bore and an 14-inch stroke. When air is applied to the bottom port of the cylinder, the piston begins to extend and air is exhausted through the top port. Then, if air is applied to the top port, the bottom port will exhaust the air which will cause the piston to retract.

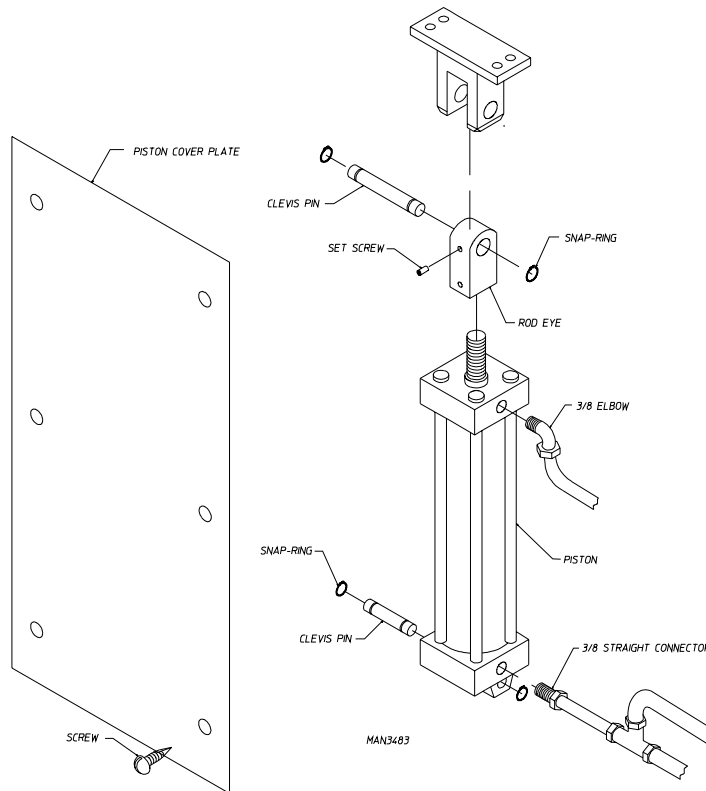

4. Tilting System Component Replacement

CAUTION: NEVER SERVICE PNEUMATIC COMPONENTS WITH COMPRESSED AIR CONNECTED. SERIOUS INJURY MAY RESULT.

a. Flow Control Valves

To replace a defective or clogged flow control valve

- 1) Disconnect compressed air supply from the dryer.
- 2) Tilt, then level the dryer to exhaust as much air as possible.
- 3) Remove the two (2) compression fittings on each side of the valve. (Refer to the **illustration** on **page 63**.)
- 4) Remove the 3/8" straight connector.
- 5) Remove the 3/8" elbow.
- 6) Remove flow control valve.
- 7) To install new flow control valve, reverse above procedure (**Step #6 through Step #1**).

b. Tilting Solenoid Replacement

- 1) Engage "EMERGENCY STOP" (E-Stop)...
Discontinue electrical service to the dryer.
- 2) Remove panel covering the pneumatic controls.
- 3) Label the solenoid plugs as an aid when reconnecting.
- 4) Loosen screws from the solenoid plug.
- 5) Remove the solenoid plug (take notice of the gaskets).
- 6) Remove the E-Clip by *gently* prying off.
- 7) Slide tilting solenoid valve up off of the post.
- 8) To install new tilting solenoid valve, reverse above procedure.

c. Tilting Solenoid Valve Replacement

- 1) Disconnect compressed air supply from the dryer.
- 2) Tilt, then level the dryer to exhaust as much air as possible.
- 3) Disengage "EMERGENCY STOP" (E-Stop)...
Discontinue electrical service to the dryer.
- 4) Label the solenoid plugs and air lines as an aid when reconnecting.
- 5) Loosen screws from the solenoid plug.
- 6) Remove the solenoid plug (take notice of the gaskets). Refer to the **illustration on page 63.**
- 7) Loosen compression fittings on the air lines...
Disconnect the three (3) air lines.
- 8) Remove the two (2) 1/4-20 hex head bolts that mount the solenoid valve. (Refer to the **illustration on page 63.**)
- 9) Remove the three (3) 3/8" straight connectors. (Refer to the **illustration on page 63.**)
Reinstall these connectors on the new solenoid valve body.
- 10) Remove the two (2) 3/8" mufflers. (Refer to the **illustration on page 63.**)
Reinstall these mufflers on the new solenoid valve body.

- 11) The left orifice (marked #12 on the tilting solenoid valve) now **must be** configured for external pilot.

NOTE: For 1-Way Tilt models proceed to **Step #23**.

- 12) Remove the two (2) Phillips head screws.
- 13) *Carefully* remove the end of the valve.

NOTE: The pieces within the end of the valve are small. Handle *carefully* to avoid losing parts.

- 14) Place the solenoid plug over the pilot orifice position of the solenoid valve end.
- 15) Place the O-ring (from **Step #13**) into the top portion of the solenoid valve end.
- 16) Place end back onto the valve removed in **Step #13**.
- 17) Replace the two (2) Phillips head screws removed in **Step #12**.
- 18) Remove Allen plug on the left side of the orifice marked #12 on the tilting solenoid valve.
- 19) Remove the pilot air's 1/4" compression fitting.
- 20) Remove the pilot air's 1/8" elbow.

Reinstall the elbow onto the new solenoid valve body.
- 21) Reconnect the three (3) air lines removed in **Step #7**.

Tighten/secure compression fittings on the air lines loosened in **Step #7**.
- 22) Bolt the solenoid valve in place using the two (2) 1/4-20 hex head bolts removed in **Step #8**.
- 23) Reconnect the three (3) air line compression fittings.
- 24) Reestablish the compressed air supply to the dryer.
- 25) Check for leaks.
- 26) Reestablish electrical service to the dryer.
- 27) Engage "EMERGENCY STOP" (E-Stop) disengaged in **Step #3**.

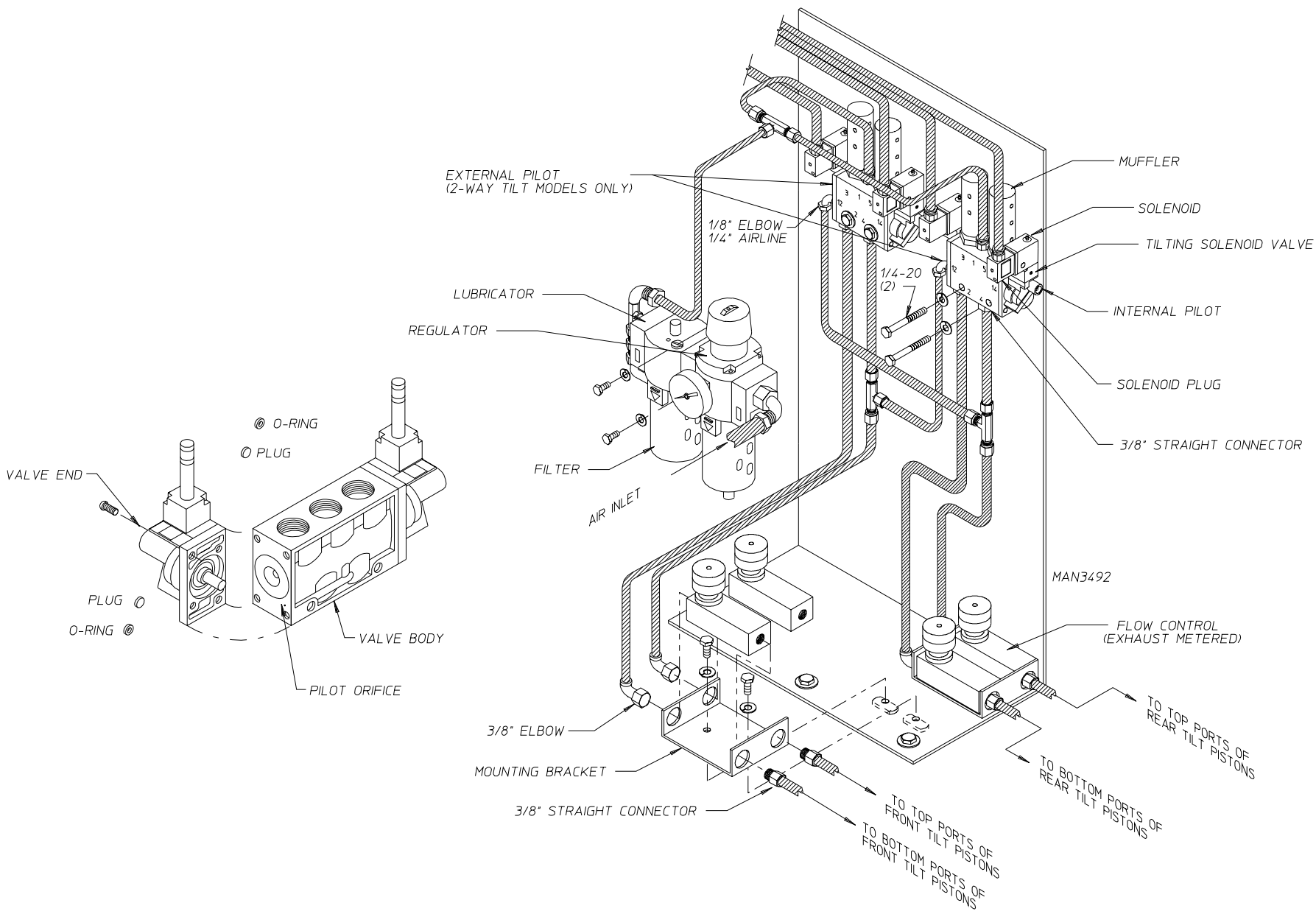

d. Tilting Piston Replacement

- 1) Disconnect compressed air supply from the dryer.
- 2) Tilt, then level the dryer to exhaust as much air as possible.
- 3) Disengage "EMERGENCY STOP" (E-Stop)...

Discontinue electric service to the dryer.

- 4) Remove the six (6) screws holding the piston cover plate.
- 5) Label the air lines as an aid when reconnecting.
- 6) Loosen the 3/8" compression fittings...
Remove the air lines.
- 7) Remove the 3/8" straight connector.
- 8) Remove the 3/8" elbow.
- 9) *Carefully* remove the E-Clips from the clevis pins.

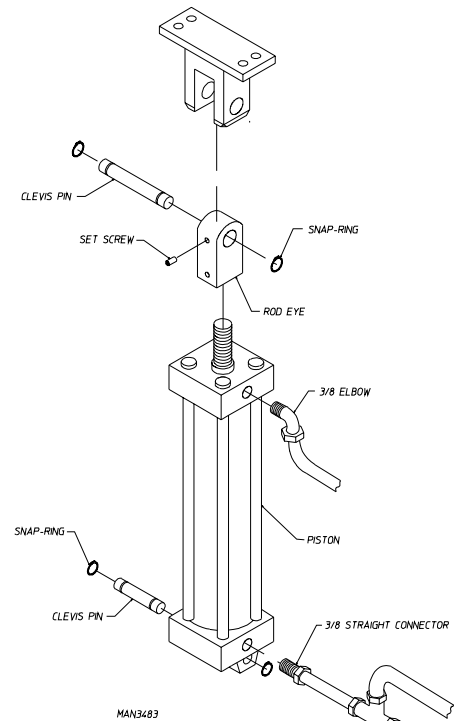
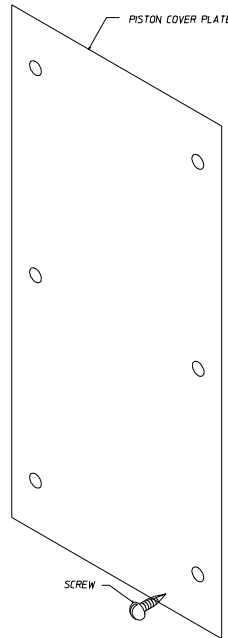

- 10) Remove clevis pins.
- 11) Loosen the bottom set screw in the piston rod eye.
- 12) Unscrew the piston rod eye from the tilting piston.
- 13) To install new tilting piston, reverse above procedure.

G. AIR JET ASSEMBLY

1. Air Jet Assembly Description

The air jet assembly is located in the left front base of the dryer. The air jet is designed to operate at the end of *each cycle* for thirty (30) seconds, to remove lint which may have accumulated on the blower (impellor) fan blades. This function will be interrupted if the main door or lint drawer is opened before the air jet cycle is complete.

2. Air Jet Component Replacement

a. 24 VAC 3-Way Pressure Valve Replacement

AIR JET ASSEMBLY WITH PNEUMATIC VALVE

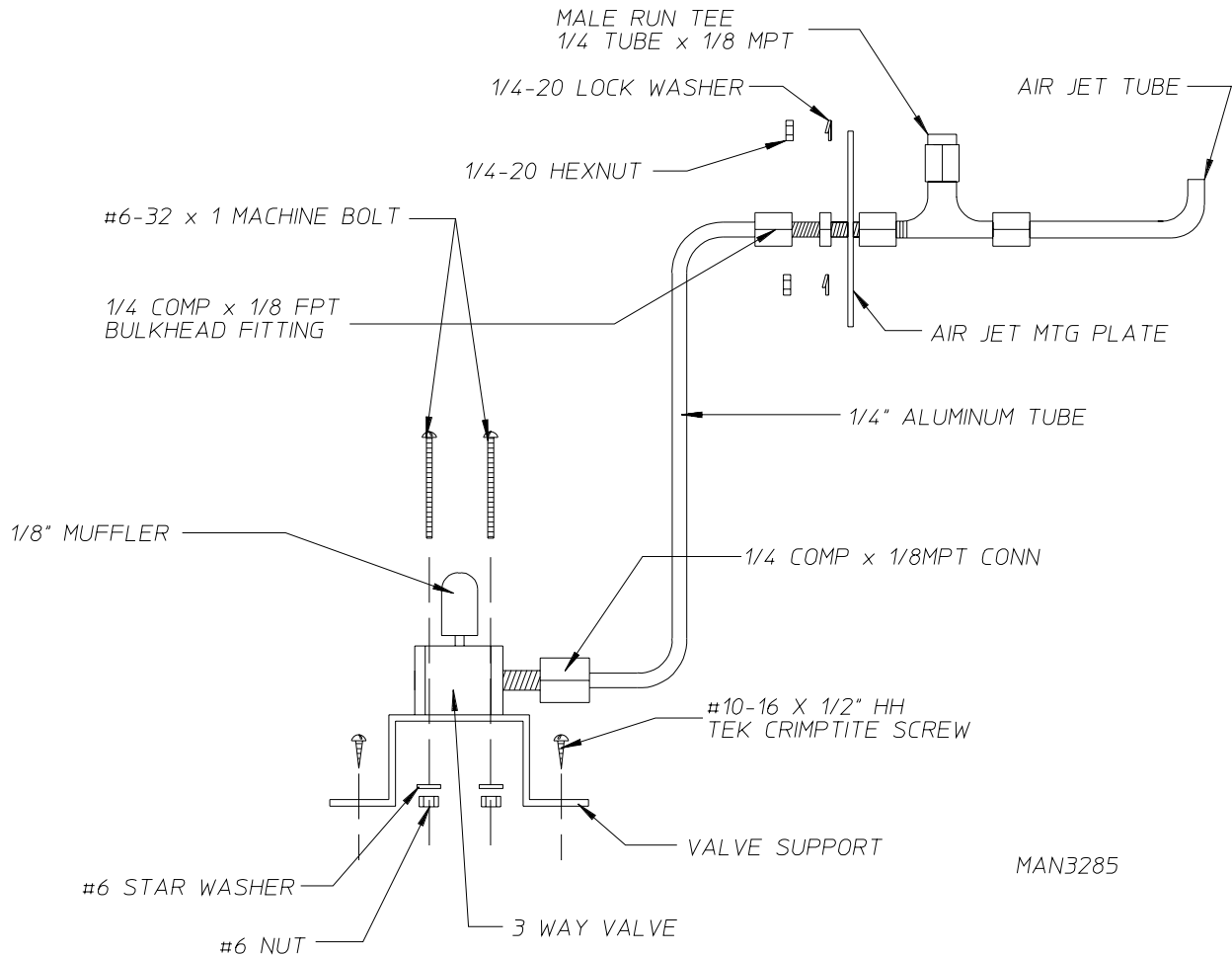

- 1) Disconnect compressed air supply from the dryer.
- 2) Discontinue electrical service to the dryer.
- 3) Remove the 1/4" x 1/8" M.P.T. connection from the 3-way pressure valve body.
- 4) Remove the two (2) #10-16 x 1/2" crimpite TEK screws.

- 5) Remove the valve support.
- 6) Remove the two (2) #6-32 x 1" hex head machine bolts by removing the two (2) #6 hex nuts and the two (2) #6 star washers.
- 7) To install new air jet assembly, reverse above procedure.

b. Pneumatic Valve Muffler Replacement

- 1) Disconnect compressed air supply from the dryer.
- 2) Remove damaged or nonfunctional muffler from valve body.
- 3) Replace muffler by threading into valve body (snug fit).
- 4) Reconnect compressed air supply to the dryer.

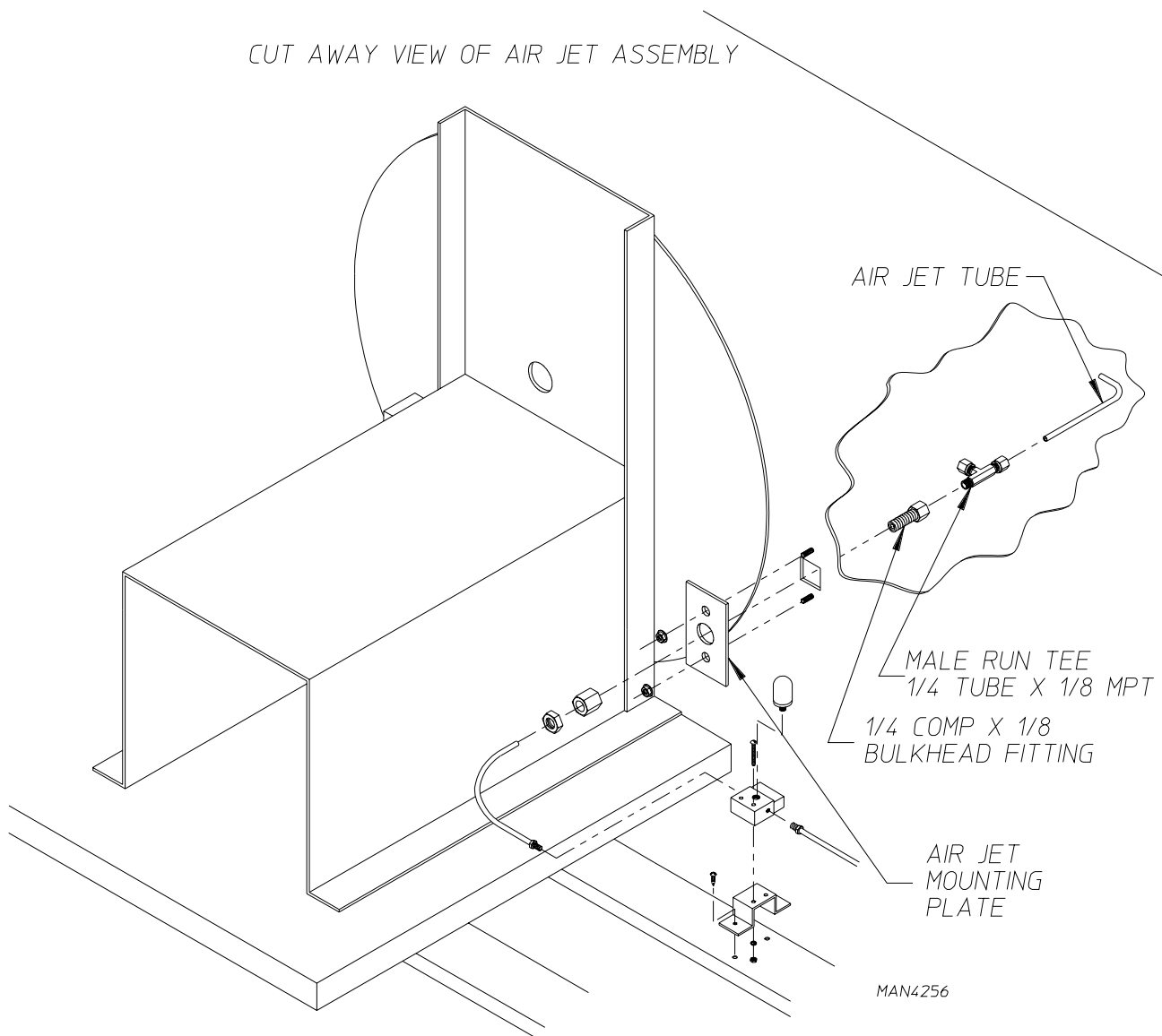

H. BLOWER (Squirrel Cage Fan) MOTOR ASSEMBLY

1. Blower (Squirrel Cage) Motor Description

The AD-310 uses an 18-inch diameter, blower (squirrel cage fan) wheel. It spins (turns) in a counterclockwise (CCW) direction when looking at the back of the blower housing.

The blower (squirrel cage fan) shaft is mounted in two (2) 1-3/8" diameter pillow block bearings, and the shaft is driven by two (2) B-section V-belts connected to the blower motor.

The blower (drive) motor is mounted on an adjustable base. The motor position can be easily adjusted so that the proper tension can be maintained on the V-belts.

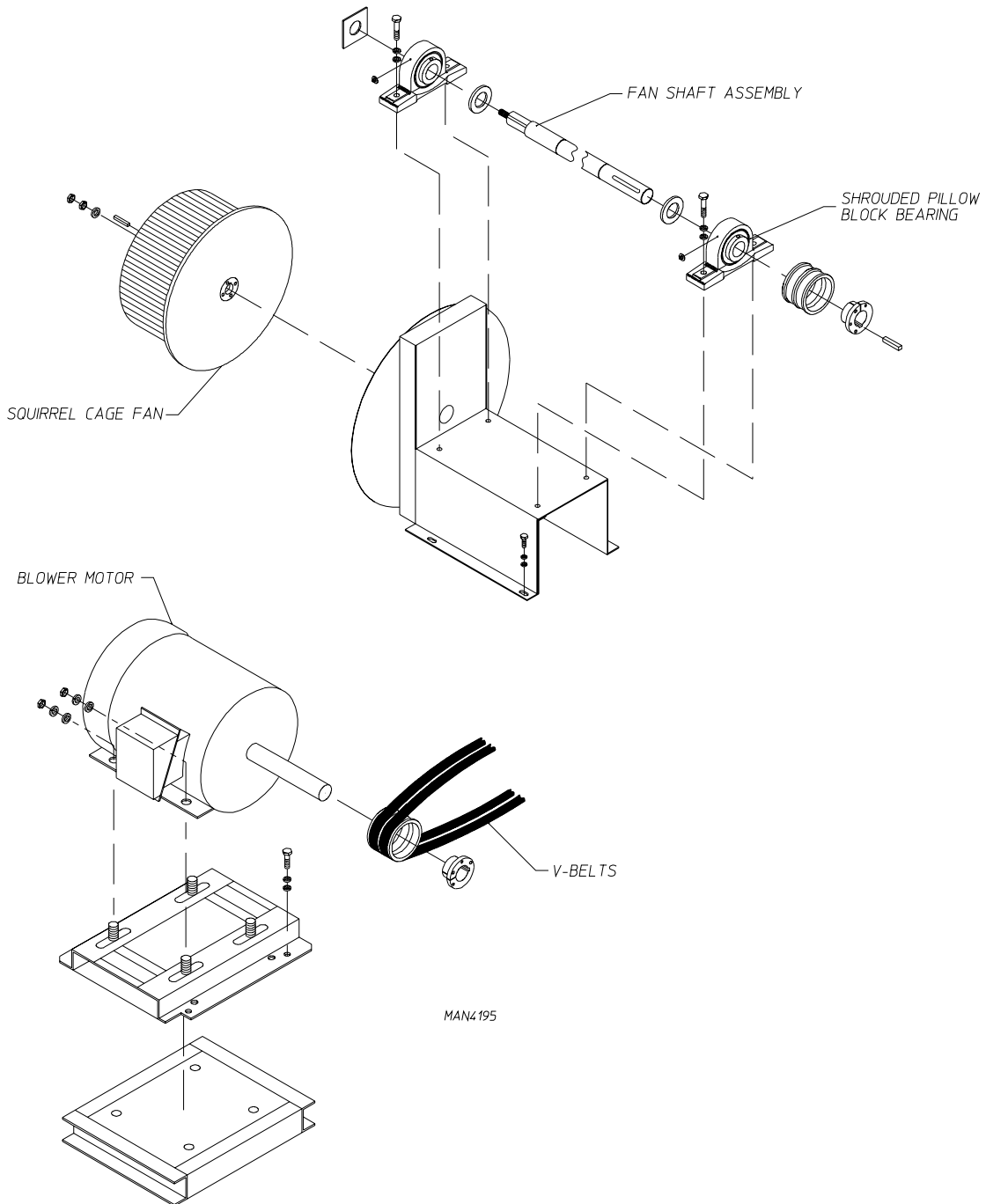

2. Blower (squirrel cage fan) and Fan Motor Component Replacement

a) Blower (squirrel cage fan) Motor Replacement

- 1) Discontinue electrical service to the dryer.
- 2) Mark and identify the wires that will be removed for proper reinstallation.
- 3) Loosen the bolts from the motor to the motor base ...
 - (a) Slide the blower (squirrel cage fan) motor forward.
 - (b) Remove the V-belts.
 - (c) Remove loosened bolts.
- 4) Remove the bolts from the bushing.
- 5) Insert bolts into the threaded holes.
- 6) Tighten the bolts evenly for motor pulley removal.
- 7) Mark the inside of the motors' shaft before removing the bushing.
- 8) Loosen the set screws on the bushing.
- 9) Remove the bushing.
- 10) Measure the mark on the shaft (from **Step #7**) to the end of the shaft and mark the new motors' shaft.
- 11) Slide the motor pulley on to the new blower (squirrel cage fan) motors' shaft.
- 12) Slide the bushing on to the shaft until the inside of the bushing meets the mark (from **Step #11**) on the new motors' shaft.
- 13) Tighten and secure the set screws on the bushing.
- 14) Insert bolts into the large holes on the bushing and thread them into the motor pulley.
- 15) Tighten the bolts evenly for motor pulley installation.
- 16) Align the pulleys.
- 17) Tighten (hand tight only) the bolts from the new motor to the motor base ...

Leave enough movement for V-belt adjustment.

PULLEY REMOVAL

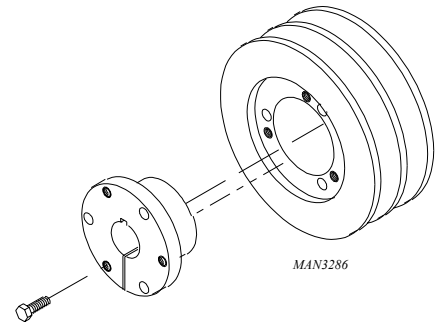

PULLEY INSTALLATION

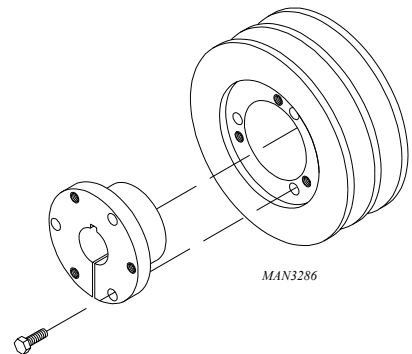

- 18) Replace the V-belts ...
 - (a) Adjust to proper tension by adjusting position of the new blower (squirrel cage fan) motor.
 - (b) Align the V-belts.
- 19) Tighten and secure the new motor to the motor base.
- 20) Rewire the new blower (squirrel cage fan) motor in the same order as the wiring from the motor that was removed.

A wiring diagram is usually affixed to the side of the motor.

- 21) Reestablish electrical service to the dryer.

b) Shrouded Pillow Block Bearing Replacement

- 1) Discontinue electrical service to the dryer.
- 2) Remove the bolts securing the blower (squirrel cage fan) motor.
 - (a) Slide the blower (squirrel cage fan) motor forward.
- 3) Remove the V-belts from the motor pulley and the pulley on the fan (blower) shaft assembly.
- 4) Move the blower (squirrel cage fan) motor so as to be able to remove the fan (blower) shaft bearing mount assembly.
- 5) Remove the bolts securing the blower (squirrel cage fan) shaft bearing mount assembly.
 - (a) Slide the fan shaft assembly with the fan (squirrel cage fan) backwards.
- 6) Remove the two (2) left hand jam nuts and the washer.
- 7) Remove the blower (squirrel cage fan) and the key.
- 8) Remove the four (4) bolts securing the shrouded pillow block bearing.
- 9) Remove the squirrel cage fan shaft assembly from the squirrel cage fan shaft bearing mount assembly ...
 - (a) Remove the pillow block on the squirrel cage fan side of the fan shaft by loosening the set screws on the pillow block bearing.
- 10) To remove the pillow block bearing on the pulley side of the fan shaft the pulley **must be** removed first ...
 - (a) Remove the bolts from the bushing.
 - (b) Insert bolts into the threaded holes.
 - (c) Mark the inside of the motor shaft before removing the bushing.

- (d) Loosen the set screws on the bushing.
- (e) Remove the bushing and the pulley.
- 11) Remove the shrouded pillow block bearing by removing the set screw.
- 12) Replace the shrouded pillow block bearing on to the fan shaft ...
 - (a) Secure the fan (blower) shaft bearing mount assembly.
 - (b) Tighten and secure the set screws in the shrouded pillow block bearing.

NOTE: Make certain that the squirrel cage fan (impellor and blower) can spin freely.

- 13) Reinstall the bushing and the pulley.
 - (a) Line up the bushing to the mark on the motor shaft and tighten and secure the set screw.
 - (b) Reinstall the bolts into the original holes and tighten evenly for correct pulley installation.
- 14) Reposition the blower (squirrel cage fan) motor to its' original position ...
 - (a) Tighten (hand tight only) the bolts into the motor and the motor base.
 - (b) Slide the blower (squirrel cage fan) motor forward.

Align the pulleys before installing the V-belts.

IMPORTANT: *DO NOT OVERTIGHTEN V-BELTS.*

- 15) When V-belts are properly tensioned, tighten and secure the motor to the motor base.
- 16) Reestablish electrical service to the dryer.
- c) Squirrel Cage Fan (impellor) Replacement
 - 1) Discontinue electrical service to the dryer.
 - 2) Remove the bolts securing the blower (squirrel cage fan) motor.
 - 3) Remove the V-belts.
 - 4) Slide the blower (squirrel cage fan) motor to the side.
 - 5) Remove the bolts from the blower (squirrel cage fan) shaft bearing mount assembly.
 - (a) Slide the blower (squirrel cage fan) shaft bearing mount assembly backwards.
 - 6) Remove the two (2) left hand jam nuts and the washer.

7) Remove the key on the blower (squirrel cage fan) shaft.

(a) Slide the blower (squirrel cage fan) off of the shaft.

NOTE: Install this key on to the fan shaft before installing the new blower (squirrel cage fan).

8) To install blower (new squirrel cage fan) , reverse above procedure.

d) V-Belt Replacement

1) Discontinue electrical power to the dryer.

2) Loosen the bolts securing the blower (squirrel cage fan) motor.

(a) Ease off on the tension bolt.

3) Slide the blower (squirrel cage fan) motor forward.

4) Remove and replace V-belts.

5) Tighten and secure the tension bolt.

IMPORTANT: *DO NOT OVERTIGHTEN V-BELTS.*

6) Using a straight edge, make certain that the motor pulley and V-belts are aligned straight.

7) Tighten and secure bolts from motor to motor base.

8) Reestablish electrical service to the dryer.

e) Fan (impellor) Shaft Replacement

The procedure to replace the Fan Shaft is the same procedure used to replace the Shrouded Pillow Block Bearing (refer to **previous pages (page 69 and page 70)**).

3. Blower (squirrel cage fan) Electrical Components

a) Blower (squirrel cage fan) Controls and Overloads

1) Thermal Magnetic Starter (TMS)

The thermal magnetic starter is used as a *safety device* to protect the motor from starting in a locked rotor condition. The overload has a dial setting on the face of the device. To set the overload, refer to your specific electrical diagrams. The overload is specifically designed for motor applications. It has a current curve built into it so the initial high current draw by the motor will not trip the overload. On the face of the overload, there are two (2) push buttons - "START" (Black or Tan - 1) and "STOP" (Red - 0) - the overload **has to be** in the "START" mode for the motor to run.

(a) Thermal Magnetic Starter (TMS) Replacement

- (1) Discontinue electrical service to the dryer.
- (2) Mark L1, L2, L3, and T1, T2, T3 on the wires to the TMS for correct replacement.
- (3) Set the amp rating on the TMS according to the manufacturers electrical schematic on the new thermal magnetic starter.
- (4) To remove the thermal magnetic starter, pull the tab on the bottom and lift upward.
- (5) To install new thermal magnetic starter, reverse above procedure.

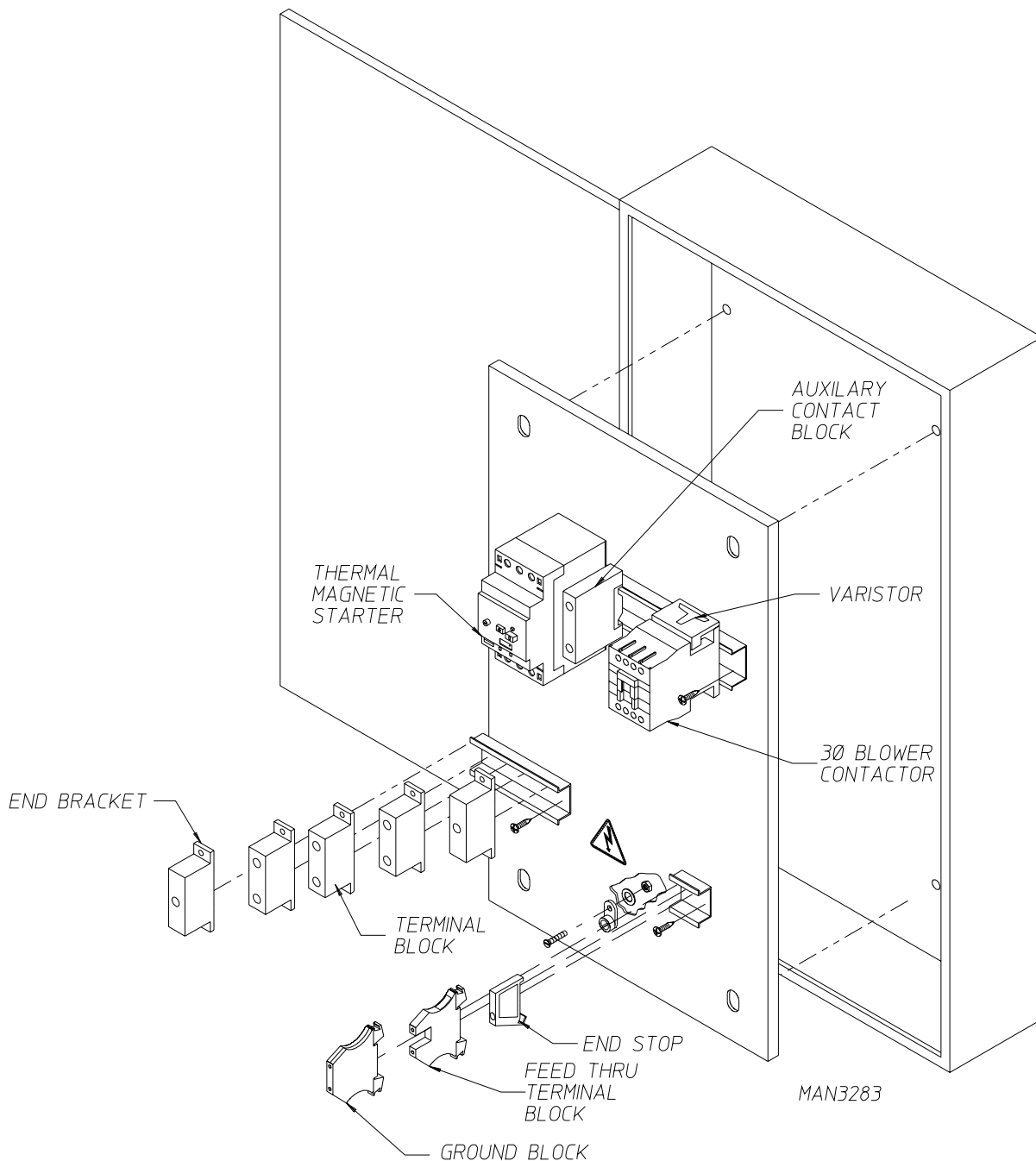

2) Auxiliary Contact Block

The Auxiliary Contact Block is mounted on the side of the overload. Its' function is to sense an over-load trip, thereby triggering a safety fault which will disable the drying cycle. A "DOOR" message will appear on the L.E.D. (light emitting diode) display on the Phase 5 microprocessor controller (computer).

(a) Auxiliary Contact Block Replacement

- (1) Discontinue electrical power to the dryer.
- (2) Remove the Thermal Magnetic Starter (TMS) from the din rail by pulling the tab on the bottom of the contact block and lifting upward.
- (3) Remove the two (2) wires going to the auxiliary contact block and label for correct reinstallation.
- (4) There are two (2) types of auxiliary contact blocks... one with a screw and the other with a clip ...

To remove the style with the screw from the thermal magnetic starter simply remove the screw.

To remove the style with a clip simply push in the clip and remove.

- (5) To install new auxiliary contact block, reverse above procedure.

3) Varistor (MOV)

The Varistor - MOV (Metal Oxide Varistor) is used to suppress any inductive electrical spikes produced by the energizing and collapsing of the coil voltage.

(a) Varistor (MOV) Replacement

- (1) Discontinue electrical service to the dryer.
- (2) Loosen the screws marked A1 and A2 on the contactor.
- (3) Remove the varistor.
- (4) Verify that no additional wires were inadvertently removed.
- (5) Reverse procedure to install new varistor.

I. FILTER and REGULATOR ASSEMBLY

The purpose of the filter is to remove bulk liquids and solid particles from the compressed air stream. The filter element provides mechanical separation of solids. Centrifugal force inside the filter bowl separates bulk liquids and larger solid particles.

The filter consists of a louver which causes a centrifugal spinning action to separate contaminants. A filter which mechanically separates contaminants is also present. The filter bowl collects the contaminants and a baffle prevents turbulence from picking up contaminants at the bottom of the bowl and returning them to the air stream.

1. Filter Maintenance

- a. To remove filter element ...

Twist the filter bowl 1/8 turn clockwise (CW). Then pull the bowl down to expose the filter element. To remove the filter element, unscrew the baffle (this will allow element removal).

- b. To clean filter element ...

The filter element can be cleaned with soap and water.

NOTE: When replacing the filter element bowl care *must be* taken to ensure that the O-ring *does not* get *pinched*.

2. Regulator Operation

The adjustment knob simply acts upon a spring rest located on the spring and directly compresses the spring as it is adjusted. A non-rising low torque adjustment screw is used on this type of filter and regulator. The upper spring rest is located on top of the regulator spring and transmits force from the adjustment screw to the spring. Regulators use simple wire coil springs for controlling the downstream regulator pressure. The bonnet houses the adjustment spring and is used to help retain the diaphragm. The diaphragm moves up when the downstream pressure reaches its preset pressure level, which in turn closes the valve. A self-relieving regulator is designed to automatically relieve overpressure in the secondary side of the regulator.

NOTE: THIS SELF-RELIEVING FEATURE *IS NOT* DESIGNED TO BLEED THE DOWNSTREAM PRESSURE.

Dryer must be provided with a clean, dry, regulated 80 PSI (+/- 10 PSI) air supply (equivalent volume - 9 cfh).

The regulator **should be** set at 80 PSI (+/- 10 PSI). To set pressure, pull the adjusting knob up and either turn the knob clockwise (CW) to increase the pressure or counterclockwise (CCW) to decrease the pressure.

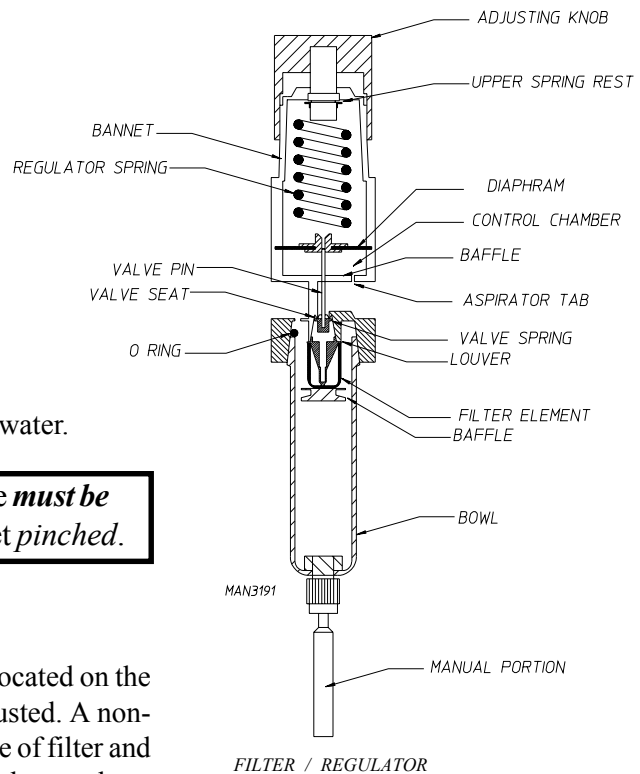

J. DOOR SYSTEMS

The dryer utilizes two (2) styles of doors, which are Manual Doors and Pneumatic Automatic Doors.

1. Manual Door Description

The Manual Doors run on a single aluminum track with a wheel assembly mounted above the doors and a channel with teflon strips mounted on the bottom of the doors ...

- a. For dryers manufactured as of November 1, 1995, there are trolley bolts located at the top of the doors to secure the doors onto the track.
- b. For dryers manufactured prior to November 1, 1995, there are two (2) adjustment plates located at the top of the doors to secure the doors onto the track.

In the center portion on the top of the doors there is a magnet used in conjunction with proximity sensors which are mounted above the doors.

2. Pneumatic Automatic Description/Operation

a. Description

The Pneumatic Automatic Doors run on a single aluminum track mounted above the doors and a split track mounted on the bottom of the doors. The doors are held on the track by four (4) stainless steel wheel assemblies; two (2) are located on the top of the doors and two (2) are located on the bottom of the doors. Additionally, in the center portion on the top of the doors there is a magnet used in conjunction with proximity sensors which are mounted above the doors.

b. Operation

There are two (2) 1" bore x 18-3/8" stroke cable cylinders attached to the top of the doors to pneumatically open and close the doors. When air is applied into the outside ports of these cable cylinders the doors will open. If air is applied into the inside ports of these cable cylinders the doors will close. On each of the four (4) ports is a flow control valve used for adjusting the opening and closing speeds of the doors. These flow controls only vary the speed in the exhaust direction. Air to the cable cylinders is supplied through a 4-way valve. When 24 VAC is applied to the valve, the doors open... if no power is applied, the doors close. A 3-way valve is used to supply air to the 4-way valve.

If the "EMERGENCY STOP" (E-Stop) is engaged, the air is automatically exhausted so that the doors can be opened manually.

- 1) In a 2-Door application, there are two (2) additional cable cylinders a 4-way valve added for the operation of the rear doors.

3. Door Component Replacement and Removal

a. Manual Door Replacement or Removal

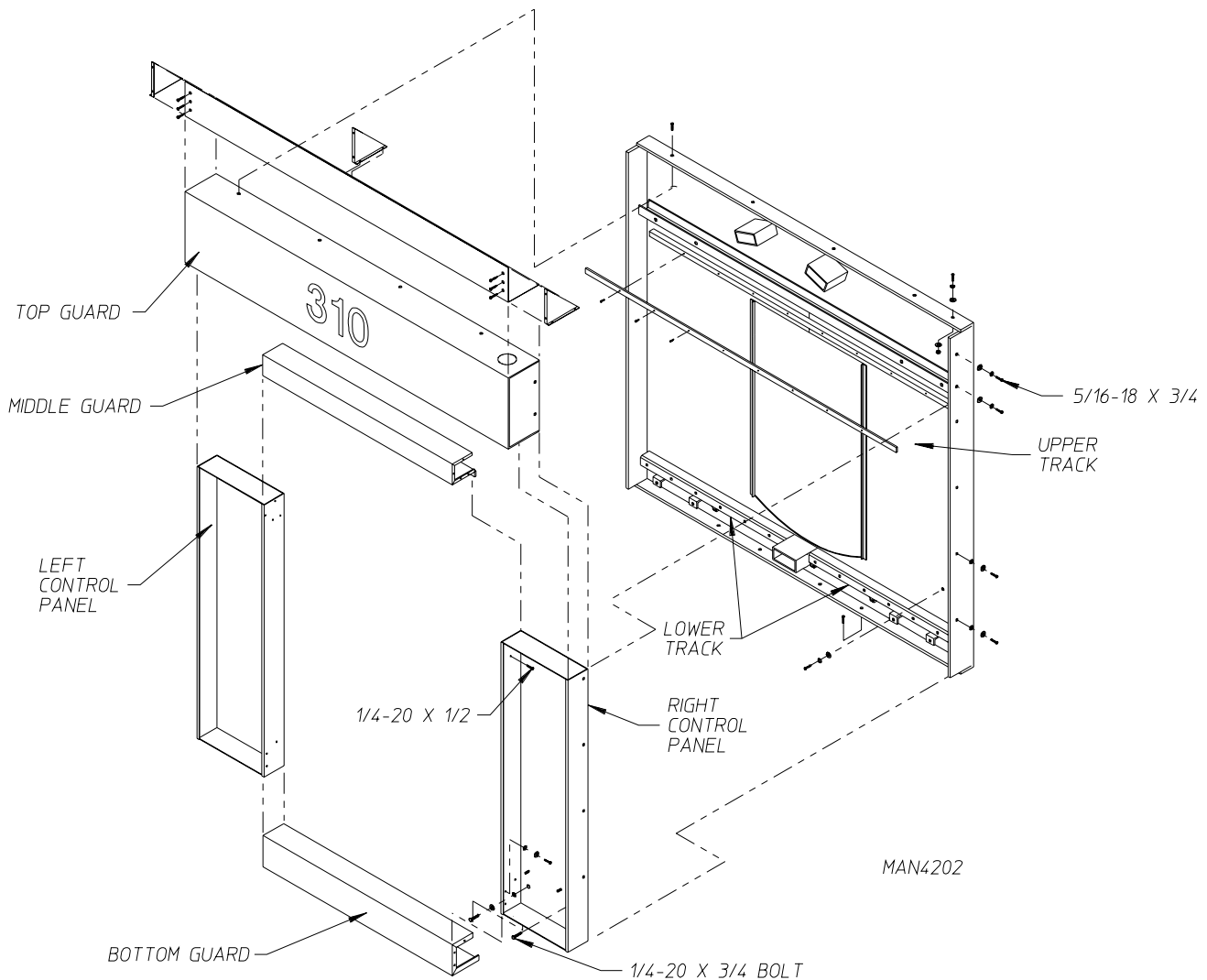

- 1) Discontinue electrical service to the dryer.
- 2) Remove the two (2) 1/4-20 x 1/2" bolts from each side of the middle guard and then remove the guard.
 - a) For dryers manufactured as of November 1, 1995, loosen the jam nut and screw down the trolley adjustment bolts.
 - b) For dryers manufactured prior to November 1, 1995, remove the two (2) trolley adjustment plates.
- 3) Lift the door(s) off of the track(s) and remove.
- 4) To install new manual door(s) or to reinstall manual door(s), reverse above procedure **Step #3 through Step #1**.

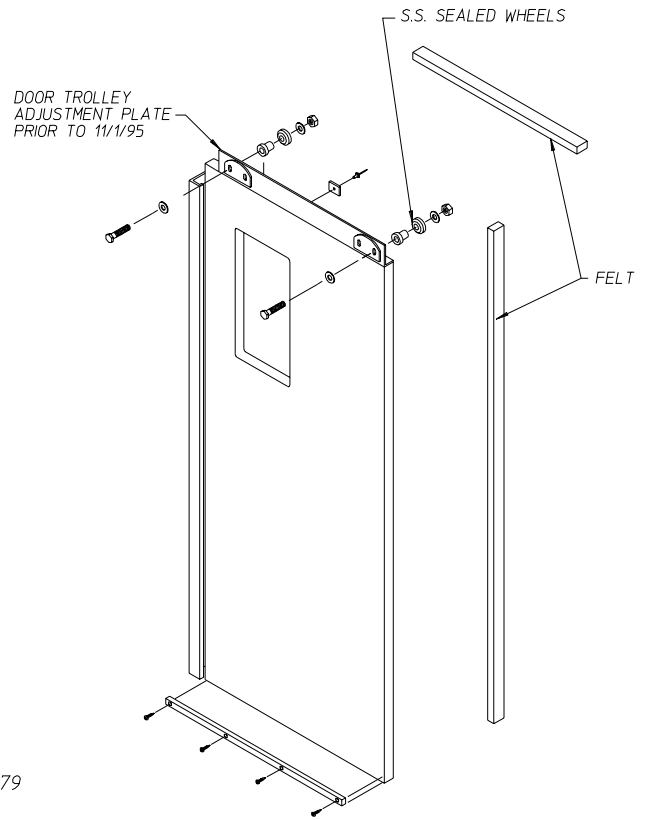
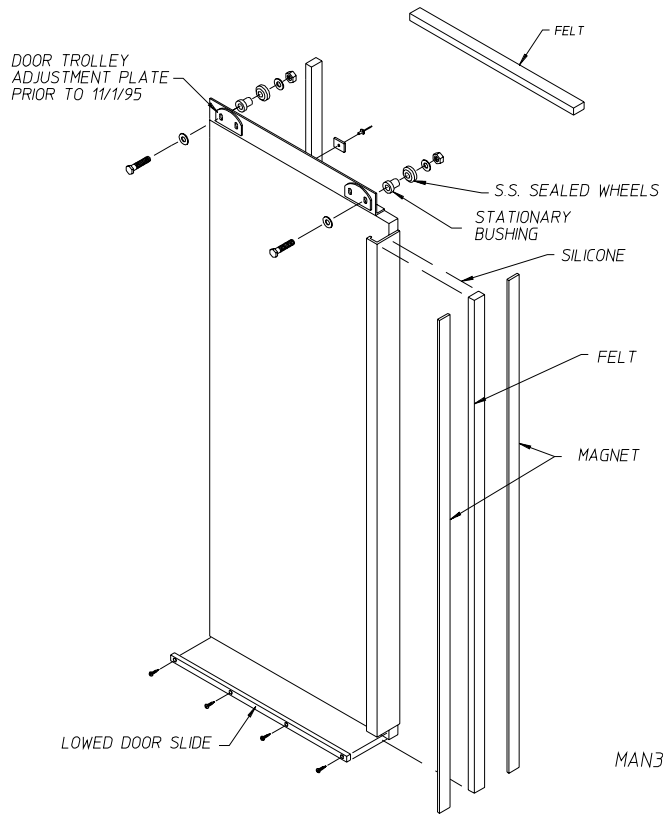
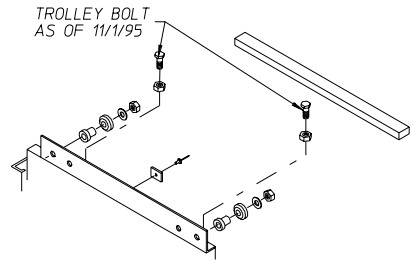
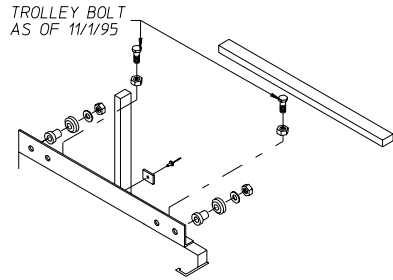

MAN3279

b. Pneumatic Automatic Door Replacement or Removal

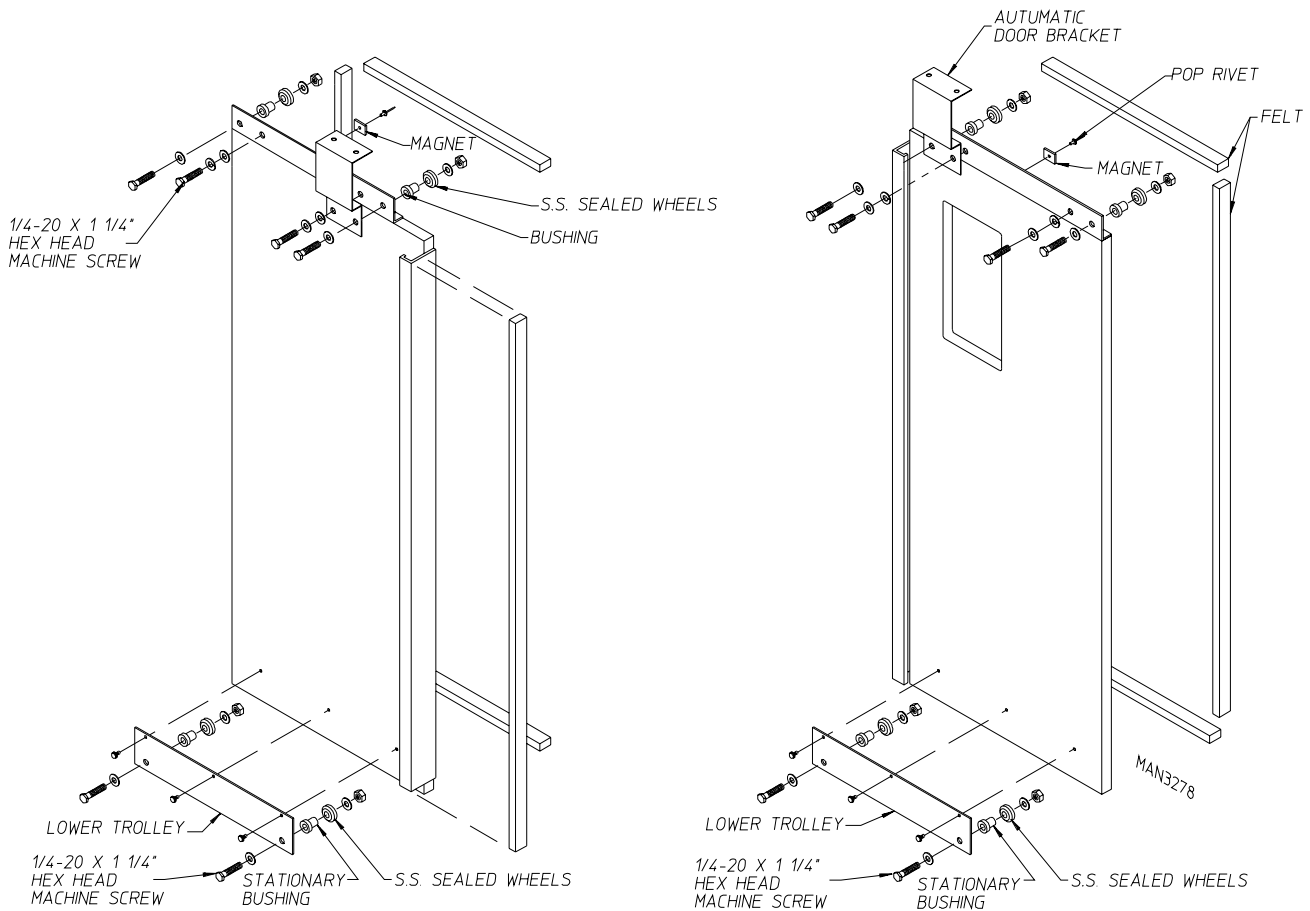

- 1) Discontinue electrical service to the dryer.
- 2) Remove the two (2) 1/4-20 x 1/2" bolts from each side of the middle guard.
Remove the middle guard.
- 3) Remove the three (3) 1/4-20 x 3/4" bolts from the bottom guard.
Remove the bottom guard.
- 4) Remove the two (2) 8-32 x 3/4" screws on each door that connect/attach the cable cylinder to the door.
- 5) Remove the two (2) 1/4-20 x 1-1/4" hex head machine screws that hold the wheels on ...
 - a) Take notice to the wheel assembly configuration.
- 6) Lift the doors off of the track and remove.
- 7) To install new pneumatic automatic doors or to reinstall pneumatic automatic doors, reverse above procedure.

c. Cable Cylinder Replacement or Removal

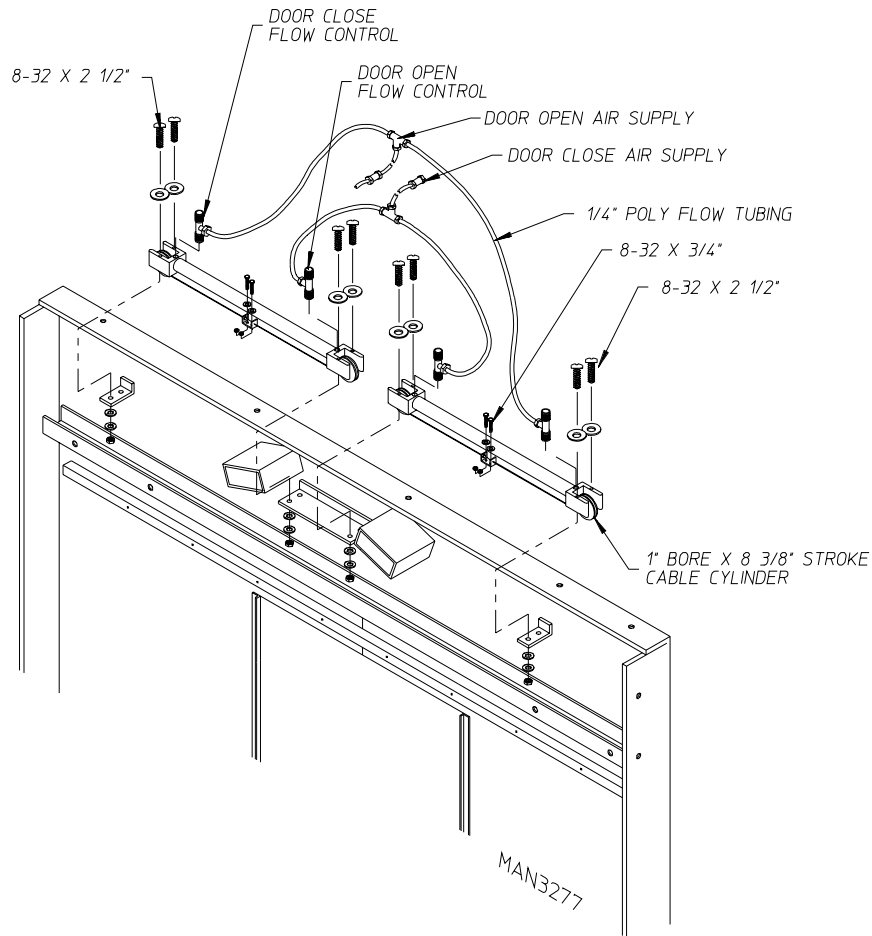

- 1) Discontinue electrical service to the dryer.
- 2) Remove the two (2) 1/4-20 x 1/2" bolts from each side of the middle guard. (Refer to the **illustration** on **page 76**.)

Remove the middle guard.
- 3) Disconnect the cables in the top of the electrical panel.
- 4) Remove the hardware from the top guard.

Remove the top guard.
- 5) Remove the two (2) 8-32 x 3/4" screws on each door that attach the cable cylinder to the door.
- 6) Remove the four (4) 8-32 x 2-1/2" screws that hold each cable cylinder.
- 7) Remove the flow control valve ...
 - a) The flow control valve has a quick disconnect on the poly flow tubing side ...

Push the tubing in while holding in then pull the tubing out.
- 8) To install new cable cylinder(s) or reinstall cable cylinder(s), reverse above procedure.

d. Proximity Switch Replacement

- 1) Discontinue electrical service to the dryer.
- 2) Remove the two (2) 1/4-20 x 1/2" bolts from each side of the middle guard and then remove the guard.
- 3) Remove the three (3) 1/4-20 x 3/4" bolts from the bottom guard.

Take notice of the depth of the proximity switch.

- 4) Unscrew and remove the nut that is on the bottom of the proximity switch.
- 5) Install new proximity switch.
- 6) Set gap between the proximity switch and the magnet at 3/16" (+/- 1/32").
- 7) Reinstall middle guard and secure with the bolts removed in **Step #2**.
- 8) Reestablish electrical service to the dryer.

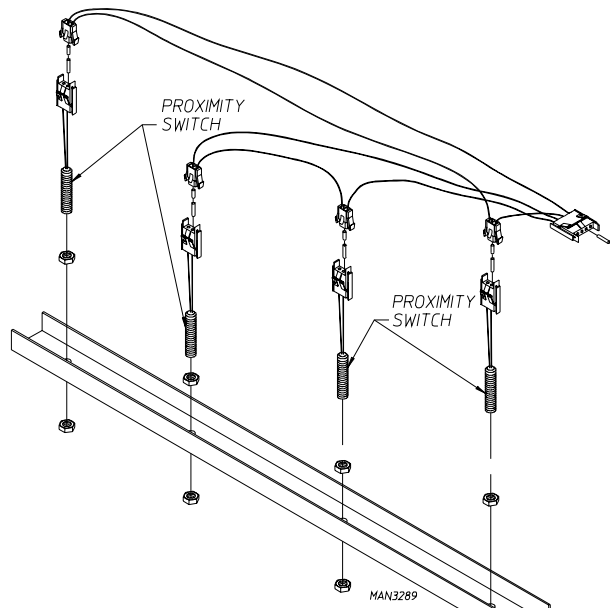

e. Right Load Door Glass (Window) Replacement

- 1) Remove **ALL** of the old silicone from around the door glass.
- 2) Clean glass door opening (with alcohol) to remove **ALL** foreign residue.
- 3) Carefully clean new door glass with alcohol prior to installation.
- 4) Apply a bead of silicone (**ADC Part No. 170730**) to the outer perimeter of the door glass opening.

Carefully insert new door glass within door glass opening.

- 5) Allow a full 72 hours for the silicone to cure.
- 6) Trim excess silicone (with razor blade) after cure time.

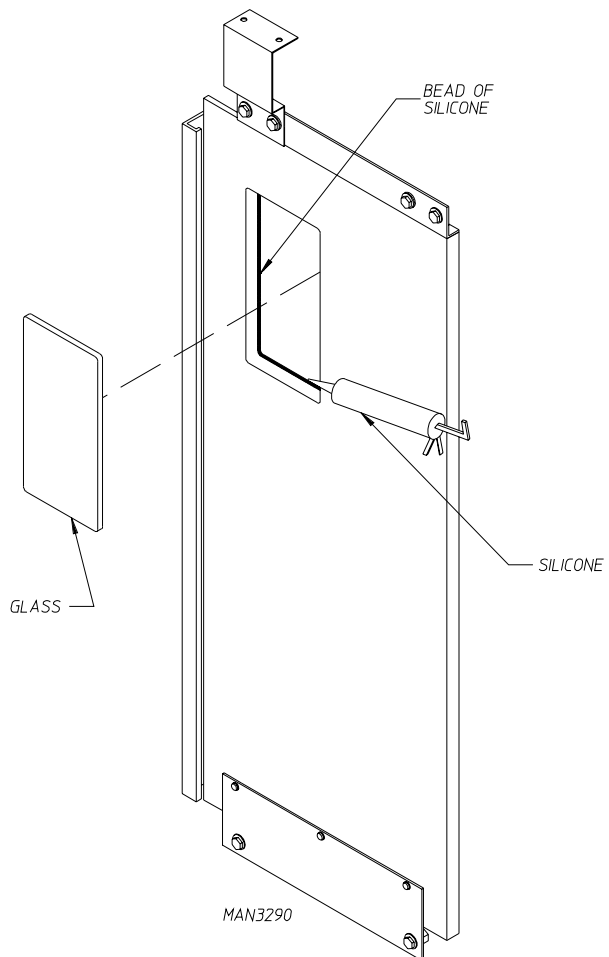

f. 4-Way Valve, and 3-Way Valve and Supply Air Disable Valve Replacement

- 1) Discontinue electrical service to the dryer.
- 2) Disconnect compressed air supply from the dryer.
- 3) Remove the 1/4-20 self-tapping screws securing the pneumatic panel cover.
- 4) Remove the two (2) 1/4-20 screws securing the junction box cover.
- 5) Loosen the cord grip cap that the valve wire go through.
- 6) Loosen the appropriate wire on the terminal strip.

Identify these wires and make note of their placement.

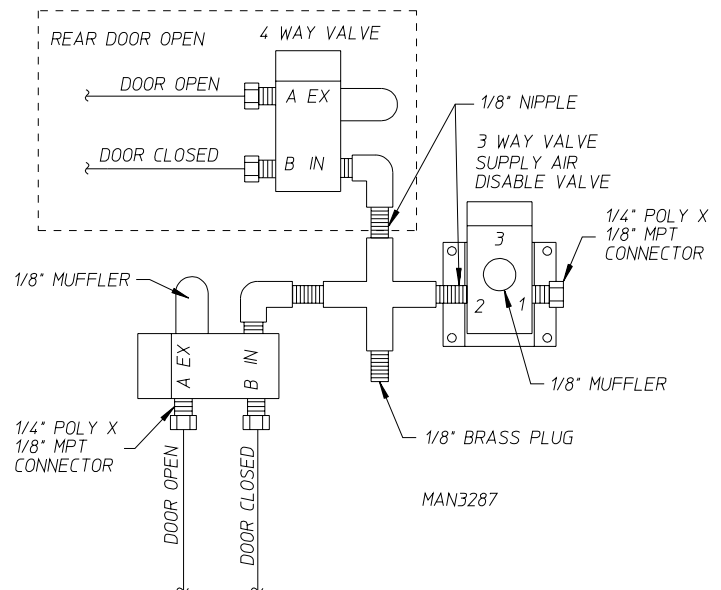

- 7) Loosen the bolts holding the assembly to the pneumatic panel.

(For 3-way valve/supply air disable valve replacement proceed to **Step #13.**)

- 8) Remove the two (2) 1/4" poly compression fittings (door open - door close).
- 9) Remove the two (2) 1/4" poly x 1/8" M.P.T. connectors from the valve body.
- 10) Twist/remove the 4-way valve body off of the 1/8" street elbow.
- 11) Remove the muffler off of the valve body.
- 12) To install new 4-way valve, reverse above procedure (**Step #11 through Step #1**).
- 13) Remove the 1/4" poly compression fitting.
- 14) Remove the 3-way valve and supply air disable valve from the 1/8" M.P.T. nipple.
- 15) Remove the muffler off of the valve body.
- 16) To install new 3-way valve and supply air disable valve, reverse **Step #1 through Step #7, Step #13, Step #14, and Step #15.**

K. Control and Electrical System

Ladder Diagram

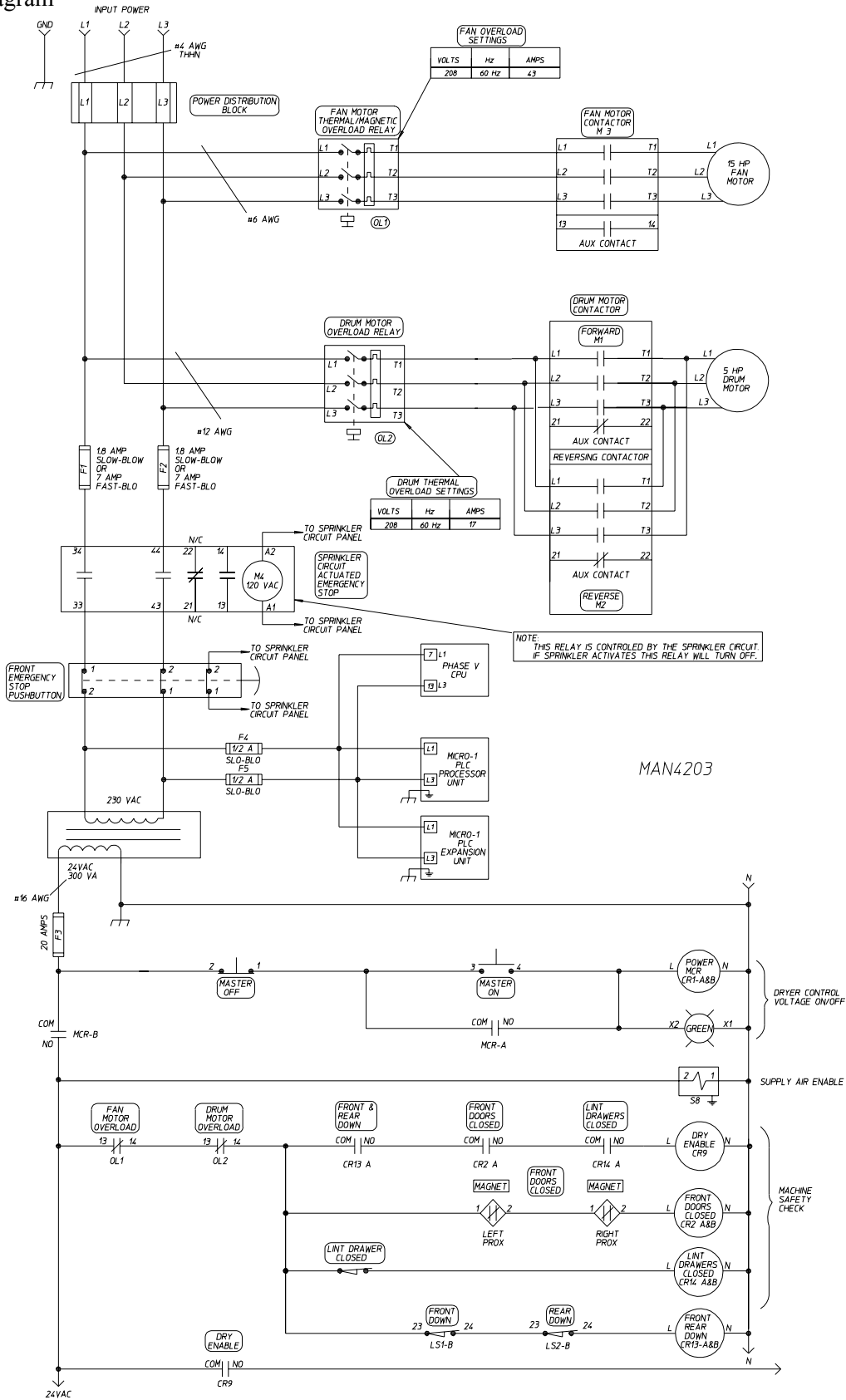

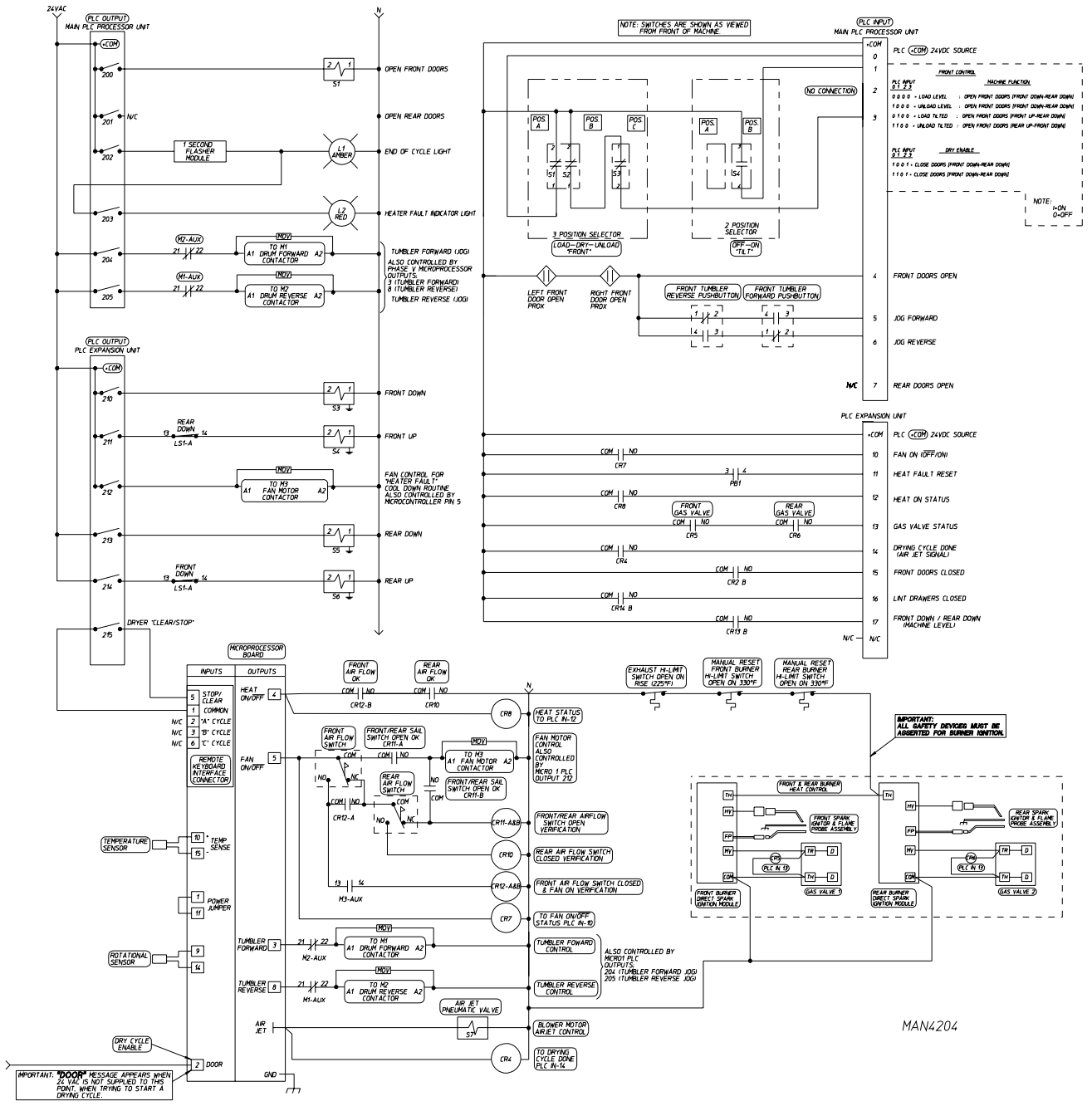

CAUTION: When servicing the HIGH VOLTAGE section of the dryer, the ELECTRIC SERVICE *MUST BE* DISABLED. THE "EMERGENCY STOP" (E-Stop) BUTTON *DOES NOT* DISABLE THE HIGH VOLTAGE TO THE DRYER.

1. Control/Electrical System Description

a. 3-Phase (3 ϕ) Electrical Power

The 3-phase (3 ϕ) electrical power for the dryer enters the dryer through the power distribution block located in the dryer base electrical box. It is then distributed to the blower (impellor/fan) motor, drive (tumbler/basket) motor, and transfer circuits.

1) Blower (squirrel cage fan) Motor

The Blower (squirrel cage fan) Motor circuit consists of a blower motor thermal magnetic overload. The overload current is adjustable by a dial located on the face of the overload. (Refer to the electrical specification diagram for correct current setting.)

Attached to the thermal magnetic starter is an auxiliary contact used to sense an overload trip. This produces a safety error so the dryer service is disabled (the dryer will not start).

In series with the thermal magnetic overload is the blower motor contactor. This device enables the supply voltage to reach the blower (squirrel cage fan) motor. The blower motor contactor is controlled by the Phase 5 microprocessor controller (computer). (Refer to **Section b-1** on **page 86** for micro-processor [computer] information.) When 24 VAC is applied to coil A1-A2, the contactor closes and enables the circuit.

The blower (squirrel cage fan) motor used for gas model dryers is 15 HP (horsepower) and for steam model dryers is 25 HP (horsepower). The motor wiring configuration is dependent on the specific voltage of the dryer. When wiring the motor, refer to the motor nameplate.

2) Drive (tumbler and basket) Motor

The Drive (tumbler and basket) Motor is supplied by the 3-phase (3 ϕ) power source entering the drive motor thermal magnetic overload. The overload current is adjustable by a dial located on the face of the overload. (Refer to the electrical specification diagram for correct current setting.) In this circuit, the drive motor contactor follows the thermal magnetic overload.

The drive motor has two (2) separate sets of coils and two (2) separate sets of contacts. One (1) of these sets is for forward tumbler (basket and drum) rotation and the other for reverse tumbler (basket and drum) rotation. The thermal magnetic overloads and the contactors are located in the left hand electrical cabinet. The direction of the drive motor is determined by the phases going into the motor (i.e., in a reverse direction phase, L1 and L2 are switched). When viewing this contactor (from the front of the dryer), the left hand block connections are for the forward rotation direction (clockwise [CW]).

The drive (tumbler and basket) motor is a 5 HP (horsepower) motor. Refer to the motor nameplate for specific terminal box wiring.

3) 24 VAC Transformer

The 24 VAC transformer consists of fuse 1 (F1) and fuse 2 (F2) which is the primary fusing for the transformer. For the proper rating of these fuses refer to the specific electric diagram. The transformer is located in the right hand electrical cabinet.

Dryer models with an *optional* Sprinkler System have an energizing stop relay which will disable the dryer functions (shut the dryer down) in the event of a fire. **IF THE SPRINKLER SYSTEM IS NOT ENERGIZED (POWERED) THE DRYER WILL NOT OPERATE.** The Energizing Stop Push Button is located on the front right electrical panel. On 2-Door models this Energizing Stop Push Button is located on the right rear side of the electrical panel (when viewed from the rear).

On dryer models manufactured for 208 volt or 240 volt electric service, the step down voltage for the Phase 5 microprocessor controller (computer) and the Programmable Logic Controller (PLC) is supplied from the primary side of the 24 VAC transformer. On dryers that are manufactured for 380 volts and higher, there is an additional secondary 240 VAC on the transformer that is used to supply the voltage required to operate the Phase 5 microprocessor controller (computer) and the Programmable Logic Controller (PLC) through fuse 4 (F4) and a fuse (F5) in 208/240 VAC applications.

4) 24 VAC Control Circuit

The secondary side of the 24 VAC transformer supplies 24 VAC to various control circuits through fuse 3 (F3) and a 20-amp fuse or an 8-amp fuse (fuse amperage [rating] is dependent on the voltage that the dryer was manufactured with).

The first circuit is the control voltage on/off. Control voltage (24 VAC) goes through the "Master Off" (normally closed) switch and supplies voltage to the "Master On" (normally open) switch. When the "Master On" switch is momentarily engaged, the master control relay (MCR) engages. This closes the MCR-A contactor (which is in parallel with the "Master On" switch) which will keep the MCR enabled. If the power is interrupted or the "Master Off" switch is pressed the MCR will disengage. The MCR-B contactor supplies power to the rest of the 24 VAC circuits.

For dryers manufactured with Automatic Doors - the purpose of the supply air is to relieve pressure on the automatic door pistons when an emergency stop is engaged.

5) Safety Circuits

The following circuit branches are to verify various safeties, if **ALL** conditions are met ...

a) The first two (2) items are the Auxiliary Contact located on the blower (squirrel cage fan) motor and the Tumbler (basket) Motor Overload. If either of these devices trip, it will open up the safety circuit thereby preventing the dryer from operating.

b) Dryer Level Switches circuit branch ...

(1) On 1-way tilt models, this switch is in series with the dry enable.

(2) On 2-way tilt models ...one (1) pole of each of the two (2) level switches (LS1-A and LS2-A) are in series with the dryer level relay and the other pole is in series with the opposite piston. **IF THE OPPOSITE SIDE IS NOT LEVEL, THE DRYER WILL NOT TILT.**

c) Front Doors Closed circuit branch.

There are two (2) magnetic proximity switches mounted in the door closed position and a magnet mounted on top of the doors. When this magnet aligns with the proximity switch, the contacts in the proximity switch close. When both doors are closed, the front doors closed relay (CR2) turns on.

- (1) There are two (2) sets of contacts in the relay...one (1) set of contacts are in the dry enable circuit branch and the other set go to the PLC (Programmable Logic Controller) input front doors closed.

d) Lint Drawer Closed circuit branch ...

The lint drawer closed switch is located in the front of the dryer. When the lint drawer is closed, it closes the switch contacts, powering the lint drawer closed relay. Then, the dry enable relay will close, supplying 24 VAC to the Phase 5 microprocessor (computer) door signal. This sequence will occur only if the following conditions are met;

- (1) Blower (impellor/fan) Motor Overload is not tripped.
- (2) Drive (tumbler/basket) Motor Overload is not tripped.
- (3) Dryer is level.
- (4) Lint Drawer is closed.
- (5) Doors are closed.

b. Phase 5 Microprocessor Controller (computer)

- 1) The Phase 5 Microprocessor Controller (computer) is powered by 240 VAC on **Pin #7 and Pin #13**. A jumper wire on **Pin #1 to Pin #11** is required to configure the Phase 5 microprocessor (computer) for 240 VAC. The temperature sensor probe is a bullet shaped device that is located above the lint basket. This temperature probe is used to sense the temperature in the exhaust of the dryer. The temperature sensor is a two (2) terminal monolithic integrated circuit temperature transducer that provides an output current proportional to absolute temperature. The transducer acts as a high impedance temperature dependant current source of 1mA/°K. The typical accuracy of this probe is +/- 2.7° F (+/- 1.5° C). In a case where the temperature reaches 220° F (104° C), the Phase 5 microprocessor (computer) will shut down and the L.E.D. (light emitting diode) will display "Hot." To restart a cycle the "CLEAR/STOP" button **must first be** pressed.

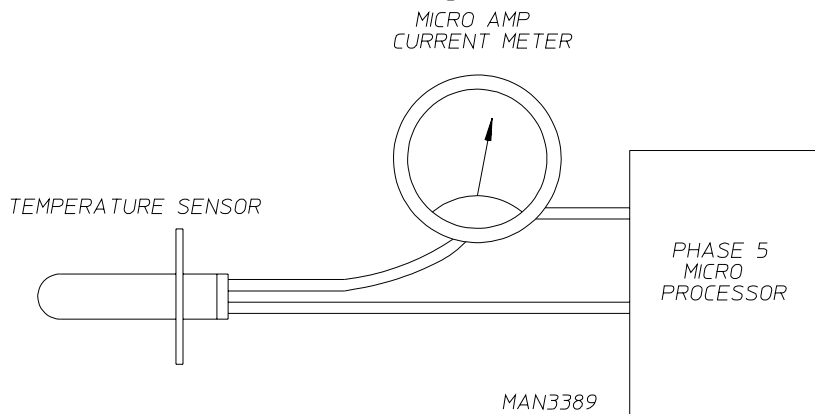

$$^{\circ}\text{F} = \frac{9}{5} (^{\circ}\text{C} + 32)$$

$$^{\circ}\text{C} = \frac{5}{9} (^{\circ}\text{F} - 32)$$

$$\text{TEMPERATURE SENSOR CURRENT} = \frac{^{\circ}\text{C} + ^{\circ}\text{K} (273.15)}{1,000,000} = \text{MICROAMPERES } (\mu\text{A})$$

- 2) The Rotational Sensor is a magnetic proximity switch that is mounted on the side of the right hand 11-inch drive wheels. There is a magnet mounted to the side of the wheel hub. After each rotation of the wheel, the magnet passes by the proximity switch causing the contacts to close and pulse the Phase 5 microprocessor controller (computer). Whenever the magnet is over the proximity switch there **should be** contact closure.
- 3) There is an auxiliary keypad (touchpad) input to the Phase 5 microprocessor controller (computer).

A short between **Pin #1 to Pin #5** of the 6-pin connector is like a "CLEAR/STOP" function on the keypad (touchpad). The PLC (Programmable Logic Controller) will trigger a *clear stop* whenever the dryer is in an **unsafe operating mode**, then disable the dryer's Phase 5 microprocessor (computer) from running a drying cycle.

a) Other functions of the 6-pin connector are as follows:

- (1) A connection of **Pin #1 to Pin #2** will run "A" Cycle.
- (2) A connection of **Pin #1 to Pin #3** will run "B" Cycle.
- (3) A connection of **Pin #1 to Pin #6** will run "C" Cycle.

b) When a drying cycle is started, the blower (fan and impellor) output (**Pin #5**) switches on putting 24 VAC on the blower (fan and impellor) contactor coil, which in turn pulls in the contactor starting the blower motor turning. Through the contactor relay this also triggers an input signal to the PLC (Programmable Logic Controller) disabling the tilting function. Moments later, the tumbler (basket and drum) begins to rotate because the output on **Pin #3** turns on thereby pulling in the tumbler (basket and drum) forward contactor. Next, the Heat "On/Off" (**Pin #4**) will turn on if there is a call for heat, supplying 24 VAC to the heat circuit through the safety circuits.

- (1) The first safety circuit is the Exhaust Hi-Limit which is located on the bracket above the lint basket with the temperature sensor. On a temperature rise of 225° F or higher, the thermal switch opens breaking the heat circuit.
- (2) A second safety circuit is the Burner Hi-Limit Switch located on the side of the burner. On a temperature rise of 330° F or higher, the thermal switch opens breaking the heat circuit, this switch **must be** manually reset on models manufactured as of May 26, 1998.
- (3) A third safety circuit is the Sail Switch which is attached to the front of the burner box. This device pulls in when the impellor (fan and blower) is operating correctly and verifies proper air flow.

If **ALL** the safeties are properly maintained, 24 VAC will enable the Direct Spark Ignition (DSI) Module and a try for ignition begins. The DSI module induces a spark (at the spark electrode) and then opens (energizes) the gas valve for 8-seconds attempting to light the burner. If after 8-seconds the burner does not light, the DSI module will go into a "LOCK-OUT" Mode (the gas valve will be de-energized and the spark will be removed from the ignitor) and will not try to light the burner again until power is again cycled to the DSI module. If the spark produces a flame then a microamp signal is monitored between the flame probe and ground which in turn will keep the burner on. The Heat "On" or "Off" (**Pin #4** of the Phase 5 microprocessor controller [computer]) cycles the heat unless there is a fault at a safety sensor. At the end of a cycle the air jet turns on to clean off the impellor (fan and blower), which turns on **Contact Relay #4**, thereby signaling an input to the PLC (Programmable Logic Controller) that the cycle is complete which then turns on a PLC output relay to turn on the "END OF CYCLE" (E.O.C.) light.

b. PLC (Programmable Logic Controller)

- 1) The PLC (Programmable Logic Controller) can consist of one (1) or two (2) modules; a main module and in some cases an expansion module is used for additional inputs and outputs.

NOTE: The information listed below is generic in nature, refer to blueprints for specific details.

- a) The main PLC (Programmable Logic Controller) module has eight (8) input relays which are labeled #0 through #7 and six (6) output relays labeled #200 through #205.

(1) Input Relays

Input relays #0, #1, #2, and #3 are set up as users inputs to signal what specific function is to be performed (i.e., open-close door, load-unload tilted, open doors, and level dryer). These input relays are charted as 1 and 0 (***1 is logic on and 0 is logic off***). When either an input relay or an output relay in on, the appropriate L.E.D. (light emitting diode) on the PLC will be illuminated.

For input relay #4 to turn on, the left and right front doors **must be** completely open. Once these doors are completely open, the jog forward (input #5) and jog reverse (input #6) can turn on through the PLC which in turn rotates the tumbler (drum and basket) through either output relay #204 or output relay #205 providing the lint door is closed. This interlock is performed through PLC input #16 (lint door closed), or in some cases contactor B is used to interrupt the 24 VAC signal from reaching the drive contactors and the tilting solenoids. Rear door open (input relay #7) is used on 2 door dryer models to verify rear door status.

(2) Output Relays

Output relay #200 controls the open front door function. When this signal is energized, the pneumatic valve opens allowing air into the two (2) door cable cylinders, which in turn opens the front doors.

Output relay #201 controls the open rear door function.

The end of cycle (E.O.C.) - output relay #202 - switches on after an air jet signal is received. This output relay will stay illuminated until the dryer is attended to.

Output relay #203 is used to signal a heater fault.

Output relay #204 (drive forward) and output relay #205 (drive reverse) are used to perform jog functions.

- b) The expansion PLC (Programmable Logic Controller) module has eight (8) inputs which are labeled #10 through #17 and an six (6) output relays labeled #210 through #215.

(1) Input Relays

A fan on or off signal (input #10) determines if the dryer is operating. If the dryer is operating, the door function and tilt function shut down.

Input #11 is the heater fault reset. When the dryer is in a heater fault, an input (at input #11) will reset the fault.

Input #12 is the heat on status. It is used to monitor the Phase 5 microprocessor controller (computer) heat output. Input #12 in conjunction with input #13 (gas valve status), the PLC (Programmable Logic Controller) will monitor for a heater fault condition.

Input #14 indicates that the drying cycle is done (air jet signal). Once the output relay of the Phase 5 microprocessor controller (computer) turns on contact relay #4, input #14 is turned on. This in turn signals the PLC to illuminate the "END OF CYCLE" (E.O.C.) L.E.D. (light emitting diode) until the dryer is attended to.

Front door closed (input #15) is a safety circuit used to lock out the Phase 5 microprocessor controller (computer) from a drying cycle unless the doors are closed.

Lint door closed (input #16) monitors/verifies that the lint door is closed.

The front down/rear down/dryer level (input #17) is another safety device used so that a drying cycle **cannot** be initiated unless the dryer is in the level position.

(2) Output Relays

Output relay #210 controls the air supply to the top of the pneumatic piston to tilt the front of the dryer down.

Output relay #211 controls the air supply to the bottom of the pneumatic pistons to tilt the front of the dryer up, provided that the rear of the dryer is in the level position.

Output relay #212 is used to turn on the fan and cool the load after a heater fault.

Output relay #213 controls the air supply to the top of the pneumatic pistons to tilt the rear of the dryer down.

Output relay #214 controls the air supply to the bottom of the pneumatic pistons to tilt the rear of the dryer. Rear up (output relay #214) applies power to the S6 rear up solenoid through the front down level switch (LS1B).

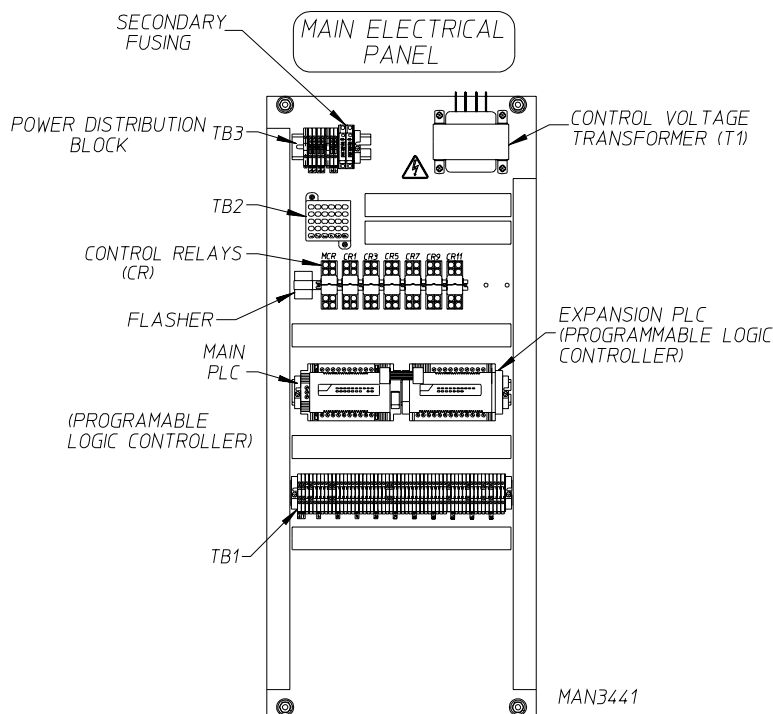

The dryer "CLEAR/STOP" output (relay #215) is used to lock out the Phase 5 microprocessor (computer) from running a drying cycle. If the PLC (Programmable Logic Controller) has input #4 (front door open) and input #10 (blower [squirrel cage fan] on), or input #7 (lint door closed), input #15 (front door closed), or input #17 (dryer level) are off, then the PLC will close output relay #215 (dryer "CLEAR/STOP") so that a drying cycle **cannot** be initiated.

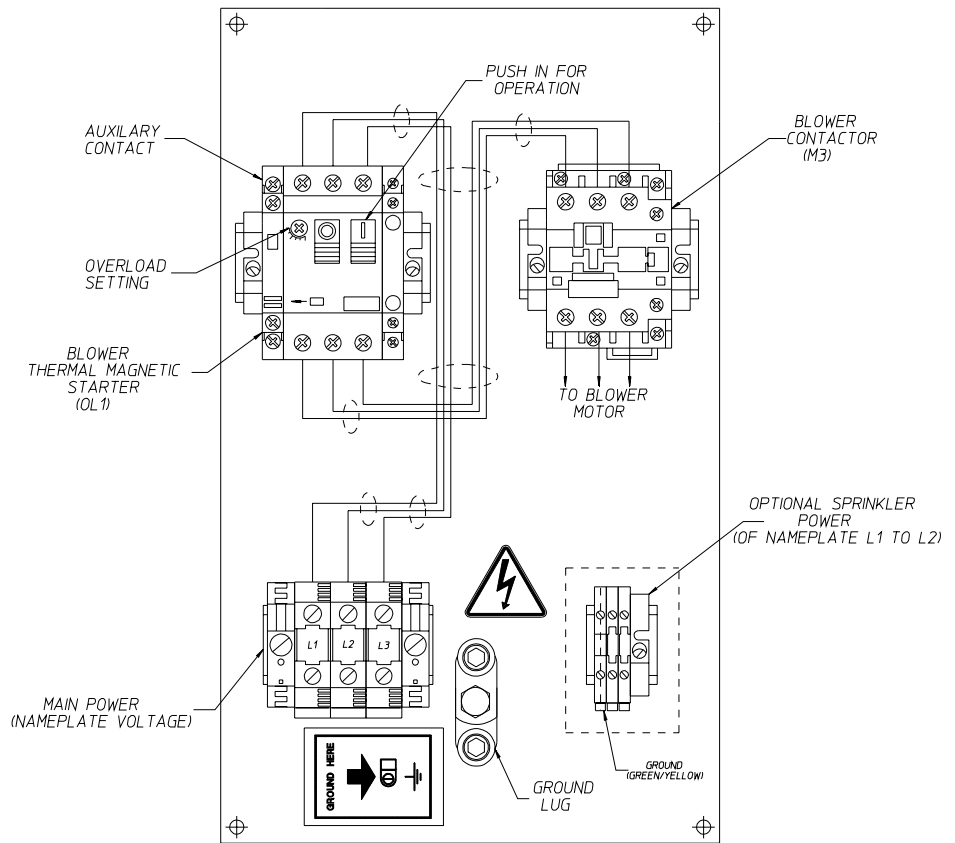
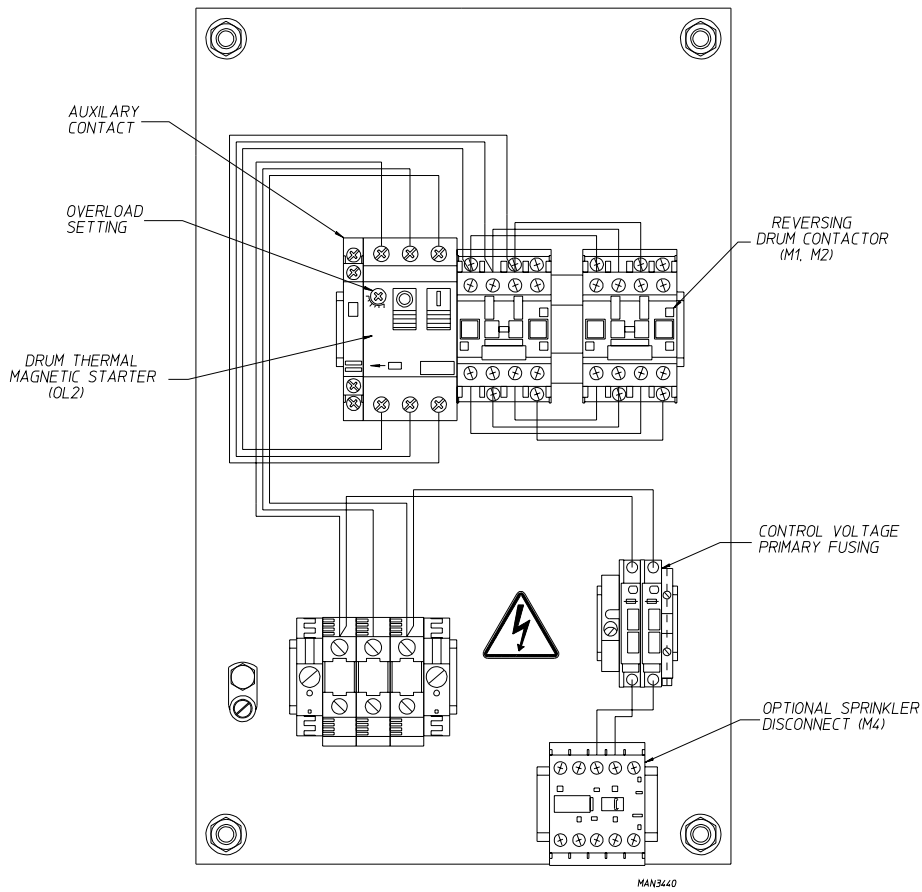

BASE ELECTRICAL PANEL

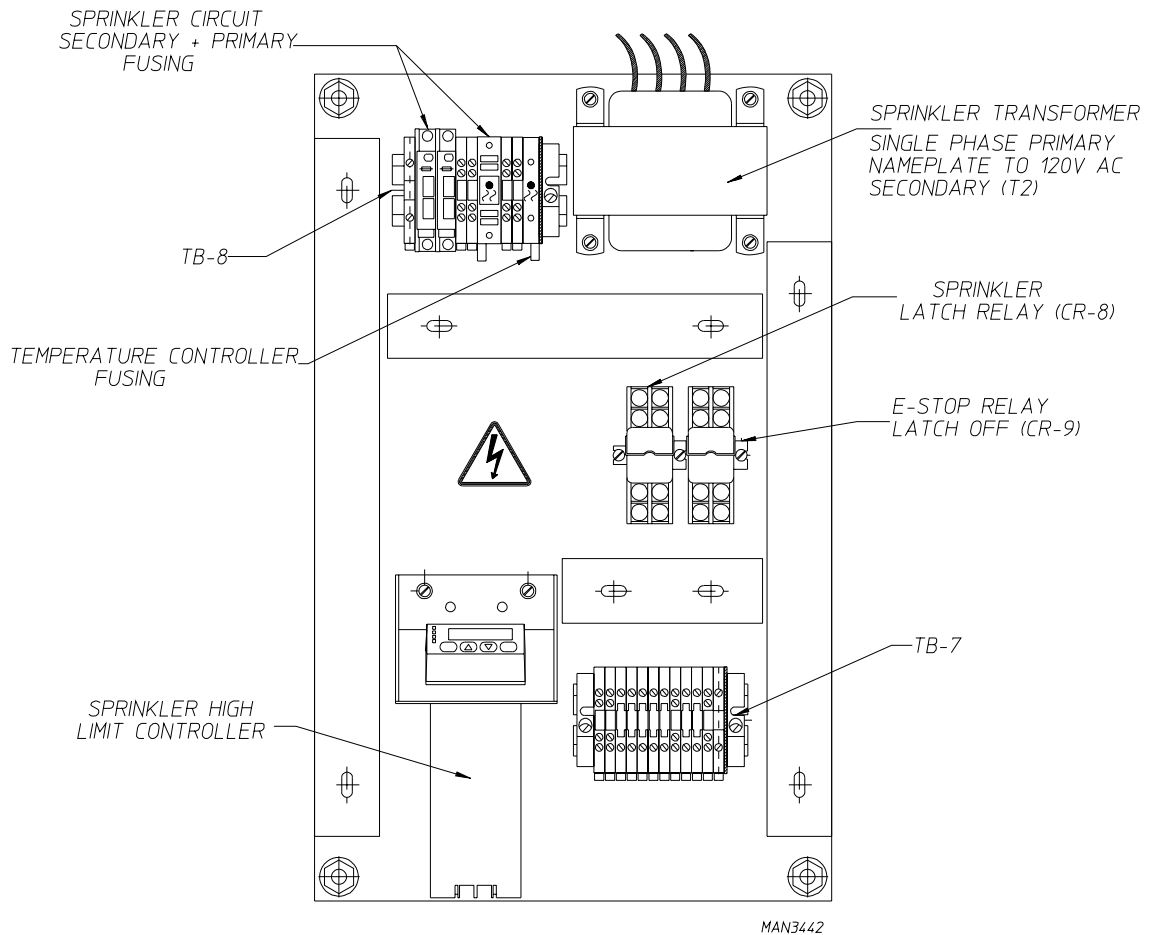

2. Electrical Component Replacement

a. Control Voltage Transformer (refer to the **illustration** on **page 92**) Replacement

- 1) Discontinue electrical service to the dryer.
- 2) Locate the correct schematic for the specific change(s) required and verify the wiring of the transformer using the schematic.
- 3) Verify the voltage of the new transformer.
- 4) Loosen and then remove the four (4) wires for a 208-230/240 VAC dryer or the six (6) wires for a 380 VAC (and higher) dryer from terminal block #3 (TB3).
- 5) Remove the four (4) screws securing the transformer, then remove the transformer itself.
- 6) To install new transformer reverse above procedure.
- 7) Reestablish electrical service to the dryer.

b. PLC (Programmable Logic Controller) Replacement

- 1) Discontinue electrical service to the dryer.

If there is an expansion module along side the main module carefully disconnect the ribbon cable connecting the two (2) units together.

- 2) Mark and identify the wires that will be removed for proper reinstallation.
- 3) To remove the Programmable Logic Controller (PLC) from the mounting rail, using a screwdriver, very carefully pull out the mounting clip on the bottom of the PLC and lift the unit out of the rail.

- 4) To replace the Programmable Logic Controller (PLC), push in the top of the PLC into the rail and then snap in the bottom of the unit.

- 5) Replace the wires removed in **Step #2**.

If there was an expansion module along side the main module carefully reconnect the ribbon cable.

- 6) Reestablish electrical service to the dryer.

c. Relay Replacement

- 1) Discontinue electrical service to the dryer.
- 2) Remove hold down spring.
- 3) Remove relay from relay socket.
- 4) To install new relay, reverse above procedure.

d. Phase 5 Microprocessor Controller (computer) Replacement

- 1) Discontinue electrical service to the dryer.
- 2) Carefully unplug the 15-pin connector, the 6-pin connector, and the keypad (touchpad) connector.
- 3) Disconnect the "GRD" connector and the air jet spade connector.

Disconnect *optional* Battery backup (if applicable).

- 4) Loosen and remove the two (2) screws securing the Phase 5 microprocessor (computer) and then remove the computer from the door.
- 5) To install new Phase 5 microprocessor (computer), reverse above procedure.

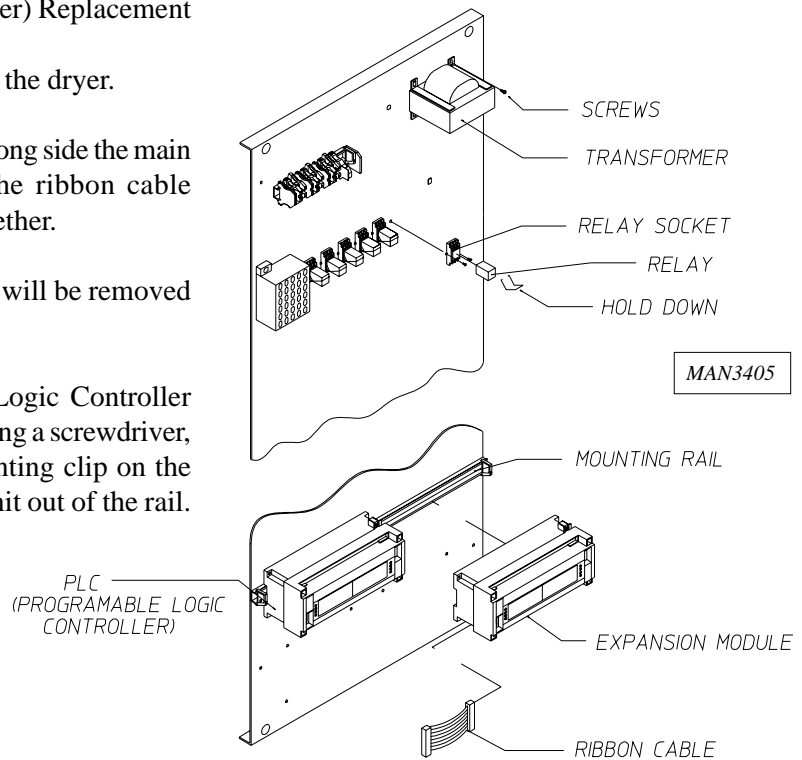

e. Keypad (touchpad) Replacement

- 1) Discontinue electrical service to the dryer.
- 2) Peel existing keypad (touchpad) from the door.
- 3) Remove as much of the remaining adhesive (from the removed keypad [touchpad] as possible.
- 4) Install and adhere new keypad (touchpad).
- 5) Reestablish electrical service to the dryer.

f. Switch Replacement

- 1) Discontinue electrical service to the dryer.
- 2) Mark and identify the wires that will be removed for proper reinstallation.
- 3) Remove wires.
- 4) To remove a contact block, loosen and remove the mounting screw.

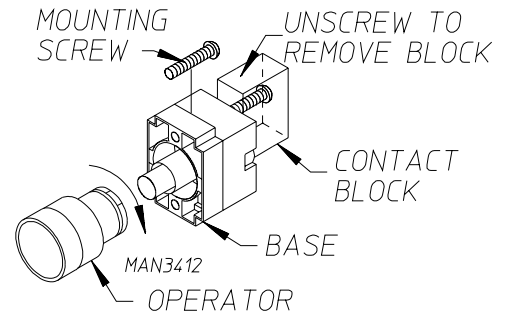

NOTE: Contact Block #1 and Contact Block #2 is normally closed (N.C.) while Contact Block #3 and Contact Block #4 is normally open (N.O.).

- 5) To remove or replace operator, loosen the two (2) screws that hold the switch body away from the door.
- 6) Quarter turn the operator (in the direction shown in the above illustration) and remove.
- 7) Reinstall the wires removed in **Step #3**.
- 8) Reestablish electrical service to the dryer.

g. Switch Bulb Replacement

- 1) Discontinue electrical service to the dryer.
- 2) Unscrew clear lens shield.
- 3) Unscrew colored lens.
- 4) Remove diffuser.
- 5) With finger tip, gently push and turn the bulb to unlock.

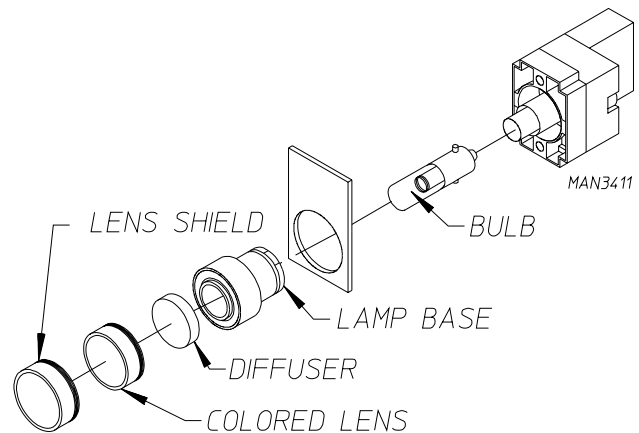

NOTE: A piece of tubing with an inside diameter the size of bulb may assist in bulb removal and replacement.

- 6) To install new bulb, reverse **Step #5 through Step #1**.

h. End of Cycle Light Replacement

- 1) Discontinue electrical service to the dryer.
- 2) Loosen and remove the cap screw on the top of the cap.
- 3) Remove the cap.
- 4) Loosen and remove the screw going into the lens.
- 5) Twist out lens and remove bulb/light.
- 6) To install new bulb, reverse above procedure

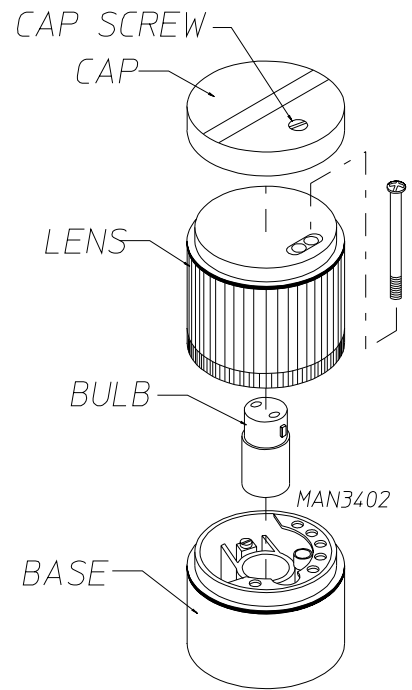

i. Tilt Switch Replacement

- 1) Discontinue electrical service to the dryer.
- 2) Remove the base panel from the left hand side of the dryer.

CAUTION: DO NOT PLACE HANDS BETWEEN THE DRYER BASE AND THE TUMBLER (Basket/Drum) SECTION. SERIOUS INJURY CAN RESULT.

- 3) Unscrew tilt switch.
- 4) Loosen and remove the two (2) screws securing the junction cover.
- 5) Remove the junction cover.
- 6) Loosen and remove the two (2) mounting screws.
- 7) Loosen and remove cord grip cap.
- 8) Remove cord grip.
- 9) Place pivot arm in the 1 o'clock position for the front tilt switch and in the 11 o'clock position for the rear tilt switch

Verify that the body orientation and the head orientation are correct.

*Verify that the tilt switch arm is **not** in the vertical position or damage will result.*

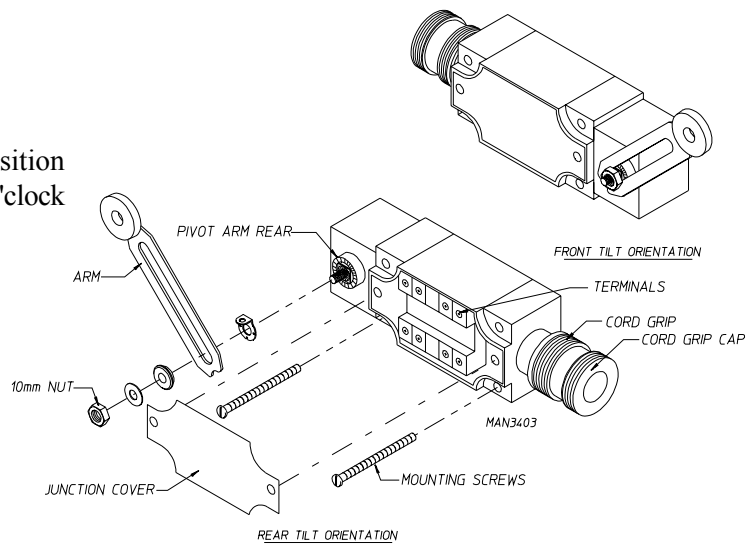

- 10) Holding the tilt arm, tighten up (snug up) on the nut.
 - 11) Hold pivot point with a screwdriver and tighten the nut.
 - 12) Replace base panel.
 - 13) Reestablish power to the dryer.
- j. Tilt Switch Adjustment
- 1) Discontinue electrical service to the dryer.
 - 2) Remove the base panel from the left hand side of the dryer.

CAUTION: *DO NOT* PLACE HANDS BETWEEN THE DRYER BASE AND TUMBLER (Basket) SECTION. SERIOUS INJURY CAN RESULT.

- 3) To adjust the pivot arm; hold the arm and with a #10 metric wrench and loosen the nut.
- 4) Place pivot arm in the one o'clock position for the front tilt switch and in the 11 o'clock position for the rear tilt switch.

*Verify that the tilt switch arm is **not** in the vertical position or damage will result.*

- 5) Holding the tilt arm, tighten up (snug up) on the nut.
- 6) Hold pivot point with a screwdriver and tighten the nut.
- 7) Replace base panel.
- 8) Reestablish electrical service to the dryer.

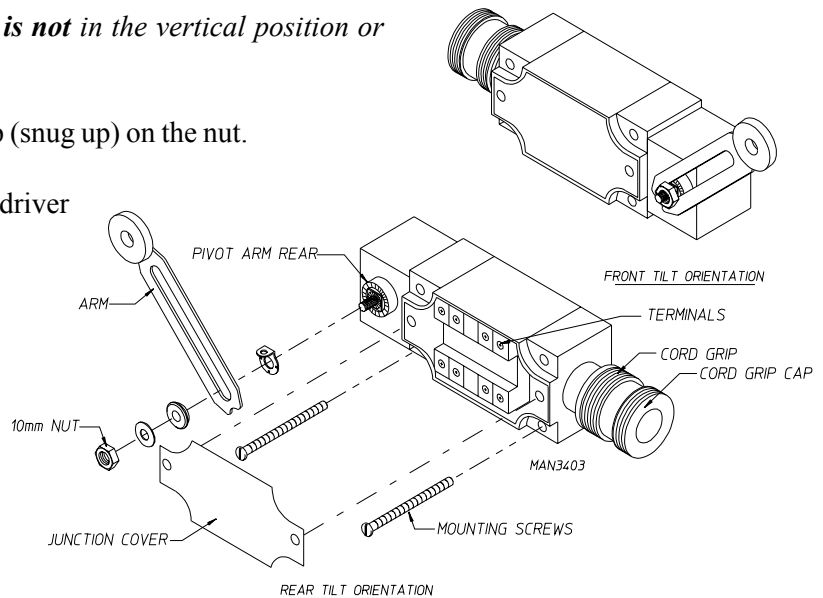

L. TUMBLER (Basket) SYSTEM

1. Tumbler Drive System

The tumbler (basket) is supported and driven by four (4) 11-inch diameter drive wheel assemblies. Two (2) of these wheels are attached to a 1-1/2" diameter idler shaft, while the other two (2) are attached to a 1-1/2" diameter drive shaft. Each of the wheels is fastened to the shafts by a tranorque keyless locking bushing. The tranorque is made up of three (3) pieces; an inner collar, an outer sleeve, and a locking nut. The inner and outer elements have matching opposing tapers. As a result, when the nut is tightened, the tranorque contracts onto the shaft and expands into the drive wheel hub locking the wheel on to the shaft. No key is required.

The idler shaft and drive shaft are each supported by two (2) 1-1/2" diameter pillow block bearings. These bearings sit on slotted support channels and can be moved inward or outward by the adjustment bolts. This results in raising or lowering the tumbler (basket).

The drive system consists of a shaft mounted gear reducer, two (2) V-belts, and a 5 HP drive motor. Belt tension can be adjusted by tightening or loosening the gear reducer turnbuckle.

To keep the tumbler (basket) in the middle of the dryer a series of retaining wheels are used in the front and rear of the dryer. The retaining wheels run along the vertical edge of the tumbler (basket) rings. These keep the tumbler from rubbing on the front and rear panels of the dryer.

TUMBLER DRIVE SYSTEM

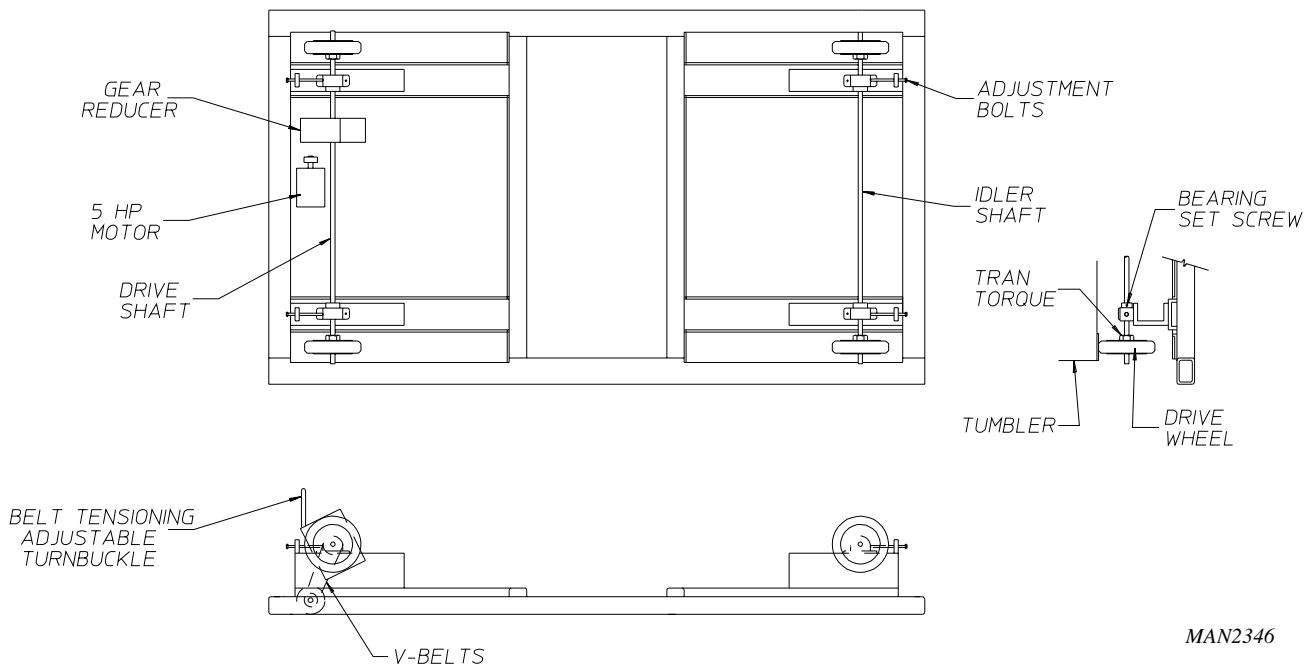

MAN2346

WHEN REPLACING A DRIVE WHEEL:

1. ALWAYS CHANGE BOTH WHEELS ON A SHAFT.
2. MARK POSITION OF BEARINGS ON SUPPORTS. THIS WILL MAKE REASSEMBLY OF SHAFT AND CENTERING OF TUMBLER EASIER.
3. SHOVE BLOCKS OF WOOD UNDER TUMBLER TO TAKE IT'S WEIGHT OFF OF DRIVE WHEELS.
4. REMOVE BEARING HOLD DOWN BOLTS AND ADJUSTMENT BOLTS.
5. SLIDE COMPLETE SHAFT ASSEMBLY OUT OF SIDE OF DRYER.

WARNING: TO ENSURE THAT THE DRIVE IS NOT UNEXPECTEDLY STARTED, TURN OFF and LOCK OUT and/or TAG POWER SOURCE BEFORE PROCEEDING. FAILURE TO OBSERVE THESE PRECAUTIONS COULD RESULT IN PERSONAL INJURY.

WARNING: Drive shaft assembly is heavy. **IMPROPER HANDLING CAN CAUSE PERSONAL INJURY.**

2. Drive Motor Components

a) Drive Motor Replacement

- 1) Discontinue electrical service to the dryer.
- 2) Mark and identify the wires that will be removed for proper reinstallation.
- 3) Loosen the turnbuckle and remove V-belts.
- 4) Mark the inside of the shaft before removing the taper bushing (for proper reinstallation).
- 5) Remove the taper bushing and motor pulley.

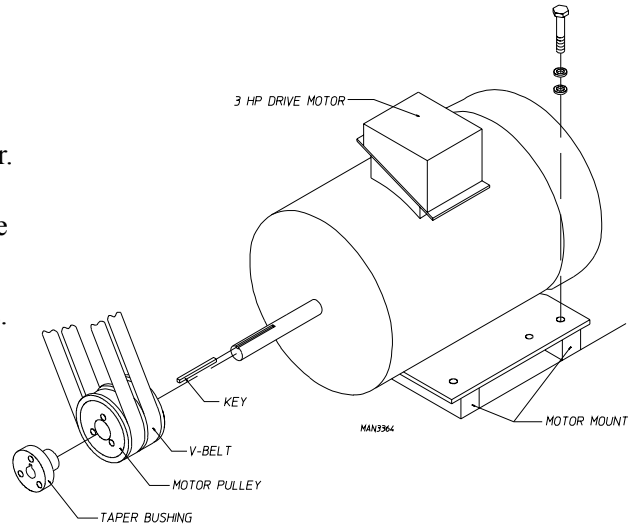

Refer to **Taper Bushing and Motor Pulley Replacement (Step #3 through Step #6)** on **page 98**.

- 6) Remove the bolts securing the motor to the motor mount.
- 7) Install new motor and secure to motor mount.
- 8) Reinstall motor pulley and taper bushing.

Refer to **Taper Bushing and Motor Pulley Replacement (Step #7 through Step #12)** on **page 98**.

- 9) Reinstall V-belts then tighten turnbuckle.

IMPORTANT: DO NOT OVER TIGHTEN TURNBUCKLE.

- 10) Rewire the new drive motor in the same order as the wiring from the motor that was removed.

Diagram is usually affixed to the side of the motor.

- 11) Reestablish electrical service to the dryer.

b) V-Belt Replacement

- 1) Discontinue electrical service to the dryer.
- 2) Loosen turnbuckle and remove V-belts.

- 3) Install new V-belts.

NOTE: Replace V-belts in matched sets (both belts).

- 4) Tighten turnbuckle.

IMPORTANT: *DO NOT* OVER TIGHTEN TURNBUCKLE.

- 5) Reestablish electrical service to the dryer.

3) Taper Bushing Assembly and Drive Motor Pulley Assembly Components

a) Taper Bushing and Drive Motor Pulley Replacement

- 1) Discontinue electrical service to the dryer.
- 2) Loosen turnbuckle and remove V-belts.
- 3) Mark inside of the drive motor shaft.
- 4) Remove the bolts securing the taper bushing.
- 5) Insert bolts into the threaded holes on the motor pulley and tighten evenly for pulley removal.
- 6) Loosen the set screws on the taper bushing and remove the bushing.
- 7) Measure the mark on the drive motor shaft to the end of the shaft.
- 8) Install the new drive motor pulley.
- 9) Align the new taper bushing with the mark on the shaft and install by tightening the set screws.
- 10) Insert bolts into the holes on the taper bushing and thread in to the motor pulley and tighten evenly.
- 11) Check that the pulley is in proper alignment.
- 12) Reinstall V-belts and tighten turnbuckle.

IMPORTANT: *DO NOT* OVER TIGHTEN TURNBUCKLE.

- 13) Reestablish electrical service to the dryer.

4. Drive Shaft Assembly Components

a) Drive Shaft Replacement

- 1) Discontinue electrical service to the dryer.
- 2) Remove the side panel and guard from the dryer covering the drive wheels
- 3) Mark the position of the pillow block bearing on the mounting pad and loosen the set screws.

- 4) Insert blocks of wood under the tumbler (basket) - access through the lint drawer - to take the weight off of the drive wheels.
- 5) Loosen the turnbuckle and remove the V-belts.

Remove bottom turnbuckle mounting bolt.

- 6) Remove the trantorque from the drive wheels. (A chain wrench will be required to hold the drive shaft to remove the trantorque.)

IMPORTANT: On reinstallation, the trantorque *must be* torqued to 2,300 foot-pounds (259 n-m (newton-meters)).

- 7) Remove the bolts from the pillow block bearing mounting pads as well as the adjustment bolts.
- 8) Slide the pillow block bearings and trantorque inward towards the gear reducer on the drive shaft.
- 9) Lift the end of the drive shaft closest to the rear of the dryer and pivot the other end of the shaft on the drive wheel until the shaft can be removed from the dryer.

- 10) Remove the drive wheel.

- 11) *Carefully* file the score marks on the drive shaft from the set screws before removing the pillow block bearings.

- 12) Remove the pillow block bearings.

- 13) For gear reducer removal, refer to **Section D** on **page 100** and **page 101**.

- 14) To install new drive shaft, reverse **Step #13 through Step #2**.

- 15) Reestablish electrical service to the dryer.

b) Drive Wheel Replacement

- 1) Discontinue electrical service to the dryer.
- 2) Follow **Step #2 through Step #10** in the **Drive Shaft Replacement** instructions in the previous section (**page 98** and **page 99**).

IMPORTANT: Both drive wheels *should be* replaced on the drive shaft.

- 3) To install new drive wheels, reverse **Step #10 through Step #2** in the **Drive Shaft Replacement** instructions in the previous section (**page 99** and **page 98**).

- 4) Reestablish electrical service to the dryer.

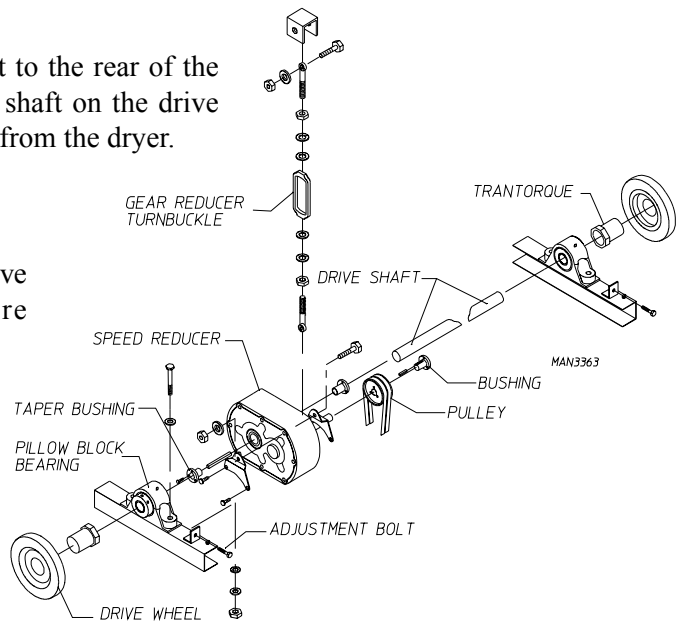

c) Pillow Block Bearing(s) Replacement

- 1) Discontinue electrical service to the dryer.
- 2) Follow ***Step #2 through Step #9*** in the instructions on **page 98 and page 99**.
- 3) Remove both drive wheels and trantorques.
- 4) Carefully file the score marks on the drive shaft from the set screws before removing the pillow block bearing(s).
- 5) To install the new pillow block bearing(s), reverse procedure in the instructions on **page 99 and page 98**.
- 6) Reestablish electrical service to the dryer.

d) Gear (Speed) Reducer Replacement

CAUTION: Replacement gear reducers are shipped without oil. Add proper amount (1.4 liters) of recommended lubricant before operating. **FAILURE TO OBSERVE THESE PRECAUTIONS WILL RESULT IN DAMAGE TO THE DRYER and WILL VOID THE WARRANTY.**

CAUTION: Too much oil will cause overheating and too little oil will result in gear failure. Check oil level regularly. **FAILURE TO OBSERVE THESE PRECAUTIONS COULD RESULT IN DAMAGE TO THE DRYER and WILL VOID THE WARRANTY.**

- 1) Discontinue electrical service to the dryer.
- 2) Measure the distance of the gear (speed) reducer from the rear of the dryer to assist in positioning the gear reducer on the drive shaft during reinstallation.
- 3) Follow ***Step #2 through Step #9*** in the instructions on **page 98 and page 99**.
- 4) Remove the trantorque and pillow block bearing from the drive shaft closest to the rear of the dryer.
- 5) Remove the three (3) bolts from the taper bushing and insert two (2) of these bolts into the threaded holes and tighten evenly to remove the taper bushing from the gear reducer.
- 6) Repeat ***Step #5*** to remove the other taper bushing from the gear reducer.
- 7) Remove the gear (speed) reducer from the drive shaft.
- 8) Check the position of the drain plug and the breather plug.
- 9) Check the turnbuckle mount pad on the gear reducer for the correct application.
- 10) Install the new gear (speed) reducer on the drive shaft long with the taper bushing, the pillow block bearing (set screws in the pillow block bearing face the end of the drive shaft), the trantorque, and the drive wheels.

- 11) Reinstall the drive shaft into the dryer.
- 12) Secure the gear reducer to the drive shaft by reinstalling the three (3) bolts into the taper bushing and tighten evenly for proper mounting.
- 13) Repeat **Step #12** to reinstall the other taper bushing.
- 14) Reinstall the bolt into the turnbuckle and mounting bracket.
- 15) Reinstall V-belts and tighten turnbuckle.
- 16) Prior to operating new gear (speed) reducer, fill with 1.4 liters of SAE 90 gear oil.

IMPORTANT: *DO NOT* OVER TIGHTEN TURNBUCKLE.

- 17) Mount the pillow block bearings onto the mounting pads (using the bolts that were removed)... *do not tighten.*
- 18) Tighten the trantorque into the drive wheels.
- 19) Tighten the adjustment bolts until the tumbler (basket) is centered.

IMPORTANT: Remove the wooden blocks that were inserted under the tumbler (basket).

- 20) Tighten the bolts on the pillow block bearings.

NOTE: Verify correct mounting position of the gear reducer. Make the necessary corrections and/or adjustments to the gear reducer for proper mounting. Changing the drain plug, breather plug, as well as the turnbuckle mounting pad may be required.

NOTE: Inspect **ALL** of the work performed checking for security of parts and proper alignment.

- 21) Reestablish electrical service to the dryer.

5. Retaining Wheel Components

a) Retaining Wheel Cover Panel Removal

- 1) Discontinue electrical service to the dryer.
- 2) Remove the top front panel to access the two (2) front retaining wheels and/or the rear top panel to access the two (2) rear retaining wheels.
- 3) To gain access to the bottom front retaining wheel the bottom panel **must be** removed. (The bolts securing this panel are located behind the right and left control panels.)

NOTE: The lower front retaining wheel *does not* have a cover.

NOTE: The guard panel *must be* removed from the dryer to access the rear bottom panel.

- 4) Remove the bolts from the guard panel to gain access to the rear bottom retaining wheel.

b) Retaining Wheel(s) Replacement

- 1) Discontinue electrical service to the dryer.
- 2) Remove the four (4) Phillips pan head screws to remove the cover.
- 3) Remove the hardware (i.e., bolt, lock washer, and flat washer) from the hex nut and weld nut on the wheel mount.
- 4) Install the new retaining wheel.

Reinstall the lock washer then the flat washer onto the bolt and insert into lower mount hole through the retaining wheel and through the hex nut, then into the weld nut and snug up the bolt.

WARNING: ALL SERVICE and TROUBLESHOOTING **SHOULD BE** PERFORMED BY A QUALIFIED PROFESSIONAL or SERVICE AGENCY.

WARNING: WHILE MAKING ADJUSTMENTS, OBSERVE ALL SAFETY PRECAUTIONS DISPLAYED ON THE DRYER or SPECIFIED IN THIS MANUAL.

- 5) Reinstall cover and screws removed in **Step #2**.

- 6) Reestablish electrical service to the dryer.

c) Retaining Wheel(s) Adjustment

- 1) With the dryer operating, turn off-set hex hub on retaining wheel until wheel is at proper tension.
- 2) Snug nut against off-set hex hub and then tighten.

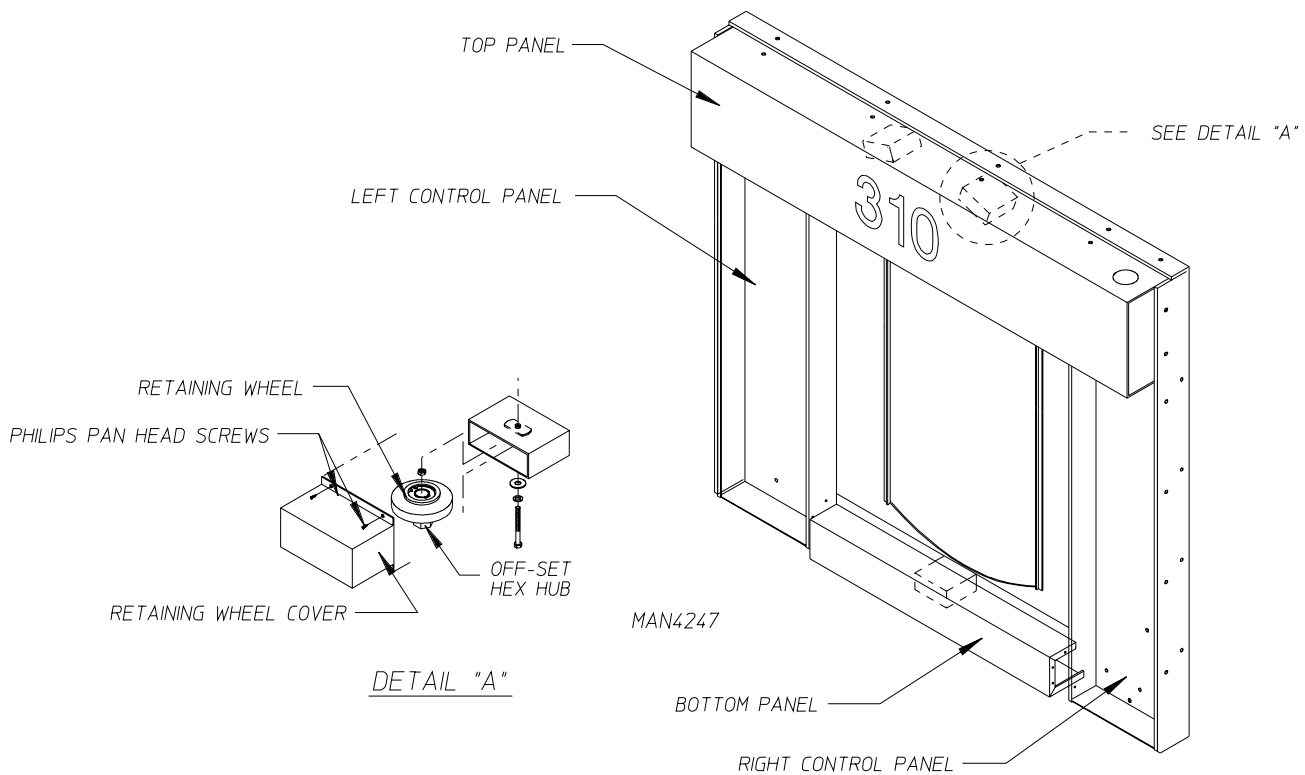

CAUTION: USE EXTREME CARE WHEN SETTING RETAINING WHEEL TENSION. PERSONAL INJURY MAY RESULT.

NOTE: Proper retaining wheel tension has been achieved when the wheel spins and stops when slight pressure is applied (to the retaining wheel itself).

6. Tumbler/Basket Electrical Components

a) Tumbler (Basket) Thermal Magnetic Starter and Auxiliary Contact Block Replacement

- 1) Discontinue electric service to the dryer.
- 2) Mark and identify the wires that will be removed for proper reinstallation.
- 3) Set the control of the thermal magnetic starter to the "stop" position.
- 4) Press down on the thermal magnetic starter and lift the bottom up and out of the din rail.
- 5) Mark and identify the wires that will be removed for proper reinstallation.
- 6) Remove **ALL** associated wires.
- 7) Separate the thermal magnetic starter from the auxiliary contact block.
- 8) Install new thermal magnetic starter or auxiliary contact block.
- 9) Reassemble the thermal magnetic starter to auxiliary contact block.
- 10) Set overload to required setting.

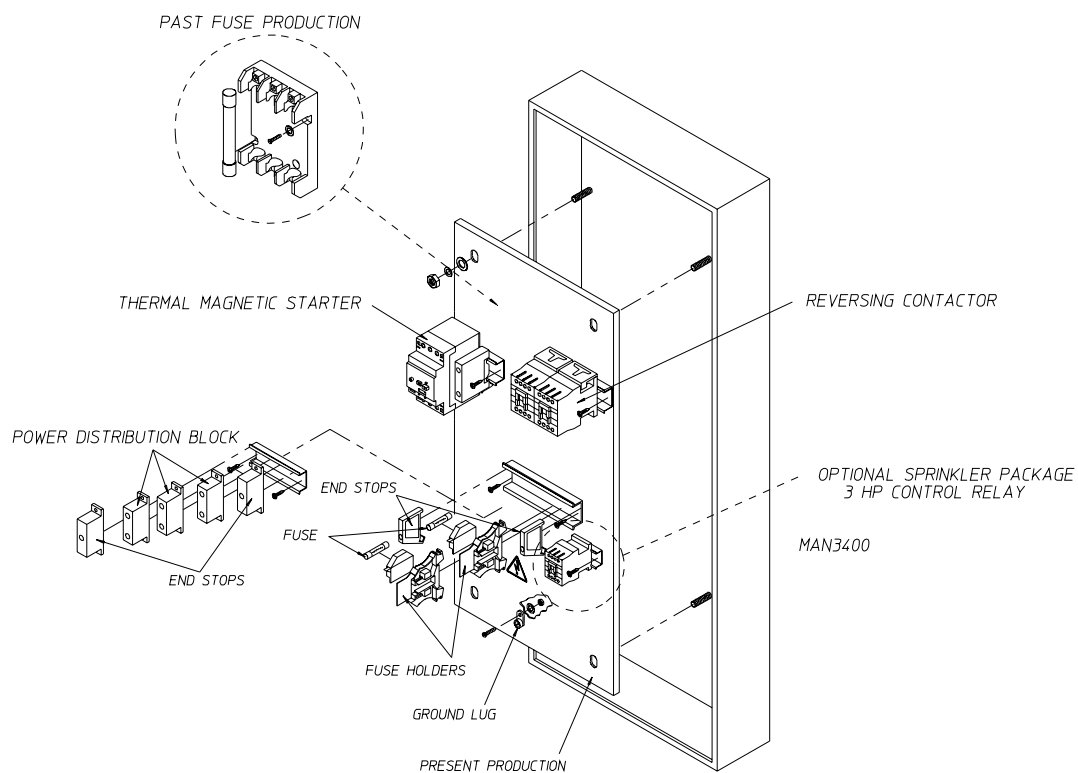

- 11) Replace **ALL** the wires removed in **Step #5** (refer to **previous page [page 91]**).
- 12) Mount the top of the thermal magnetic starter to the top of the din rail and press down and in.
Inspect **ALL** of the work performed.
- 13) Set the control of the thermal magnetic starter to the "start" position.
- 14) Reestablish electrical power to the dryer.

7. Rotational Sensor Assembly

The Rotational Sensor Assembly is located on the right rear drive wheel. It consists of a magnetic rotational switch, mounted on the bracket which is bolted to the pillow block bearing. A magnet is riveted to the drive wheel.

The magnetic rotational sensor switch senses the rotation of the tumbler (basket). If the gap between the sensor switch and the magnet is greater than a preset amount, then the dryer will shut down on "SEFL" ("rotational sensor failure").

a) Rotational Sensor Switch Replacement

- 1) Discontinue electric service to the dryer.
- 2) Remove the adjustment nut closest to the drive wheel.
- 3) Remove the magnetic rotational sensor switch from the mounting bracket.
- 4) Depress the tabs on the rotational sensor harness plug and pull apart, then remove the sensor switch.
- 5) To install a new sensor switch, connect the plug of the new sensor switch to the sensor harness.
- 6) Place one (1) adjustment nut onto the sensor switch and insert into the mounting bracket.
- 7) Place the second adjustment nut on but *do not* tighten.

The magnet on the drive wheel and the sensor switch **must be** in a horizontal line to one another.

- 8) The gap between the magnet and the sensor switch **must be** 1/8-inch (5.71 cm).
- 9) Tighten the adjustment nuts installed in **Step #7 and Step #6**.
- 10) Reestablish electrical service to the dryer.

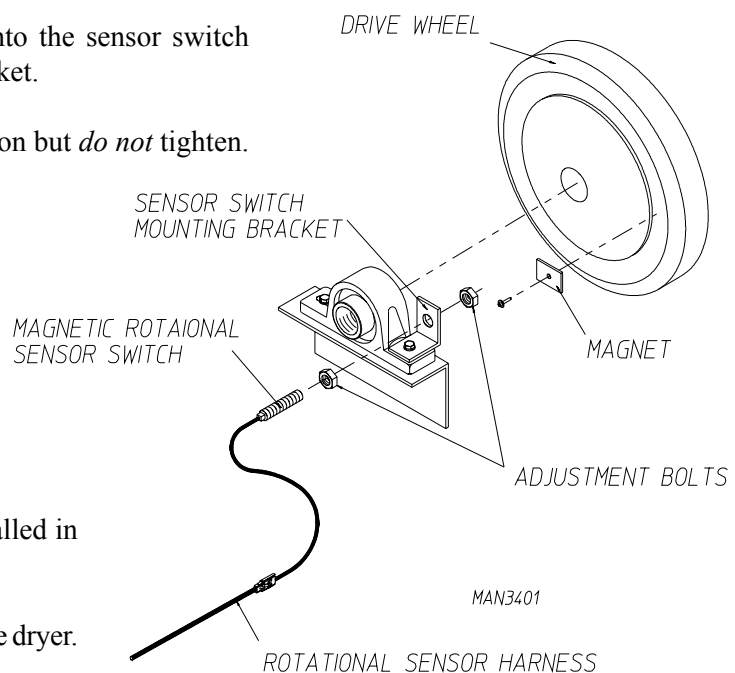

SECTION VI

TROUBLESHOOTING

IMPORTANT: YOU MUST DISCONNECT and LOCKOUT THE ELECTRIC SUPPLY and THE GAS SUPPLY or THE STEAM SUPPLY BEFORE ANY COVERS or GUARDS ARE REMOVED FROM THE MACHINE TO ALLOW ACCESS FOR CLEANING, ADJUSTING, INSTALLATION, or TESTING OF ANY EQUIPMENT per OSHA (Occupational Safety and Health Administration) STANDARDS.

The information provided will help isolate the most probable components associated with the difficulty described. The experienced technician realizes, however, that a loose connection or broken/shorted wire may be at fault where electrical components are concerned... not necessarily the suspect component itself. Electrical parts **should always be** checked for failure before being returned to the factory.

IMPORTANT: When replacing blown fuses, the replacement *must be* of the exact rating as the fuse being replaced. The information provided *should not* be misconstrued as a hand-book for use by an untrained person in making repairs.

WARNING: ALL SERVICE and TROUBLESHOOTING **SHOULD BE PERFORMED BY A QUALIFIED PROFESSIONAL or SERVICE AGENCY.**

WARNING: WHILE MAKING REPAIRS, OBSERVE ALL SAFETY PRECAUTIONS DISPLAYED ON THE DRYER or SPECIFIED IN THIS MANUAL.

A. No Display...

1. “EMERGENCY STOP” button pushed in.
2. Service panel fuses blown or tripped breaker.
3. Blown F1 (fuse 1) or F2 (fuse 2) on right hand control panel.
4. Blown F4 (fuse 4) on right hand control panel.
5. Failed microprocessor controller (computer).
6. Optional sprinkler circuit emergency relay not engaged ...
 - a. Service panel fuse blown or tripped breaker.
 - b. Sprinkler circuit high limit has tripped.

NOTE: SPRINKLER *MUST HAVE* POWER FOR THE DRYER TO OPERATE.

B. Drive motor is not operating (does not start)...

* **Microprocessor controller (computer) relay output indicator (either forward “FWD” or reverse “REV”) is on.**

1. Blown drive motor contactor fuses or overloads.
2. Failed drive motor contactor.
3. Failed drive motor.

* **Microprocessor controller (computer) relay output indicator (neither forward “FWD” or reverse “REV”) is on.**

1. Failed microprocessor controller (computer).

C. Drive motor operates in one direction only... stops and restarts in the same direction...

* **Appropriate microprocessor controller (computer) relay output indicator is on.**

1. Failed reversing contactor (relay).
2. Failed electrical reversing contactor interlock.

* **Appropriate microprocessor controller (computer) relay output indicator is off.**

1. Failed microprocessor controller (computer).

D. Drive motor operates okay for a few minutes and then either repeatedly or occasionally trips the overload protector...

NOTE: When the overload protector trips, the microprocessor controller (computer) L.E.D. (light emitting diode) display will read **“door.”**

1. Motor is overheating ...
 - a. Motor air vents clogged with lint.
 - b. Low voltage to motor.
 - c. Failed motor.
 - d. Tumbler (basket) is binding... check for an obstruction.
 - e. Tumbler bearings are binding.
 - f. V-belts are too tight.
 - g. Dryer has an oversized load.
 - h. Voltage to the dryer is incorrect... check dryer data label for specified voltage.

2. Failed overload protector.

E. Impellor (fan) motor is not operating (does not start)...

*** Microprocessor controller (computer) “MTR” relay output indicator is on.**

1. Blown blower (impellor and fan) motor fuses or overloads.
2. Failed blower (impellor and fan) motor contactor (relay).
3. Failed blower (fan and impellor) motor.
4. Sail switch verification circuit not in open position prior to the start of the drying cycle.

*** Microprocessor controller (computer) “MTR” relay output indicator is off.**

1. Failed microprocessor controller (computer).

F. Blower (fan and impellor) motor operates okay for a few minutes and then either repeatedly or occasionally trips the overload protector..

NOTE: When the overload protector trips, the microprocessor controller (computer) L.E.D. (light emitting diode) display will read “door.”

1. Motor is overheating ...
 - a. Motor air vents clogged with lint.
 - b. Low voltage to motor.
 - c. Failed motor.
 - d. Tumbler (basket) is binding... check for an obstruction.
 - e. Failed gear reducer or tumbler bearing.
 - f. V-belts are too tight.
 - h. Motor is running at incorrect voltage.

2. Failed overload protector.

G. Both drive motor and blower (fan and impellor) motor are not operating... microprocessor controller (computer) L.E.D. (light emitting diode) motor indicator dots and the “MTR” relay output and forward “FWD” or reverse “REV” L.E.D. indicators are on.

1. Blown drive motor and blower (fan and impellor) motor fuses or overloads.
2. Failed motors (both blower [fan and impellor] motor and drive motor).

H. Both drive motor and blower (fan and impellor) motor are not operating...microprocessor controller (computer) L.E.D. (light emitting diode) motor indicator dots and the “door” L.E.D. indicator are on but the relay output L.E.D. indicators are off (microprocessor controller [computer] L.E.D. display *does not* read “door”).

1. Failed microprocessor controller (computer).

I. Microprocessor controller (computer) L.E.D. (light emitting diode) display reads “dSFL” continuously and the buzzer (tone) sounds every thirty (30) seconds...

1. Fault in microprocessor heating sensing circuit ...

a. Failed microprocessor temperature sensor.

b. Blown “dSFL” 1/8-amp fuse on the microprocessor controller (computer).

c. Failed microprocessor controller (computer).

d. Broken wire or connection between the microprocessor controller (computer) and the microprocessor temperature sensor.

J. Microprocessor controller (computer) L.E.D. (light emitting diode) display reads “door” and the microprocessor controller (computer) “DOOR” L.E.D. indicator is off...

1. Fault (open circuit) in main door or lint drawer switch circuit ...

a. Lint drawer not closed all the way.

b. Lint drawer switch is out of proper adjustment.

c. Failed lint drawer switch.

d. One (1) of the main door switches has failed.

e. One (1) of the main door switch contact magnets is either missing or is broken.

f. Failed door switch relay.

g. Broken wire or connection in main door or lint drawer switch circuit.

h. Drive motor or blower (fan and impellor) motor thermal overload reset has tripped.

2. Failed 24 VAC step down transformer.

3. Master control relay (MCR) not engaged.

4. Blown 24 VAC control circuit fuse (fuse 3 [F3]).

K. Microprocessor controller (computer) L.E.D. display reads “door” and the microprocessor controller (computer) “DOOR” L.E.D. (light emitting diode) indicator is on...

1. Failed microprocessor controller (computer).

L. Microprocessor controller (computer) will not accept any keyboard [touchpad] entries, (i.e., L.E.D. [light emitting diode] display reads "FILL" and when keyboard [touchpad] entries are selected, the L.E.D. [light emitting diode] display continues to read “FILL”)...

1. Dryer is not in level position.
2. Broken connection between level switches.
3. Level switches need to be adjusted.
4. Failed keyboard (touchpad) label assembly.
5. Failed microprocessor controller (computer).

M. Microprocessor controller (computer) will only accept certain keyboard (touchpad) entries...

1. Failed keyboard (touchpad) label assembly.
2. Failed microprocessor controller (computer).

N. Microprocessor controller (computer) locks up and L.E.D. (light emitting diode) display reads erroneous messages or only partial segments...

1. Transient power voltage spikes... disconnect the electrical power to the dryer, wait one (1) minute and reestablish power to the dryer. If problem is evident ...
 - a. Failed microprocessor controller (computer).
 - b. Failed keyboard (touchpad) label assembly.

O. Dryer stops during a cycle, microprocessor controller (computer) buzzer (tone) sounds for five (5) seconds, L.E.D. (light emitting diode) display reads “dSFL” for approximately thirty (30) seconds and then returns to “FILL”...

1. Loose connection somewhere between the microprocessor controller (computer) and the microprocessor temperature sensor.

P. Dryer stops during a cycle, microprocessor controller (computer) buzzer (tone) sounds for a few seconds, and then microprocessor controller (computer) L.E.D. (light emitting diode) returns to “FILL”...

1. Loose connection somewhere in the main power circuit to the microprocessor controller (computer).

Q. Microprocessor controller (computer) L.E.D. (light emitting diode) display reads “SEFL”...

1. Rotational sensor circuit failure... fault somewhere in the tumbler (basket) rotation or circuit ...
 - a. Tumbler (basket) not rotating ...
 - 1) Broken tumbler (basket) drive belts.
 - 2) Failure in drive motor circuit.
 - b. Bad rotation sensor.
 - c. Broken wire or connection between rotation sensor and microprocessor controller (computer).
 - d. Failure in rotational sensor circuit or magnet missing or gap too large.

R. Microprocessor controller (computer) L.E.D. (light emitting diode) reads “Hot”...

1. Possible overheating condition...microprocessor controller (computer) has sensed a temperature which has exceeded 220° F.

“Hot” display will not clear until temperature sensed has dropped to 220° F or lower and the microprocessor controller (computer) is manually reset by pressing the “CLEAR/STOP” key.

S. No heat (for STEAM MODELS ONLY)... both microprocessor controller (computer) L.E.D. (light emitting diode) heat indicator dot and the “HEAT” relay output L.E.D. are on...

1. Fault in 225° F hi-heat (limit) switch circuit or thermostat.
2. No (external) compressed air to steam damper...80 PSI required.
3. Failed steam damper 24 VAC pneumatic solenoid valve.
4. Failed steam damper pistons.
5. Steam damper stuck closed.

T. Dryer operates but is taking too long to dry...

1. Exhaust duct work run is too long or is undersized...back pressure **cannot** exceed .3 inches water column (W.C.).
2. Restriction in duct work...check duct from the dryer all the way to the outdoors.
3. Low or inconsistent gas pressure (for GAS MODELS ONLY).
4. Insufficient make-up air.
5. Lint drawer or screen is not being cleaned on a regular basis or often enough.

6. Extractors (washer) not performing properly.
7. Sail switch is fluttering...restriction in exhaust (*for GAS MODELS ONLY*).
8. Failed microprocessor controller (computer)...temperature calibration is inaccurate.
9. Failed microprocessor temperature sensor...calibration is inaccurate.
10. Failed burner hi-limit (*for GAS MODELS ONLY*).
11. Failed 225° F hi-limit (thermostat).
12. Steam damper system is not functioning properly (*for STEAM DRYER ONLY*) ...
 - a. Steam damper sticking closed.
 - b. Leak in pneumatic system.
13. Undersized load, dryer requires a minimum load size of approximately 125 lbs for maximum drying efficiency.

U. Excessive noise and vibration...

1. Dryer is not leveled properly.
2. Impellor (fan and blower) out of balance ...
 - a. Excessive lint build up on impellor (fan and blower)...check air jet.
 - b. Failed impellor (fan and blower).
3. Loose motor mount.
4. Failed idler bearings or tumbler bearings.
5. V-belt(s) either too tight or too loose.
6. Tumbler (basket) drive wheels are worn or are loose.
7. Set screws of tumbler drive shaft bearings are loose.
8. Failed motor bearing.
9. Drive wheel trantorque is loose.

V. Dryer will not tilt...

1. Tilt to unload -- 1-- door...
 - a) Dryer will not tilt unless the front doors are completely open ...
 - 1) No door open signal.
 - 2) Defective proximity switch.
 - 3) No (external) compressed air to pneumatic switches... 80 psi required (11 cf/hr).
2. Tilting to unload -- 2-doors ...
 - a) Dryer will not tilt to unload unless the front doors are closed.
3. Lint drawer is open.

W. Dryer will not level from a tilt position...

1. Lint drawer is open.
2. Defective lint drawer switch.
3. Broken connection between the lint drawer switch and the lint drawer closed relay.
4. Defective pneumatic valve.

SECTION VII

PROCEDURE FOR FUNCTIONAL CHECK OF REPLACEMENT COMPONENTS

1. Microprocessor (computer) Board

- a. Upon completing installation of the replacement microprocessor (computer) board, reestablish power to the dryer.
- b. Start the drying cycle.
- c. Verify that the motor and the heat indicator dots, in the microprocessor (computer) L.E.D. display are on. (Refer to the illustration below.)

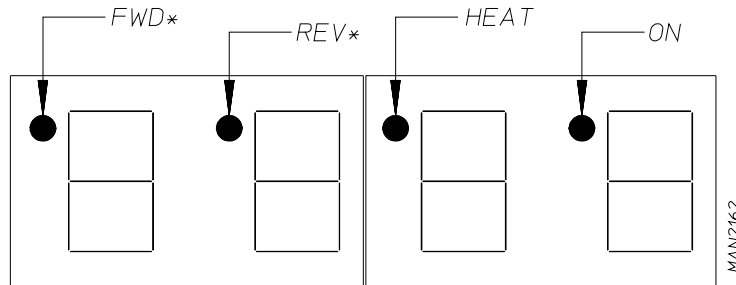

*OPL (NON-COIN) REVERSING MODELS ONLY.

- d. Verify that the motor, heat, and door indicator lights on the back side of the microprocessor (computer) board are lit. (Refer to the illustration below.)

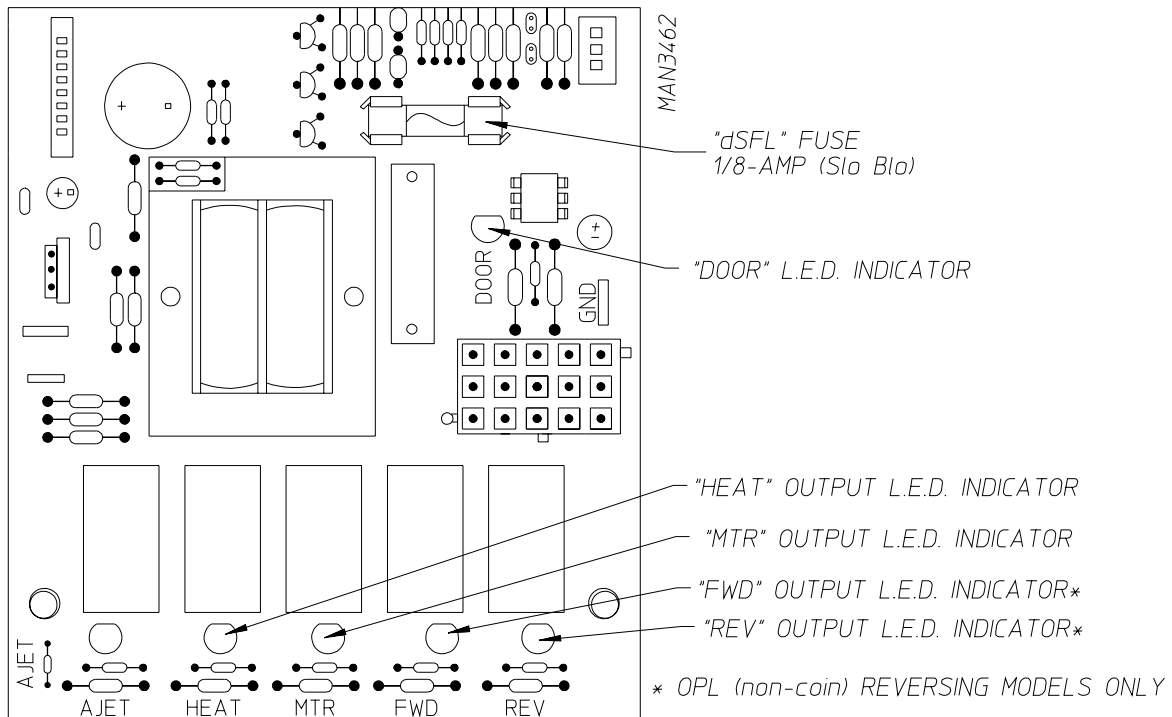

* OPL (non-coin) REVERSING MODELS ONLY

- e. Open main door. The dryer **must stop** and **ALL** indicator lights on the back side of the microprocessor (computer) board **must go out**. (Refer to **illustration** on previous page [page 113].)
- f. Try to restart the dryer with the main door open.
- g. The microprocessor (computer) board's L.E.D. display **must read "DOOR."**
- h. Close the main door and restart the dryer.
- i. Functional check of microprocessor (computer) board is complete.

2. Direct Spark Ignition (DSI) System

- a. Upon completing installation of the replacement Direct Spark Ignition (DSI) module, reestablish power to the dryer.
- b. Start the drying cycle.
- c. The ignition (DSI) module's L.E.D. indicator will light "red" for up to approximately 1.5 seconds (prepurge time).
- d. The module's indicator light will then turn "green." The gas valve will be energized and the ignitor probe will spark for approximately 8 seconds. The burner flame should now be established.
- e. With the burner flame on, remove the flame sensor wire from the FS terminal of the DSI module.
- f. The burner flame **must shut off** and the ignition module **must lock out** with the DSI module's indicator light "red."

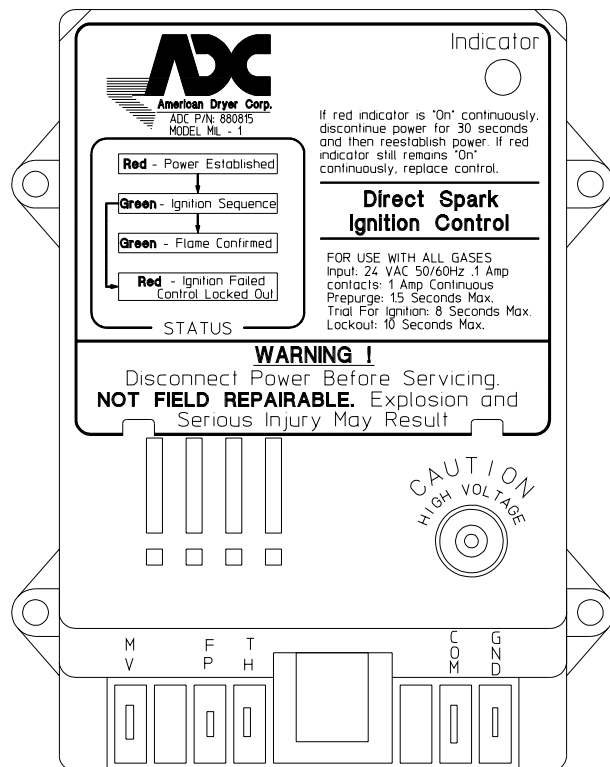

- g. Stop the drying cycle, with the flame sensor wire still removed, restart the drying cycle.
- h. The ignition module **must proceed** through the prepurge, with the indicator light "red," the ignition trial time of approximately 8 seconds, with the indicator light "green," and then proceed to lock out with the indicator light "red."
- i. Functional check of the Direct Spark Ignition (DSI) Module is complete.
 - 1) Replace the flame sensor wire from the FS terminal to the DSI module.

ADC450413 1- 05/11/99-25 2- 01/31/00-5

